

ALLIANT ENGINEERING, INC.

733 S Marquette Ave #700, Minneapolis, MN 55402

Intersection: 80th Street & Blaine Avenue
 Date: 9/19/2024
 Duration: 0600-1900

Site Code: 412
 Ref Pt: N/A
 Page No: 1 of 4

All Vehicles (Cars & Trucks) Printed

Start Time	Blaine Avenue Southbound						80th Street Westbound						Blaine Avenue Northbound						80th Street Eastbound						Int. Veh. Total	Int. Ped/ Bike Total	
	U-Turn	Left	Thru	Right	App. Total	Peds/ Bikes	U-Turn	Left	Thru	Right	App. Total	Peds/ Bikes	U-Turn	Left	Thru	Right	App. Total	Peds/ Bikes	U-Turn	Left	Thru	Right	App. Total	Peds/ Bikes			
6:00	--	--	--	6	6	1	--	--	36	2	38	1	--	2	--	1	3	--	--	2	14	2	18	--	65	2	
6:15	--	3	--	5	8	1	--	1	51	2	54	--	--	1	1	1	3	--	--	2	11	1	14	--	79	1	
6:30	--	3	--	14	17	--	--	1	70	1	72	--	--	5	1	--	6	--	--	4	22	2	28	--	123	--	
6:45	--	5	3	9	17	--	--	3	68	2	73	--	--	3	2	1	6	--	--	--	34	6	40	--	136	--	
Hour Total	--	11	3	34	48	2	--	5	225	7	237	1	--	11	4	3	18	--	--	8	81	11	100	--	403	3	
7:00	--	1	--	10	11	--	--	3	86	3	92	--	--	3	2	2	7	--	--	5	29	9	43	--	153	--	
7:15	--	8	1	11	20	--	--	2	74	2	78	--	--	7	1	1	9	--	--	4	59	18	81	--	188	--	
7:30	--	9	3	17	29	--	--	2	100	5	107	--	--	11	--	2	13	--	--	5	69	48	122	--	271	--	
7:45	--	10	2	8	20	--	--	7	71	4	82	--	--	8	1	4	13	--	--	6	69	92	167	--	282	--	
Hour Total	--	28	6	46	80	--	--	14	331	14	359	--	--	29	4	9	42	--	--	20	226	167	413	--	894	--	
8:00	--	36	4	13	53	--	--	4	78	4	86	--	--	9	--	5	14	--	--	10	102	33	145	--	298	--	
8:15	--	29	2	8	39	2	--	3	120	12	135	--	--	9	5	9	23	2	--	7	104	19	130	--	327	4	
8:30	--	3	3	8	14	1	--	4	73	5	82	1	--	1	--	4	5	--	--	3	35	22	60	--	161	2	
8:45	--	4	3	12	19	--	--	5	58	4	67	--	--	6	2	5	13	2	--	6	40	38	84	--	183	2	
Hour Total	--	72	12	41	125	3	--	16	329	25	370	1	--	25	7	23	55	4	--	26	281	112	419	--	969	8	
9:00	--	4	3	5	12	1	--	7	56	3	66	2	--	15	2	5	22	2	--	9	32	41	82	--	182	5	
9:15	--	6	4	4	14	--	--	14	50	1	65	--	--	11	1	3	15	--	--	7	35	53	95	--	189	--	
9:30	--	3	3	8	14	--	--	9	49	6	64	--	--	13	1	2	16	--	--	8	43	45	96	--	190	--	
9:45	--	1	8	10	19	--	--	7	53	5	65	1	--	24	4	5	33	1	--	2	48	61	111	--	228	2	
Hour Total	--	14	18	27	59	1	--	37	208	15	260	3	--	63	8	15	86	3	--	26	158	200	384	--	789	7	
10:00	--	2	1	4	7	--	--	3	40	2	45	--	--	11	1	5	17	--	--	4	58	20	82	--	151	--	
10:15	--	4	--	7	11	--	--	5	53	4	62	1	--	15	4	4	23	1	--	6	39	21	66	--	162	2	
10:30	--	1	2	11	14	--	--	3	43	6	52	--	--	16	3	7	26	--	--	4	24	21	49	--	141	--	
10:45	--	8	3	4	15	--	--	6	50	2	58	1	--	42	4	6	52	--	--	1	2	49	26	78	--	203	1
Hour Total	--	15	6	26	47	--	--	17	186	14	217	2	--	84	12	22	118	1	--	1	16	170	88	275	--	657	3
11:00	--	6	4	7	17	--	--	9	46	6	61	--	--	27	1	4	32	--	--	4	58	23	85	1	195	1	
11:15	--	8	7	11	26	--	--	5	66	4	75	--	--	19	3	5	27	--	--	8	59	12	79	--	207	--	
11:30	--	6	5	11	22	--	--	7	44	7	58	--	--	24	5	8	37	2	--	7	47	18	72	--	189	2	
11:45	--	1	4	6	11	--	--	8	41	7	56	--	--	37	6	9	52	1	--	8	51	27	86	1	205	2	
Hour Total	--	21	20	35	76	--	--	29	197	24	250	--	--	107	15	26	148	3	--	27	215	80	322	2	796	5	
12:00	--	11	7	5	23	--	--	11	52	9	72	--	--	27	5	11	43	1	--	4	49	30	83	--	221	1	
12:15	--	6	5	7	18	1	--	15	56	3	74	--	--	35	4	6	45	--	--	10	58	17	85	--	222	1	
12:30	--	8	3	13	24	--	--	6	54	7	67	--	--	9	1	7	17	--	--	9	52	13	74	--	182	--	
12:45	--	7	3	8	18	1	--	5	45	7	57	--	--	20	1	2	23	--	--	5	50	15	70	--	168	1	
Hour Total	--	32	18	33	83	2	--	37	207	26	270	--	--	91	11	26	128	1	--	28	209	75	312	--	793	3	
13:00	--	5	2	6	13	--	--	8	46	9	63	--	--	8	2	9	19	1	--	8	52	7	67	--	162	1	
13:15	--	7	2	9	18	1	--	5	48	2	55	--	--	30	2	11	43	1	--	13	43	15	71	--	187	2	
13:30	--	6	2	5	13	--	--	6	62	3	71	1	--	33	2	7	42	1	--	9	60	13	82	--	208	2	
13:45	--	2	3	9	14	--	--	3	48	6	57	--	--	44	3	13	60	--	--	10	51	19	80	--	211	--	
Hour Total	--	20	9	29	58	1	--	22	204	20	246	1	--	115	9	40	164	3	--	40	206	54	300	--	768	5	
14:00	--	--	--	6	6	--	--	8	41	4	53	--	--	40	--	7	47	1	--	13	70	17	100	--	206	1	
14:15	--	8	--	6	14	--	--	1	44	9	54	--	--	11	2	9	22	6	--	1	10	60	7	78	--	168	6
14:30	--	6	1	3	10	1	--	6	48	8	62	--	--	17	2	2	21	--	--	17	65	18	100	--	193	1	
14:45	--	8	6	9	23	--	--	5	55	10	70	1	--	16	8	7	31	--	--	15	80	13	108	--	232	1	
Hour Total	--	22	7	24	53	1	--	20	188	31	239	1	--	84	12	25	121	7	--	1	55	275	55	386	--	799	9
15:00	--	10	2	7	19	--	--	4	43	8	55	--	--	35	--	6	41	--	--	14	102	14	130	--	245	--	
15:15	--	13	5	14	32	--	--	8	89	15	112	1	--	5	1	5	11	1	--	11	116	12	139	--	294	2	
15:30	--	14	5	10	29	--	--	5	126	16	147	1	--	15	9	7	31	--	--	20	102	10	132	--	339	1	
15:45	--	13	7	13	33	--	--	8	70	17	95	1	--	19	2	1	22	2	--	14	113	9	136	--	286	3	
Hour Total	--	50	19	44	113	--	--	25	328	56	409	3	--	74	12	19	105	3	--	59	433	45	537	--	1164	6	
16:00	--	8	1	11	20	1	--	5	97	11	113	1	--	19	2	1	22	2	--	12	113	6	131	--	286	4	
16:15	--	18	2	15	35	1	--	5	81	10	96	1	--	20	2	4	26	1	--	11	126	7	144	--	301	3	
16:30	--	11	--	12	23	--	--	2	113	13	128	--	--	34	--	4	38	--	--	19	115	10	144	--	333	--	
16:45	--	14	2	12	28	--	--	4	78	5	87	--	--	31	6	10	47	--	--	15	99	9	123	--	285	--	
Hour Total	--	51	5	50	106	2	--	16	369	39	424	2	--	104	10	19	133	3	--	57	453	32	542	--	1205	7	
17:00	--	5	1	14	20	--	--	3	83	6	92	--	--	31	3	5	39	1	--	8	75	7	90	--	241	1	
17:15	--	7	--	12	19	--	--	2	93	12	107	--	--	13	1	1	15	1	--	16	94	8	118	--	259	1	
17:30	--																										

ALLIANT ENGINEERING, INC.

733 S Marquette Ave #700, Minneapolis, MN 55402

Intersection: 80th Street & Blaine Avenue
 Date: 9/19/2024
 Duration: 0600-1900

Site Code: 412
 Ref Pt: N/A
 Page No: 2 of 4

All Vehicles (Cars & Trucks) Printed

Start Time	Blaine Avenue Southbound						80th Street Westbound						Blaine Avenue Northbound						80th Street Eastbound						Int. Veh. Total	Int. Ped/Bike Total
	U-Turn	Left	Thru	Right	App. Total	Peds/Bikes	U-Turn	Left	Thru	Right	App. Total	Peds/Bikes	U-Turn	Left	Thru	Right	App. Total	Peds/Bikes	U-Turn	Left	Thru	Right	App. Total	Peds/Bikes		
7:30	--	9	3	17	29	--	--	2	100	5	107	--	--	11	--	2	13	--	--	5	69	48	122	--	271	--
7:45	--	10	2	8	20	--	--	7	71	4	82	--	--	8	1	4	13	--	--	6	69	92	167	--	282	--
8:00	--	36	4	13	53	--	--	4	78	4	86	--	--	9	--	5	14	--	--	10	102	33	145	--	298	--
8:15	--	29	2	8	39	2	--	3	120	12	135	--	--	9	5	9	23	2	--	7	104	19	130	--	327	4
Hour Total	--	84	11	46	141	2	--	16	369	25	410	--	--	37	6	20	63	2	--	28	344	192	564	--	1178	4
% of App.	0.0%	59.6%	7.8%	32.6%			0.0%	3.9%	90.0%	6.1%			0.0%	58.7%	9.5%	31.7%			0.0%	5.0%	61.0%	34.0%				
% of Total	0.0%	7.1%	0.9%	3.9%	12.0%	50.0%	0.0%	1.4%	31.3%	2.1%	34.8%	0.0%	0.0%	3.1%	0.5%	1.7%	5.3%	50.0%	0.0%	2.4%	29.2%	16.3%	47.9%	0.0%		
Cars Total	--	80	11	46	137	2	--	15	365	23	403	--	--	37	6	18	61	1	--	26	332	192	550	--	1151	3
Cars % of Movement	0.0%	95.2%	100%	100%	97.2%	66.7%	0.0%	93.8%	98.9%	92.0%	98.3%	0.0%	0.0%	100%	100%	90.0%	96.8%	33.3%	0.0%	92.9%	96.5%	100%	97.5%	0.0%	97.7%	
Trucks Total	--	4	--	--	4	--	--	1	4	2	7	--	--	--	--	2	2	1	--	2	12	--	14	--	27	1
Trucks % of Movement	0.0%	4.8%	0.0%	0.0%	2.8%	0.0%	0.0%	6.3%	1.1%	8.0%	1.7%	0.0%	0.0%	0.0%	0.0%	10.0%	3.2%	100.0%	0.0%	7.1%	3.5%	0.0%	2.5%	0.0%	2.3%	

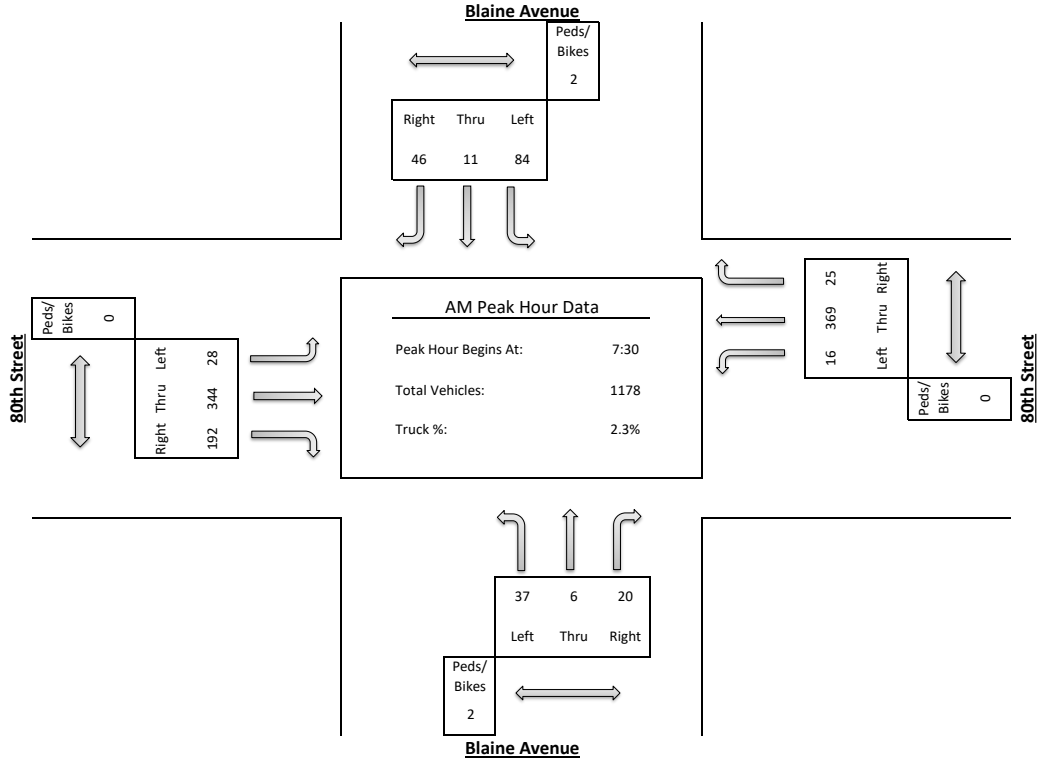

ALLIANT ENGINEERING, INC.

733 S Marquette Ave #700, Minneapolis, MN 55402

Intersection: 80th Street & Blaine Avenue
 Date: 9/19/2024
 Duration: 0600-1900

Site Code: 412
 Ref Pt: N/A
 Page No: 3 of 4

All Vehicles (Cars & Trucks) Printed

Start Time	Blaine Avenue Southbound						80th Street Westbound						Blaine Avenue Northbound						80th Street Eastbound						Int. Veh. Total	Int. Ped/Bike Total
	U-Turn	Left	Thru	Right	App. Total	Peds/Bikes	U-Turn	Left	Thru	Right	App. Total	Peds/Bikes	U-Turn	Left	Thru	Right	App. Total	Peds/Bikes	U-Turn	Left	Thru	Right	App. Total	Peds/Bikes		
11:30	--	6	5	11	22	--	--	7	44	7	58	--	--	24	5	8	37	2	--	7	47	18	72	--	189	2
11:45	--	1	4	6	11	--	--	8	41	7	56	--	--	37	6	9	52	1	--	8	51	27	86	1	205	2
12:00	--	11	7	5	23	--	--	11	52	9	72	--	--	27	5	11	43	1	--	4	49	30	83	--	221	1
12:15	--	6	5	7	18	1	--	15	56	3	74	--	--	35	4	6	45	--	--	10	58	17	85	--	222	1
Hour Total	--	24	21	29	74	1	--	41	193	26	260	--	--	123	20	34	177	4	--	29	205	92	326	1	837	6
% of App.	0.0%	32.4%	28.4%	39.2%			0.0%	15.8%	74.2%	10.0%			0.0%	69.5%	11.3%	19.2%			0.0%	8.9%	62.9%	28.2%				
% of Total	0.0%	2.9%	2.5%	3.5%	8.8%	16.7%	0.0%	4.9%	23.1%	3.1%	31.1%	0.0%	0.0%	14.7%	2.4%	4.1%	21.1%	66.7%	0.0%	3.5%	24.5%	11.0%	38.9%	16.7%		
Cars Total	--	24	21	28	73	--	--	40	190	26	256	--	--	122	20	34	176	3	--	25	199	90	314	--	819	3
Cars % of Movement	0.0%	100%	100%	96.6%	98.6%	0.0%	0.0%	97.6%	98.4%	100%	98.5%	0.0%	0.0%	99.2%	100%	100%	99.4%	100.0%	0.0%	86.2%	97.1%	97.8%	96.3%	0.0%	97.8%	
Trucks Total	--	--	--	1	1	1	--	1	3	--	4	--	--	1	--	--	1	1	--	4	6	2	12	1	18	3
Trucks % of Movement	0.0%	0.0%	0.0%	3.4%	1.4%	33.3%	0.0%	2.4%	1.6%	0.0%	1.5%	0.0%	0.0%	0.8%	0.0%	0.0%	0.6%	33.3%	0.0%	13.8%	2.9%	2.2%	3.7%	33.3%	2.2%	

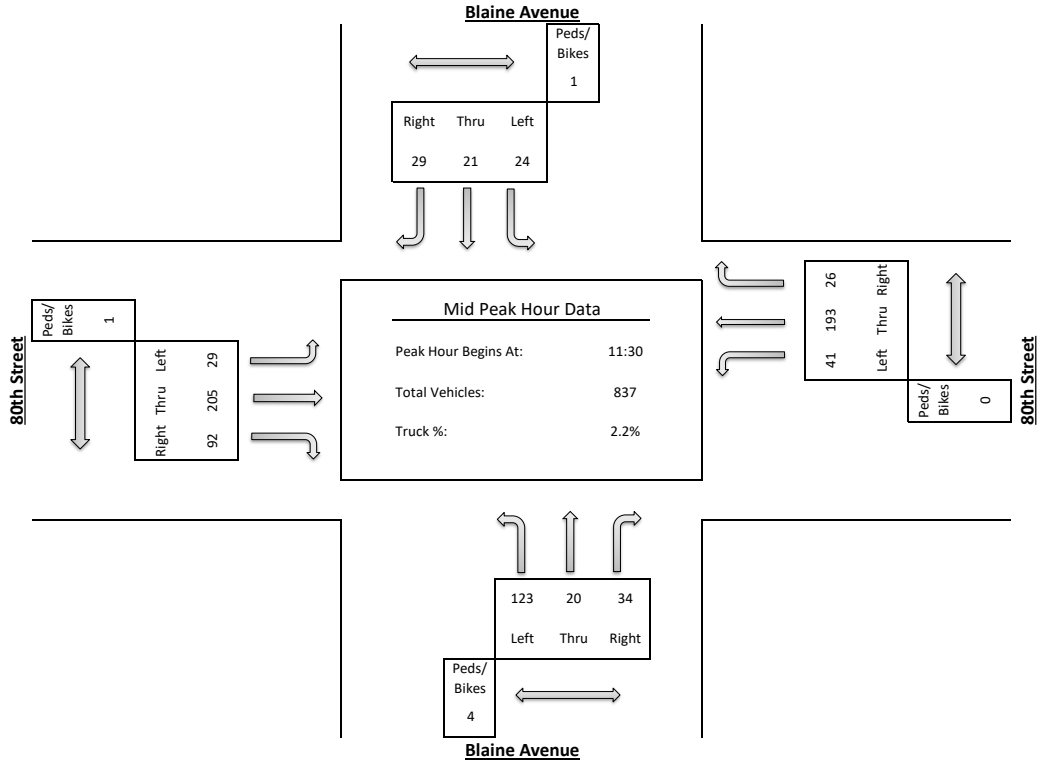

ALLIANT ENGINEERING, INC.

733 S Marquette Ave #700, Minneapolis, MN 55402

Intersection: 80th Street & Blaine Avenue
 Date: 9/19/2024
 Duration: 0600-1900

Site Code: 412
 Ref Pt: N/A
 Page No: 4 of 4

All Vehicles (Cars & Trucks) Printed

Start Time	Blaine Avenue Southbound						80th Street Westbound						Blaine Avenue Northbound						80th Street Eastbound						Int. Veh. Total	Int. Ped/Bike Total
	U-Turn	Left	Thru	Right	App. Total	Peds/Bikes	U-Turn	Left	Thru	Right	App. Total	Peds/Bikes	U-Turn	Left	Thru	Right	App. Total	Peds/Bikes	U-Turn	Left	Thru	Right	App. Total	Peds/Bikes		
15:30	--	14	5	10	29	--	--	5	126	16	147	1	--	15	9	7	31	--	--	20	102	10	132	--	339	1
15:45	--	13	7	13	33	--	--	8	70	17	95	1	--	19	2	1	22	2	--	14	113	9	136	--	286	3
16:00	--	8	1	11	20	1	--	5	97	11	113	1	--	19	2	1	22	2	--	12	113	6	131	--	286	4
16:15	--	18	2	15	35	1	--	5	81	10	96	1	--	20	2	4	26	1	--	11	126	7	144	--	301	3
Hour Total	--	53	15	49	117	2	--	23	374	54	451	4	--	73	15	13	101	5	--	57	454	32	543	--	1212	11
% of App.	0.0%	45.3%	12.8%	41.9%			0.0%	5.1%	82.9%	12.0%			0.0%	72.3%	14.9%	12.9%			0.0%	10.5%	83.6%	5.9%				
% of Total	0.0%	4.4%	1.2%	4.0%	9.7%	18.2%	0.0%	1.9%	30.9%	4.5%	37.2%	36.4%	0.0%	6.0%	1.2%	1.1%	8.3%	45.5%	0.0%	4.7%	37.5%	2.6%	44.8%	0.0%		
Cars Total	--	53	15	47	115	2	--	19	364	51	434	3	--	73	14	11	98	2	--	54	443	32	529	--	1176	7
Cars % of Movement	0.0%	100%	100%	95.9%	98.3%	28.6%	0.0%	82.6%	97.3%	94.4%	96.2%	42.9%	0.0%	100%	93.3%	84.6%	97.0%	28.6%	0.0%	94.7%	97.6%	100%	97.4%	0.0%	97.0%	
Trucks Total	--	--	--	2	2	--	--	4	10	3	17	1	--	--	1	2	3	3	--	3	11	--	14	--	36	4
Trucks % of Movement	0.0%	0.0%	0.0%	4.1%	1.7%	0.0%	0.0%	17.4%	2.7%	5.6%	3.8%	25.0%	0.0%	0.0%	6.7%	15.4%	3.0%	75.0%	0.0%	5.3%	2.4%	0.0%	2.6%	0.0%	3.0%	

