

Short Elliott Hendrickson Inc.

3535 Vadnais Center Drive
St. Paul, MN 55110

"Building a Better World for All of Us"



TRAFFIC DATA

TH 95 (Manning Avenue) & Hudson Rd
Ref.Pt.: 106.800
Data By: Short Elliott Hendrickson, Inc.
TURN MOVEMENT COUNT

File Name : TH 95 (Manning Ave) & Hudson Rd 2019
Site Code : 7c
Start Date : 4/30/2019
Page No : 1

Groups Printed- Vehicles - Trucks

Start Time	Manning Ave Southbound					Hudson Rd Westbound					Manning Ave Northbound					Hudson Rd Eastbound					Int. Total
	Left	Thru	Right	Peds	App. Total	Left	Thru	Right	Peds	App. Total	Left	Thru	Right	Peds	App. Total	Left	Thru	Right	Peds	App. Total	
06:00	10	35	2	0	47	2	4	15	0	21	2	91	0	0	93	4	1	2	0	7	168
06:15	9	73	8	0	90	2	5	23	0	30	1	90	3	0	94	6	3	4	0	13	227
06:30	23	108	7	0	138	3	3	20	0	26	5	129	6	0	140	11	3	2	0	16	320
06:45	28	95	9	0	132	5	10	30	0	45	3	133	7	0	143	17	5	2	0	24	344
Total	70	311	26	0	407	12	22	88	0	122	11	443	16	0	470	38	12	10	0	60	1059
07:00	18	102	12	0	132	11	10	24	0	45	6	157	3	0	166	23	1	2	0	26	369
07:15	7	145	18	0	170	14	9	32	0	55	7	172	2	0	181	34	5	3	0	42	448
07:30	16	133	33	0	182	5	8	36	0	49	8	191	8	0	207	39	6	3	0	48	486
07:45	23	137	34	0	194	5	19	13	0	37	5	143	6	0	154	23	2	5	0	30	415
Total	64	517	97	0	678	35	46	105	0	186	26	663	19	0	708	119	14	13	0	146	1718
08:00	13	72	16	0	101	8	7	19	0	34	2	124	4	0	130	18	8	3	0	29	294
08:15	10	83	15	0	108	6	10	21	0	37	1	120	12	0	133	18	12	4	0	34	312
08:30	11	77	19	0	107	14	15	27	0	56	8	124	3	0	135	14	6	5	0	25	323
08:45	16	77	14	0	107	2	11	15	0	28	1	104	5	0	110	12	10	4	0	26	271
Total	50	309	64	0	423	30	43	82	0	155	12	472	24	0	508	62	36	16	0	114	1200
09:00	9	73	14	0	96	3	8	17	0	28	6	94	12	0	112	17	14	7	0	38	274
09:15	19	53	20	1	93	9	12	14	0	35	4	83	8	0	95	14	6	4	0	24	247
09:30	15	57	20	0	92	4	11	13	0	28	1	79	5	0	85	14	4	5	0	23	228
09:45	18	69	19	0	106	7	11	16	0	34	3	67	2	0	72	15	8	5	0	28	240
Total	61	252	73	1	387	23	42	60	0	125	14	323	27	0	364	60	32	21	0	113	989
10:00	11	61	17	0	89	1	5	12	0	18	4	60	2	0	66	7	2	3	0	12	185
10:15	15	43	16	0	74	5	7	18	0	30	4	64	4	0	72	7	3	7	0	17	193
10:30	7	57	10	0	74	1	8	12	0	21	2	70	0	0	72	14	6	0	0	20	187
10:45	10	53	17	0	80	2	7	21	0	30	6	59	2	0	67	11	9	7	0	27	204
Total	43	214	60	0	317	9	27	63	0	99	16	253	8	0	277	39	20	17	0	76	769
11:00	10	42	15	0	67	3	7	18	0	28	10	56	4	0	70	19	6	3	0	28	193
11:15	18	60	15	0	93	5	6	10	0	21	7	64	2	0	73	9	5	1	0	15	202
11:30	12	76	24	0	112	1	2	14	0	17	5	57	5	0	67	13	10	1	0	24	220
11:45	14	45	17	0	76	2	11	15	0	28	10	56	8	0	74	20	12	3	0	35	213
Total	54	223	71	0	348	11	26	57	0	94	32	233	19	0	284	61	33	8	0	102	828
12:00	15	54	17	0	86	6	19	17	0	42	8	75	4	0	87	13	14	4	0	31	246
12:15	19	65	17	0	101	3	14	15	0	32	5	55	6	0	66	11	12	3	0	26	225
12:30	10	49	14	0	73	5	9	20	0	34	4	70	3	0	77	16	15	3	0	34	218
12:45	17	60	14	0	91	4	5	15	0	24	6	63	2	0	71	22	12	6	0	40	226
Total	61	228	62	0	351	18	47	67	0	132	23	263	15	0	301	62	53	16	0	131	915
13:00	16	59	12	0	87	3	2	12	0	17	1	37	1	0	39	15	13	7	0	35	178
13:15	16	61	12	0	89	2	7	20	0	29	3	56	1	0	60	16	8	4	0	28	206
13:30	19	58	20	0	97	2	6	12	0	20	8	70	1	0	79	17	14	9	0	40	236
13:45	16	68	15	0	99	0	5	10	0	15	4	70	6	0	80	21	13	2	0	36	230
Total	67	246	59	0	372	7	20	54	0	81	16	233	9	0	258	69	48	22	0	139	850

Short Elliott Hendrickson Inc.

3535 Vadnais Center Drive
St. Paul, MN 55110

"Building a Better World for All of Us"



TRAFFIC DATA

TH 95 (Manning Avenue) & Hudson Rd
Ref.Pt.: 106.800
Data By: Short Elliott Hendrickson, Inc.
TURN MOVEMENT COUNT

File Name : TH 95 (Manning Ave) & Hudson Rd 2019
Site Code : 7c
Start Date : 4/30/2019
Page No : 2

Groups Printed- Vehicles - Trucks

Start Time	Manning Ave Southbound					Hudson Rd Westbound					Manning Ave Northbound					Hudson Rd Eastbound					Int. Total
	Left	Thru	Right	Peds	App. Total	Left	Thru	Right	Peds	App. Total	Left	Thru	Right	Peds	App. Total	Left	Thru	Right	Peds	App. Total	
14:00	17	77	19	0	113	4	5	14	0	23	4	59	2	0	65	20	19	3	0	42	243
14:15	14	102	27	0	143	4	6	17	0	27	6	65	5	0	76	29	17	8	0	54	300
14:30	19	100	33	0	152	9	6	37	1	53	3	67	3	0	73	12	10	10	0	32	310
14:45	26	107	32	0	165	4	4	12	0	20	5	70	4	0	79	24	10	6	0	40	304
Total	76	386	111	0	573	21	21	80	1	123	18	261	14	0	293	85	56	27	0	168	1157
15:00	23	100	23	0	146	5	4	15	0	24	6	83	8	0	97	22	14	6	0	42	309
15:15	27	97	23	0	147	3	9	16	0	28	2	90	8	0	100	35	21	8	0	64	339
15:30	29	108	20	0	157	9	22	35	0	66	5	119	10	0	134	25	18	9	0	52	409
15:45	17	102	26	0	145	1	7	21	0	29	9	119	9	0	137	24	16	8	0	48	359
Total	96	407	92	0	595	18	42	87	0	147	22	411	35	0	468	106	69	31	0	206	1416
16:00	21	106	29	0	156	9	15	29	0	53	5	126	3	0	134	30	19	5	0	54	397
16:15	16	152	20	0	188	10	26	15	0	51	6	112	7	0	125	32	20	7	0	59	423
16:30	18	130	21	0	169	3	16	21	0	40	5	128	3	0	136	33	19	8	0	60	405
16:45	23	141	16	0	180	7	6	13	0	26	4	149	8	0	161	42	28	9	0	79	446
Total	78	529	86	0	693	29	63	78	0	170	20	515	21	0	556	137	86	29	0	252	1671
17:00	34	131	29	0	194	12	14	12	0	38	7	126	5	0	138	36	30	12	0	78	448
17:15	27	161	22	0	210	3	5	7	0	15	4	99	12	0	115	35	23	10	0	68	408
17:30	23	146	22	0	191	7	8	11	0	26	4	127	7	0	138	37	28	7	0	72	427
17:45	24	117	21	0	162	5	6	15	0	26	3	88	9	0	100	30	28	10	0	68	356
Total	108	555	94	0	757	27	33	45	0	105	18	440	33	0	491	138	109	39	0	286	1639
18:00	27	88	26	0	141	6	7	16	0	29	1	91	7	0	99	40	18	8	0	66	335
18:15	23	103	21	0	147	4	12	14	0	30	10	92	2	0	104	21	22	1	0	44	325
18:30	25	91	17	0	133	6	7	12	0	25	4	88	4	0	96	31	19	6	0	56	310
18:45	15	69	17	0	101	1	12	10	0	23	5	69	8	0	82	26	6	10	0	42	248
Total	90	351	81	0	522	17	38	52	0	107	20	340	21	0	381	118	65	25	0	208	1218
Grand Total	918	4528	976	1	6423	257	470	918	1	1646	248	4850	261	0	5359	1094	633	274	0	2001	15429
Apprch %	14.3	70.5	15.2	0		15.6	28.6	55.8	0.1		4.6	90.5	4.9	0		54.7	31.6	13.7	0		
Total %	5.9	29.3	6.3	0	41.6	1.7	3	5.9	0	10.7	1.6	31.4	1.7	0	34.7	7.1	4.1	1.8	0	13	
Vehicles	792	4393									4697				1073						14706
% Vehicles	86.3	97	97.3	0	95.5	86.8	97	83.6	0	87.8	96	96.8	92.7	0	96.6	98.1	95.6	98.5	0	97.4	95.3
Trucks	126	135	26	1	288	34	14	151	1	200	10	153	19	0	182	21	28	4	0	53	723
% Trucks	13.7	3	2.7	100	4.5	13.2	3	16.4	100	12.2	4	3.2	7.3	0	3.4	1.9	4.4	1.5	0	2.6	4.7

Short Elliott Hendrickson Inc.

3535 Vadnais Center Drive
St. Paul, MN 55110

"Building a Better World for All of Us"



TRAFFIC DATA

TH 95 (Manning Avenue) & Hudson Rd
Ref.Pt.: 106.800
Data By: Short Elliott Hendrickson, Inc.
TURN MOVEMENT COUNT

File Name : TH 95 (Manning Ave) & Hudson Rd 2019
Site Code : 7c
Start Date : 4/30/2019
Page No : 3

Start Time	Manning Ave Southbound					Hudson Rd Westbound					Manning Ave Northbound					Hudson Rd Eastbound					Int. Total
	Left	Thru	Right	Peds	App. Total	Left	Thru	Right	Peds	App. Total	Left	Thru	Right	Peds	App. Total	Left	Thru	Right	Peds	App. Total	
Peak Hour Analysis From 06:00 to 08:45 - Peak 1 of 1 Peak Hour for Entire Intersection Begins at 07:00																					
07:00	18	102	12	0	132	11	10	24	0	45	6	157	3	0	166	23	1	2	0	26	369
07:15	7	145	18	0	170	14	9	32	0	55	7	172	2	0	181	34	5	3	0	42	448
07:30	16	133	33	0	182	5	8	36	0	49	8	191	8	0	207	39	6	3	0	48	486
07:45	23	137	34	0	194	5	19	13	0	37	5	143	6	0	154	23	2	5	0	30	415
Total Volume	64	517	97	0	678	35	46	105	0	186	26	663	19	0	708	119	14	13	0	146	1718
% App. Total	9.4	76.3	14.3	0		18.8	24.7	56.5	0		3.7	93.6	2.7	0		81.5	9.6	8.9	0		
PHF	.696	.891	.713	.000	.874	.625	.605	.729	.000	.845	.813	.868	.594	.000	.855	.763	.583	.650	.000	.760	.884

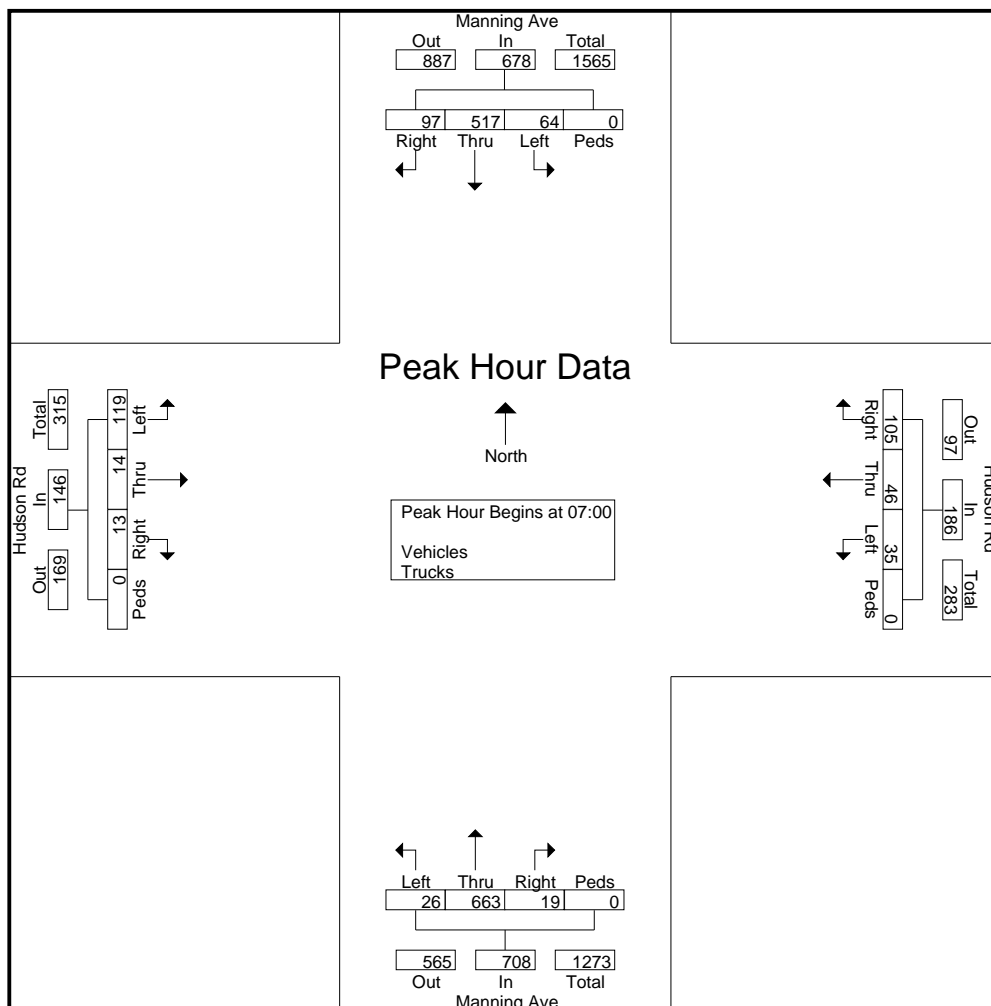

Short Elliott Hendrickson Inc.

3535 Vadnais Center Drive
St. Paul, MN 55110

"Building a Better World for All of Us"



TRAFFIC DATA

TH 95 (Manning Avenue) & Hudson Rd
Ref.Pt.: 106.800
Data By: Short Elliott Hendrickson, Inc.
TURN MOVEMENT COUNT

File Name : TH 95 (Manning Ave) & Hudson Rd 2019
Site Code : 7c
Start Date : 4/30/2019
Page No : 4

Start Time	Manning Ave Southbound					Hudson Rd Westbound					Manning Ave Northbound					Hudson Rd Eastbound					Int. Total
	Left	Thru	Right	Peds	App. Total	Left	Thru	Right	Peds	App. Total	Left	Thru	Right	Peds	App. Total	Left	Thru	Right	Peds	App. Total	
Peak Hour Analysis From 11:00 to 12:45 - Peak 1 of 1 Peak Hour for Entire Intersection Begins at 12:00																					
12:00	15	54	17	0	86	6	19	17	0	42	8	75	4	0	87	13	14	4	0	31	246
12:15	19	65	17	0	101	3	14	15	0	32	5	55	6	0	66	11	12	3	0	26	225
12:30	10	49	14	0	73	5	9	20	0	34	4	70	3	0	77	16	15	3	0	34	218
12:45	17	60	14	0	91	4	5	15	0	24	6	63	2	0	71	22	12	6	0	40	226
Total Volume	61	228	62	0	351	18	47	67	0	132	23	263	15	0	301	62	53	16	0	131	915
% App. Total	17.4	65	17.7	0		13.6	35.6	50.8	0		7.6	87.4	5	0		47.3	40.5	12.2	0		
PHF	.803	.877	.912	.000	.869	.750	.618	.838	.000	.786	.719	.877	.625	.000	.865	.705	.883	.667	.000	.819	.930

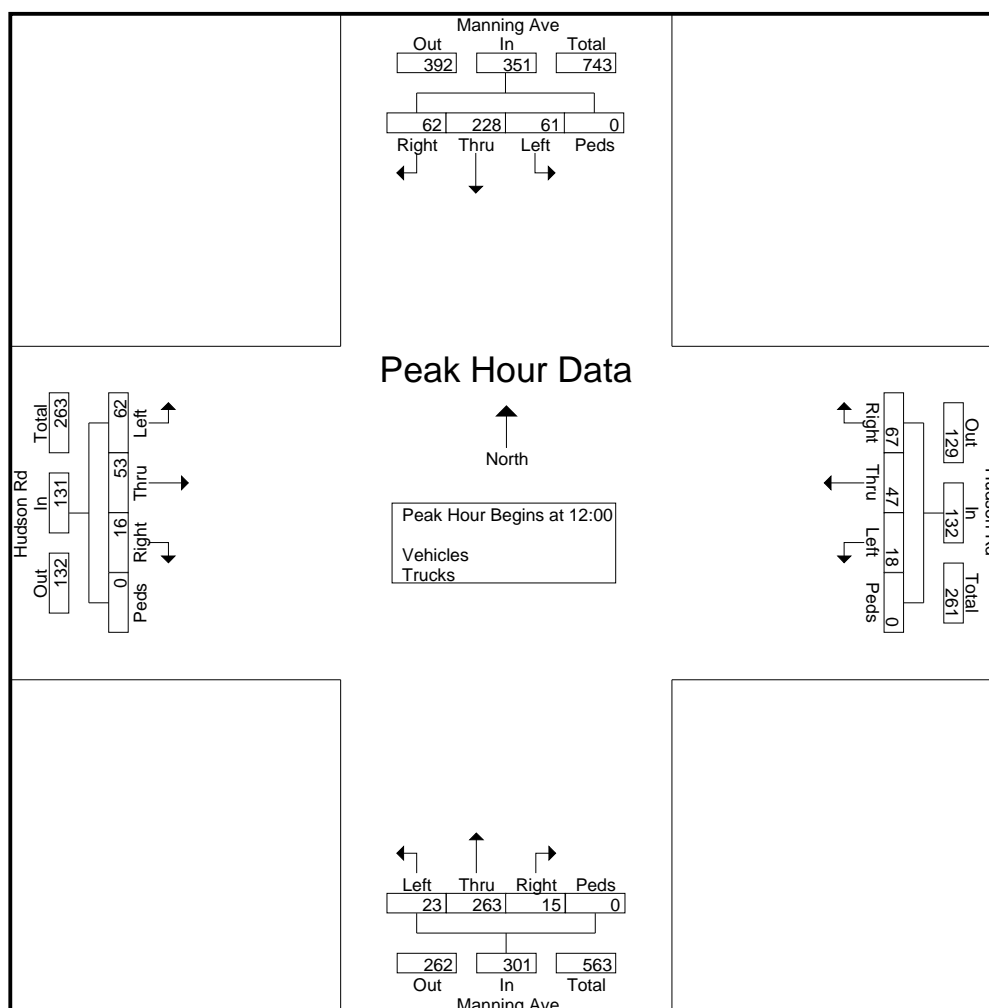

Short Elliott Hendrickson Inc.

3535 Vadnais Center Drive
St. Paul, MN 55110

"Building a Better World for All of Us"



TRAFFIC DATA

TH 95 (Manning Avenue) & Hudson Rd
Ref.Pt.: 106.800
Data By: Short Elliott Hendrickson, Inc.
TURN MOVEMENT COUNT

File Name : TH 95 (Manning Ave) & Hudson Rd 2019
Site Code : 7c
Start Date : 4/30/2019
Page No : 5

Start Time	Manning Ave Southbound					Hudson Rd Westbound					Manning Ave Northbound					Hudson Rd Eastbound					Int. Total
	Left	Thru	Right	Peds	App. Total	Left	Thru	Right	Peds	App. Total	Left	Thru	Right	Peds	App. Total	Left	Thru	Right	Peds	App. Total	
Peak Hour Analysis From 15:00 to 17:45 - Peak 1 of 1 Peak Hour for Entire Intersection Begins at 16:45																					
16:45	23	141	16	0	180	7	6	13	0	26	4	149	8	0	161	42	28	9	0	79	446
17:00	34	131	29	0	194	12	14	12	0	38	7	126	5	0	138	36	30	12	0	78	448
17:15	27	161	22	0	210	3	5	7	0	15	4	99	12	0	115	35	23	10	0	68	408
17:30	23	146	22	0	191	7	8	11	0	26	4	127	7	0	138	37	28	7	0	72	427
Total Volume	107	579	89	0	775	29	33	43	0	105	19	501	32	0	552	150	109	38	0	297	1729
% App. Total	13.8	74.7	11.5	0		27.6	31.4	41	0		3.4	90.8	5.8	0		50.5	36.7	12.8	0		
PHF	.787	.899	.767	.000	.923	.604	.589	.827	.000	.691	.679	.841	.667	.000	.857	.893	.908	.792	.000	.940	.965

