

TRAFFIC DATA INC.

3268 Xenwood Ave S
St Louis Park, MN 55416

TH-13 at CSAH-21 / Eagle Creek Ave.

Ref.Pt.: 085.265 PRIOR LAKE

Data by: Traffic Data Inc

TURN MOVEMENT COUNT

File Name : TH-13 at CSAH-21 Eagle Creek Ave 2009

Site Code : 00182913

Start Date : 4/28/2009

Page No : 1

Groups Printed- Unshifted

Start Time	TH-13 Southbound				CSAH-21 / Eagle Creek Ave Westbound				TH-13 Northbound				CSAH-21 / Eagle Creek Ave Eastbound				Int. Total
	Left	Thru	Right	Peds	Left	Thru	Right	Peds	Left	Thru	Right	Peds	Left	Thru	Right	Peds	
06:00	6	12	6	0	6	30	6	0	6	61	16	0	4	22	2	0	177
06:15	5	16	3	0	11	46	11	0	10	92	17	0	2	39	1	0	253
06:30	10	13	8	0	12	84	9	0	18	129	22	1	9	36	3	0	354
06:45	7	19	8	0	9	79	10	0	17	172	22	0	13	38	6	0	400
Total	28	60	25	0	38	239	36	0	51	454	77	1	28	135	12	0	1184
07:00	9	48	17	0	21	87	14	1	21	114	16	1	13	53	7	0	422
07:15	4	41	17	0	18	107	9	0	16	134	20	1	9	66	8	0	450
07:30	7	47	15	0	22	144	14	0	19	124	13	1	26	54	2	0	488
07:45	9	49	10	1	16	109	12	0	28	124	16	0	14	42	8	0	438
Total	29	185	59	1	77	447	49	1	84	496	65	3	62	215	25	0	1798
08:00	13	45	15	0	16	77	8	0	18	85	13	0	10	42	7	0	349
08:15	7	39	18	0	8	77	12	0	19	103	15	0	19	47	8	0	372
08:30	8	34	12	0	9	66	12	0	22	90	14	0	23	37	3	0	330
08:45	10	58	19	1	25	73	12	1	23	92	14	0	26	41	5	0	400
Total	38	176	64	1	58	293	44	1	82	370	56	0	78	167	23	0	1451
*** BREAK ***																	
11:00	18	65	15	0	15	31	12	0	13	73	15	1	15	30	15	0	318
11:15	11	75	16	0	8	34	16	0	23	71	9	0	18	40	18	0	339
11:30	16	81	12	0	14	39	9	0	17	81	21	0	12	33	12	0	347
11:45	5	84	14	0	12	42	3	0	20	73	6	4	19	33	6	0	321
Total	50	305	57	0	49	146	40	0	73	298	51	5	64	136	51	0	1325
12:00	11	93	21	0	22	34	6	0	17	86	9	2	17	50	11	0	379
12:15	12	66	20	0	21	43	15	1	21	83	11	0	25	38	12	0	368
12:30	11	87	13	1	16	39	12	0	18	80	11	0	19	34	12	0	353
12:45	18	88	22	1	15	46	11	0	22	55	9	0	13	33	18	0	351
Total	52	334	76	2	74	162	44	1	78	304	40	2	74	155	53	0	1451
*** BREAK ***																	
15:00	13	95	21	1	38	58	15	0	16	72	9	0	20	60	14	0	432
15:15	10	156	31	0	31	51	7	0	23	70	10	0	14	80	14	0	497
15:30	16	144	30	0	45	76	14	0	18	73	11	0	20	68	15	0	530
15:45	18	129	22	0	49	60	12	1	17	89	19	2	22	102	21	0	563
Total	57	524	104	1	163	245	48	1	74	304	49	2	76	310	64	0	2022
16:00	16	137	23	4	40	79	9	0	23	84	18	0	20	99	15	0	567
16:15	15	157	21	3	57	68	15	0	26	104	19	1	16	91	10	0	603
16:30	19	134	27	5	35	77	14	0	26	76	11	1	29	99	12	0	565
16:45	17	152	15	1	34	74	10	2	28	96	12	4	25	111	15	1	597
Total	67	580	86	13	166	298	48	2	103	360	60	6	90	400	52	1	2332
17:00	13	140	22	1	48	82	13	1	30	76	18	2	23	113	21	0	603
17:15	18	159	21	0	45	86	8	0	27	97	13	0	20	119	11	2	626
17:30	19	130	19	0	47	85	20	0	30	74	14	2	23	94	19	0	576
17:45	16	172	29	0	41	78	17	0	35	100	16	0	20	66	23	0	613
Total	66	601	91	1	181	331	58	1	122	347	61	4	86	392	74	2	2418
Grand Total	387	2765	562	19	806	2161	367	7	667	2933	459	23	558	1910	354	3	13981
Apprch %	10.4	74.1	15.1	0.5	24.1	64.7	11	0.2	16.3	71.9	11.2	0.6	19.8	67.6	12.5	0.1	
Total %	2.8	19.8	4	0.1	5.8	15.5	2.6	0.1	4.8	21	3.3	0.2	4	13.7	2.5	0	

TRAFFIC DATA INC.

3268 Xenwood Ave S
St Louis Park, MN 55416

TH-13 at CSAH-21 / Eagle Creek Ave.
Ref.Pt.: 085.265 PRIOR LAKE
Data by: Traffic Data Inc
TURN MOVEMENT COUNT

File Name : TH-13 at CSAH-21 Eagle Creek Ave 2009
Site Code : 00182913
Start Date : 4/28/2009
Page No : 2

Start Time	TH-13 Southbound					CSAH-21 / Eagle Creek Ave Westbound					TH-13 Northbound					CSAH-21 / Eagle Creek Ave Eastbound					Int. Total
	Left	Thru	Right	Peds	App. Total	Left	Thru	Right	Peds	App. Total	Left	Thru	Right	Peds	App. Total	Left	Thru	Right	Peds	App. Total	
Peak Hour Analysis From 06:00 to 08:45 - Peak 1 of 1																					
Peak Hour for Entire Intersection Begins at 07:00																					
07:00	9	48	17	0	74	21	87	14	1	123	21	114	16	1	152	13	53	7	0	73	422
07:15	4	41	17	0	62	18	107	9	0	134	16	134	20	1	171	9	66	8	0	83	450
07:30	7	47	15	0	69	22	144	14	0	180	19	124	13	1	157	26	54	2	0	82	488
07:45	9	49	10	1	69	16	109	12	0	137	28	124	16	0	168	14	42	8	0	64	438
Total Volume	29	185	59	1	274	77	447	49	1	574	84	496	65	3	648	62	215	25	0	302	1798
% App. Total	10.6	67.5	21.5	0.4		13.4	77.9	8.5	0.2		13	76.5	10	0.5		20.5	71.2	8.3	0		
PHF	.806	.944	.868	.250	.926	.875	.776	.875	.250	.797	.750	.925	.813	.750	.947	.596	.814	.781	.000	.910	.921

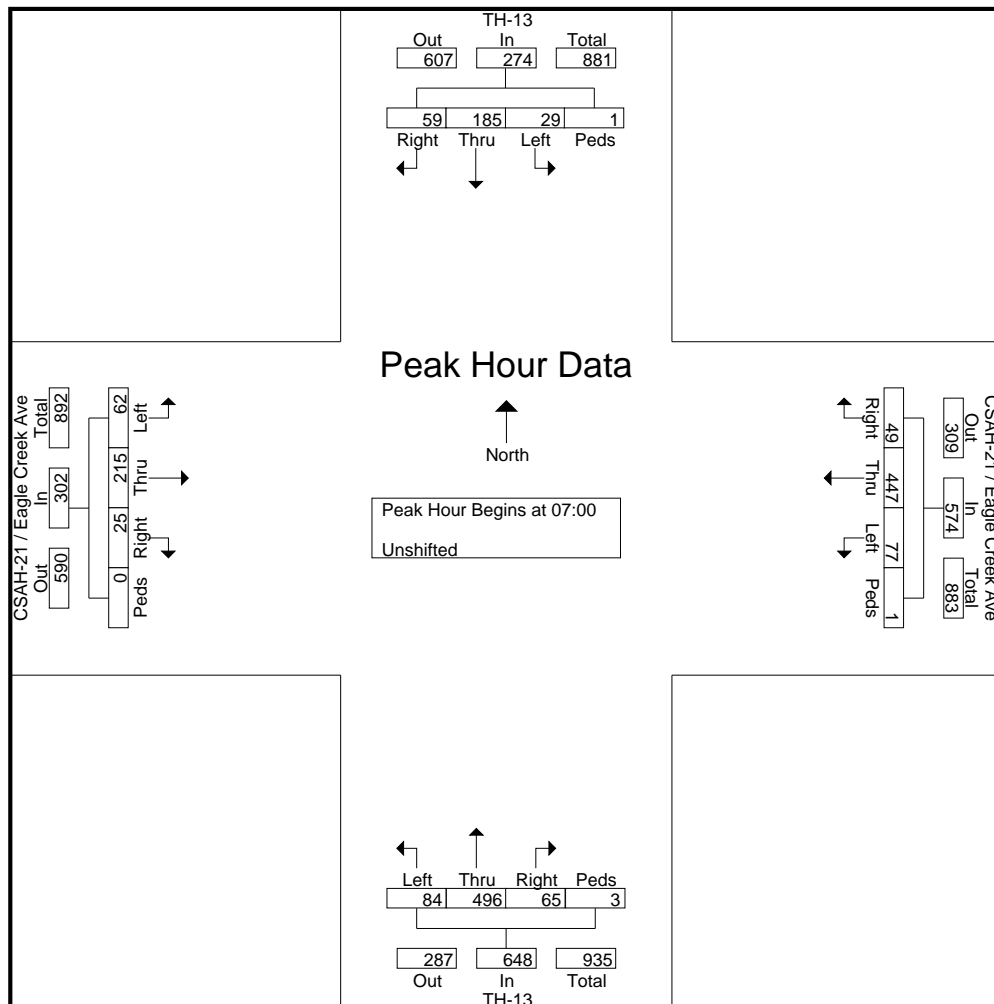

TRAFFIC DATA INC.

3268 Xenwood Ave S
St Louis Park, MN 55416

TH-13 at CSAH-21 / Eagle Creek Ave.
Ref.Pt.: 085.265 PRIOR LAKE
Data by: Traffic Data Inc
TURN MOVEMENT COUNT

File Name : TH-13 at CSAH-21 Eagle Creek Ave 2009
Site Code : 00182913
Start Date : 4/28/2009
Page No : 3

Start Time	TH-13 Southbound					CSAH-21 / Eagle Creek Ave Westbound					TH-13 Northbound					CSAH-21 / Eagle Creek Ave Eastbound					Int. Total
	Left	Thru	Right	Peds	App. Total	Left	Thru	Right	Peds	App. Total	Left	Thru	Right	Peds	App. Total	Left	Thru	Right	Peds	App. Total	
Peak Hour Analysis From 15:00 to 17:45 - Peak 1 of 1																					
Peak Hour for Entire Intersection Begins at 17:00																					
17:00	13	140	22	1	176	48	82	13	1	144	30	76	18	2	126	23	113	21	0	157	603
17:15	18	159	21	0	198	45	86	8	0	139	27	97	13	0	137	20	119	11	2	152	626
17:30	19	130	19	0	168	47	85	20	0	152	30	74	14	2	120	23	94	19	0	136	576
17:45	16	172	29	0	217	41	78	17	0	136	35	100	16	0	151	20	66	23	0	109	613
Total Volume	66	601	91	1	759	181	331	58	1	571	122	347	61	4	534	86	392	74	2	554	2418
% App. Total	8.7	79.2	12	0.1		31.7	58	10.2	0.2		22.8	65	11.4	0.7		15.5	70.8	13.4	0.4		
PHF	.868	.874	.784	.250	.874	.943	.962	.725	.250	.939	.871	.868	.847	.500	.884	.935	.824	.804	.250	.882	.966

