



# MINNESOTA DEPT OF TRANSPORTATION

## TRAFFIC DATA COLLECTION - METRO

TH-25 at Aspen Rd/Commerce Drive  
 Ref.Pt.: 000.038  
 JAMAR # 632 CP  
 TURN MOVEMENT COUNT

File Name : TH-25 at Commerce Dr- Aspen Rd 2010  
 Site Code : 00000000  
 Start Date : 3/18/2010  
 Page No : 1

### Groups Printed- Cars & Trucks

Start Time	Aspen Rd Southbound				TH-25 / E Main St. Westbound				Commerce Drive Northbound				TH-25 / E Main St. Eastbound				Int. Total
	Left	Thru	Right	Peds	Left	Thru	Right	Peds	Left	Thru	Right	Peds	Left	Thru	Right	Peds	
06:00	13	0	0	0	1	18	3	0	0	0	5	0	7	44	0	0	91
06:15	11	1	0	0	1	20	8	0	1	4	8	0	12	48	1	0	115
06:30	24	0	1	0	3	30	8	0	0	2	7	0	9	60	0	0	144
06:45	15	0	0	0	3	35	10	0	0	0	9	0	16	59	1	0	148
Total	63	1	1	0	8	103	29	0	1	6	29	0	44	211	2	0	498
07:00	22	0	2	0	2	35	10	0	0	2	13	0	12	82	0	0	180
07:15	18	1	3	0	8	70	14	0	0	1	9	0	14	78	4	0	220
07:30	15	1	3	0	10	57	17	0	0	1	9	3	13	86	1	0	216
07:45	19	0	2	0	13	83	15	1	1	0	21	0	8	76	4	0	243
Total	74	2	10	0	33	245	56	1	1	4	52	3	47	322	9	0	859
08:00	11	0	1	0	12	99	10	0	2	1	20	0	13	70	1	0	240
08:15	23	1	1	0	15	89	6	0	0	2	34	0	19	90	3	0	283
08:30	23	3	2	0	5	50	12	0	4	6	29	0	17	75	5	0	231
08:45	20	2	2	0	5	58	5	0	0	3	15	0	12	59	2	0	183
Total	77	6	6	0	37	296	33	0	6	12	98	0	61	294	11	0	937
*** BREAK ***																	
15:00	18	2	1	0	11	63	17	0	3	0	15	0	11	62	2	0	205
15:15	12	1	1	0	10	73	21	0	3	1	32	0	20	100	4	0	278
15:30	9	0	3	0	11	104	14	2	1	1	20	0	10	92	1	0	268
15:45	11	0	4	0	12	93	13	0	2	3	18	0	14	87	2	0	259
Total	50	3	9	0	44	333	65	2	9	5	85	0	55	341	9	0	1010
16:00	14	2	4	0	7	106	11	1	6	4	29	0	18	88	3	0	293
16:15	11	1	5	0	7	91	15	0	2	5	13	0	16	103	2	0	271
16:30	12	1	2	0	10	100	20	1	1	5	8	1	13	109	3	0	286
16:45	17	3	4	0	7	127	22	0	2	3	10	0	23	80	1	0	299
Total	54	7	15	0	31	424	68	2	11	17	60	1	70	380	9	0	1149
17:00	17	1	2	0	11	95	19	0	4	4	18	0	23	98	0	0	292
17:15	14	0	3	0	9	90	24	0	2	1	10	0	9	69	1	0	232
17:30	19	2	3	0	11	102	33	1	3	2	12	0	21	89	6	0	304
17:45	11	1	2	0	8	89	17	1	1	0	11	0	12	48	3	0	204
Total	61	4	10	0	39	376	93	2	10	7	51	0	65	304	10	0	1032
Grand Total	379	23	51	0	192	1777	344	7	38	51	375	4	342	1852	50	0	5485
Apprch %	83.7	5.1	11.3	0	8.3	76.6	14.8	0.3	8.1	10.9	80.1	0.9	15.2	82.5	2.2	0	
Total %	6.9	0.4	0.9	0	3.5	32.4	6.3	0.1	0.7	0.9	6.8	0.1	6.2	33.8	0.9	0	



# MINNESOTA DEPT OF TRANSPORTATION

## TRAFFIC DATA COLLECTION - METRO

TH-25 at Aspen Rd/Commerce Drive  
 Ref.Pt.: 000.038  
 JAMAR # 632 CP  
 TURN MOVEMENT COUNT

File Name : TH-25 at Commerce Dr- Aspen Rd 2010  
 Site Code : 00000000  
 Start Date : 3/18/2010  
 Page No : 2

Start Time	Aspen Rd Southbound					TH-25 / E Main St. Westbound					Commerce Drive Northbound					TH-25 / E Main St. Eastbound					Int. Total
	Left	Thru	Right	Peds	App. Total	Left	Thru	Right	Peds	App. Total	Left	Thru	Right	Peds	App. Total	Left	Thru	Right	Peds	App. Total	
Peak Hour Analysis From 06:00 to 08:45 - Peak 1 of 1																					
Peak Hour for Entire Intersection Begins at 07:45																					
07:45	19	0	2	0	21	13	83	15	1	112	1	0	21	0	22	8	76	4	0	88	243
08:00	11	0	1	0	12	12	99	10	0	121	2	1	20	0	23	13	70	1	0	84	240
08:15	23	1	1	0	25	15	89	6	0	110	0	2	34	0	36	19	90	3	0	112	283
08:30	23	3	2	0	28	5	50	12	0	67	4	6	29	0	39	17	75	5	0	97	231
Total Volume	76	4	6	0	86	45	321	43	1	410	7	9	104	0	120	57	311	13	0	381	997
% App. Total	88.4	4.7	7	0		11	78.3	10.5	0.2		5.8	7.5	86.7	0		15	81.6	3.4	0		
PHF	.826	.333	.750	.000	.768	.750	.811	.717	.250	.847	.438	.375	.765	.000	.769	.750	.864	.650	.000	.850	.881

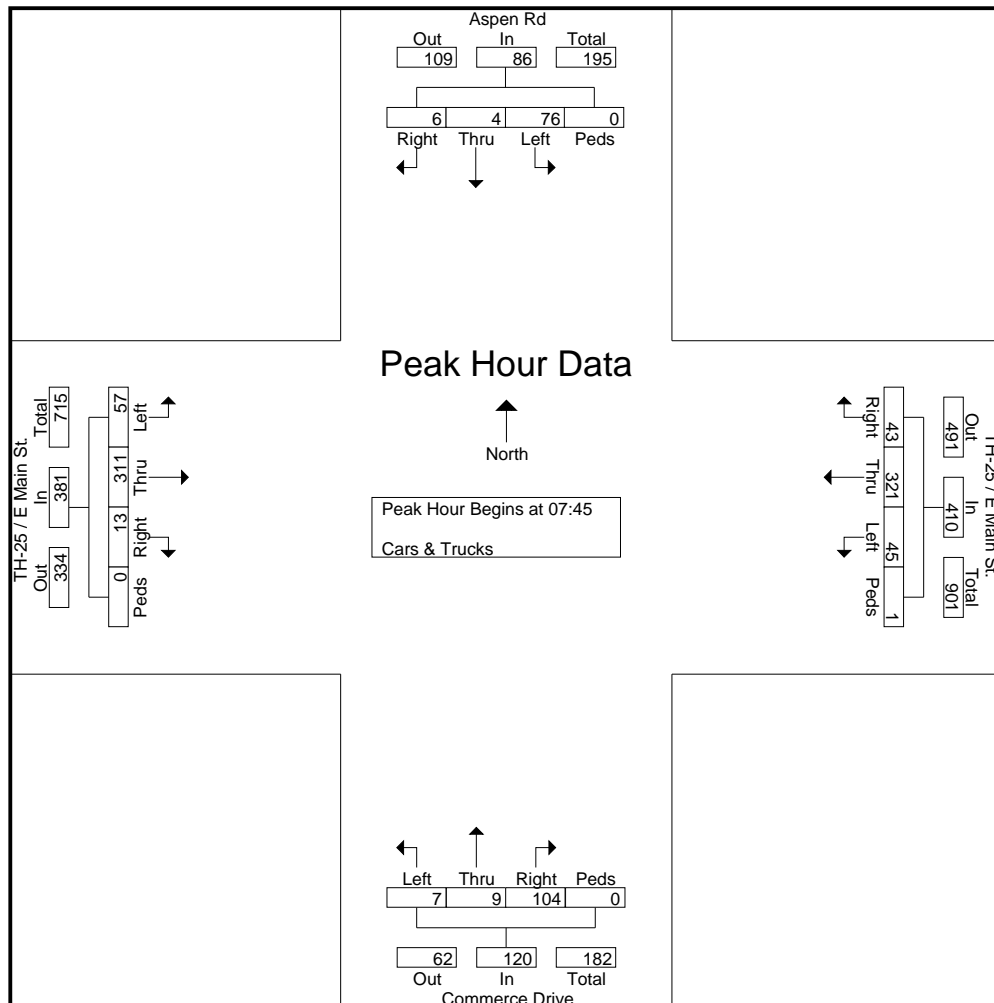



# MINNESOTA DEPT OF TRANSPORTATION

## TRAFFIC DATA COLLECTION - METRO

TH-25 at Aspen Rd/Commerce Drive  
 Ref.Pt.: 000.038  
 JAMAR # 632 CP  
 TURN MOVEMENT COUNT

File Name : TH-25 at Commerce Dr- Aspen Rd 2010  
 Site Code : 00000000  
 Start Date : 3/18/2010  
 Page No : 3

Start Time	Aspen Rd Southbound					TH-25 / E Main St. Westbound					Commerce Drive Northbound					TH-25 / E Main St. Eastbound					Int. Total
	Left	Thru	Right	Peds	App. Total	Left	Thru	Right	Peds	App. Total	Left	Thru	Right	Peds	App. Total	Left	Thru	Right	Peds	App. Total	

Peak Hour Analysis From 15:00 to 17:45 - Peak 1 of 1  
 Peak Hour for Entire Intersection Begins at 16:00

16:00	14	2	4	0	20	7	106	11	1	125	6	4	29	0	39	18	88	3	0	109	293
16:15	11	1	5	0	17	7	91	15	0	113	2	5	13	0	20	16	103	2	0	121	271
16:30	12	1	2	0	15	10	100	20	1	131	1	5	8	1	15	13	109	3	0	125	286
16:45	17	3	4	0	24	7	127	22	0	156	2	3	10	0	15	23	80	1	0	104	299
Total Volume	54	7	15	0	76	31	424	68	2	525	11	17	60	1	89	70	380	9	0	459	1149
% App. Total	71.1	9.2	19.7	0		5.9	80.8	13	0.4		12.4	19.1	67.4	1.1		15.3	82.8	2	0		
PHF	.794	.583	.750	.000	.792	.775	.835	.773	.500	.841	.458	.850	.517	.250	.571	.761	.872	.750	.000	.918	.961

