

SEH CONSULTING
Traffic Data Collection
TURN MOVEMENT COUNT

TH-36 at TH-120 / Century Ave.
Ref.Pt.: 010.463
data by SEH
TURN MOVEMENT COUNT

File Name : TH-36 at TH-120 2008
Site Code : 00000002
Start Date : 12/3/2008
Page No : 1

Groups Printed- Unshifted - Heavy Veh

Start Time	TH-120 / Century Ave Southbound				TH-36 Westbound				TH-120 / Century Ave Northbound				TH-36 Eastbound				Int. Total
	Left	Thru	Right	Peds	Left	Thru	Right	Peds	Left	Thru	Right	Peds	Left	Thru	Right	Peds	
06:00	5	27	25	0	7	189	4	0	35	24	6	0	3	30	7	0	362
06:15	8	25	28	0	5	235	1	0	46	48	5	0	11	60	16	0	488
06:30	11	39	30	0	17	334	5	0	70	54	16	0	10	69	12	0	667
06:45	9	37	27	0	16	355	4	0	57	46	17	0	17	113	13	0	711
Total	33	128	110	0	45	1113	14	0	208	172	44	0	41	272	48	0	2228
07:00	16	50	41	0	7	413	6	1	69	64	18	0	22	116	11	0	834
07:15	15	52	29	0	10	436	7	0	51	74	14	0	38	132	11	0	869
07:30	19	45	48	0	12	350	16	0	68	64	12	0	39	171	27	0	871
07:45	25	39	25	0	12	438	28	0	68	69	14	0	35	156	19	0	928
Total	75	186	143	0	41	1637	57	1	256	271	58	0	134	575	68	0	3502
08:00	17	43	29	0	14	369	16	0	62	44	18	0	36	159	16	0	823
08:15	21	46	30	0	18	288	13	2	50	81	15	0	30	138	35	0	767
08:30	17	49	22	0	15	274	14	0	39	75	22	0	65	119	59	0	770
08:45	25	29	28	0	19	271	32	0	58	68	11	0	40	139	28	0	748
Total	80	167	109	0	66	1202	75	2	209	268	66	0	171	555	138	0	3108
*** BREAK ***																	
11:00	9	53	35	0	11	154	2	0	25	53	28	0	16	143	39	0	568
11:15	12	41	24	0	17	162	9	0	33	60	22	0	21	151	29	0	581
11:30	21	45	28	0	16	166	7	0	40	58	22	0	32	184	40	0	659
11:45	27	42	32	0	13	187	5	0	35	46	23	0	44	163	43	0	660
Total	69	181	119	0	57	669	23	0	133	217	95	0	113	641	151	0	2468
12:00	17	61	34	0	17	124	5	0	31	52	14	0	24	110	35	0	524
12:15	16	49	27	0	28	151	5	0	32	48	20	0	31	136	35	0	578
12:30	6	59	19	0	18	188	4	0	37	47	24	0	37	157	37	0	633
12:45	40	67	40	0	29	212	9	0	50	57	16	0	49	144	38	0	751
Total	79	236	120	0	92	675	23	0	150	204	74	0	141	547	145	0	2486
*** BREAK ***																	
15:00	23	68	39	0	20	165	18	0	44	74	15	1	31	265	57	0	820
15:15	23	56	30	0	22	194	22	0	47	73	36	0	42	243	88	1	877
15:30	18	68	28	0	26	240	32	0	50	75	32	16	43	318	74	4	1024
15:45	39	82	36	0	24	165	13	0	46	62	31	6	40	305	76	0	925
Total	103	274	133	0	92	764	85	0	187	284	114	23	156	1131	295	5	3646
16:00	22	60	32	0	34	215	8	1	39	55	30	0	57	357	69	0	979
16:15	46	61	29	0	26	205	11	0	39	71	32	1	30	389	75	1	1016
16:30	31	66	23	0	31	200	8	0	50	86	28	0	61	331	69	1	985
16:45	27	74	25	0	25	249	7	0	37	87	40	1	61	370	67	0	1070
Total	126	261	109	0	116	869	34	1	165	299	130	2	209	1447	280	2	4050
17:00	35	66	33	0	22	246	4	0	45	92	40	0	65	366	68	0	1082
17:15	22	76	29	0	19	228	15	0	51	96	41	0	74	362	70	0	1083
17:30	19	85	33	0	16	187	9	0	44	73	17	0	62	360	65	0	970
17:45	25	77	23	0	12	177	16	0	50	98	24	0	52	297	49	0	900
Total	101	304	118	0	69	838	44	0	190	359	122	0	253	1385	252	0	4035
Grand Total	666	1737	961	0	578	7767	355	4	1498	2074	703	25	1218	6553	1377	7	25523
Apprch %	19.8	51.6	28.6	0	6.6	89.2	4.1	0	34.8	48.2	16.3	0.6	13.3	71.6	15	0.1	
Total %	2.6	6.8	3.8	0	2.3	30.4	1.4	0	5.9	8.1	2.8	0.1	4.8	25.7	5.4	0	
Unshifted	657	1723	954	0	567	7668	344	4	1479	2057	694	25	1209	6428	1346	7	25162
% Unshifted	98.6	99.2	99.3	0	98.1	98.7	96.9	100	98.7	99.2	98.7	100	99.3	98.1	97.7	100	98.6
Heavy Veh	9	14	7	0	11	99	11	0	19	17	9	0	9	125	31	0	361
% Heavy Veh	1.4	0.8	0.7	0	1.9	1.3	3.1	0	1.3	0.8	1.3	0	0.7	1.9	2.3	0	1.4

SEH CONSULTING
Traffic Data Collection
TURN MOVEMENT COUNT

TH-36 at TH-120 / Century Ave.
Ref.Pt.: 010.463
data by SEH
TURN MOVEMENT COUNT

File Name : TH-36 at TH-120 2008
Site Code : 00000002
Start Date : 12/3/2008
Page No : 2

Start Time	TH-120 / Century Ave Southbound					TH-36 Westbound					TH-120 / Century Ave Northbound					TH-36 Eastbound					Int. Total
	Left	Thru	Right	Peds	App. Total	Left	Thru	Right	Peds	App. Total	Left	Thru	Right	Peds	App. Total	Left	Thru	Right	Peds	App. Total	
Peak Hour Analysis From 06:00 to 08:45 - Peak 1 of 1																					
Peak Hour for Entire Intersection Begins at 07:00																					
07:00	16	50	41	0	107	7	413	6	1	427	69	64	18	0	151	22	116	11	0	149	834
07:15	15	52	29	0	96	10	436	7	0	453	51	74	14	0	139	38	132	11	0	181	869
07:30	19	45	48	0	112	12	350	16	0	378	68	64	12	0	144	39	171	27	0	237	871
07:45	25	39	25	0	89	12	438	28	0	478	68	69	14	0	151	35	156	19	0	210	928
Total Volume	75	186	143	0	404	41	1637	57	1	1736	256	271	58	0	585	134	575	68	0	777	3502
% App. Total	18.6	46	35.4	0		2.4	94.3	3.3	0.1		43.8	46.3	9.9	0		17.2	74	8.8	0		
PHF	.750	.894	.745	.000	.902	.854	.934	.509	.250	.908	.928	.916	.806	.000	.969	.859	.841	.630	.000	.820	.943

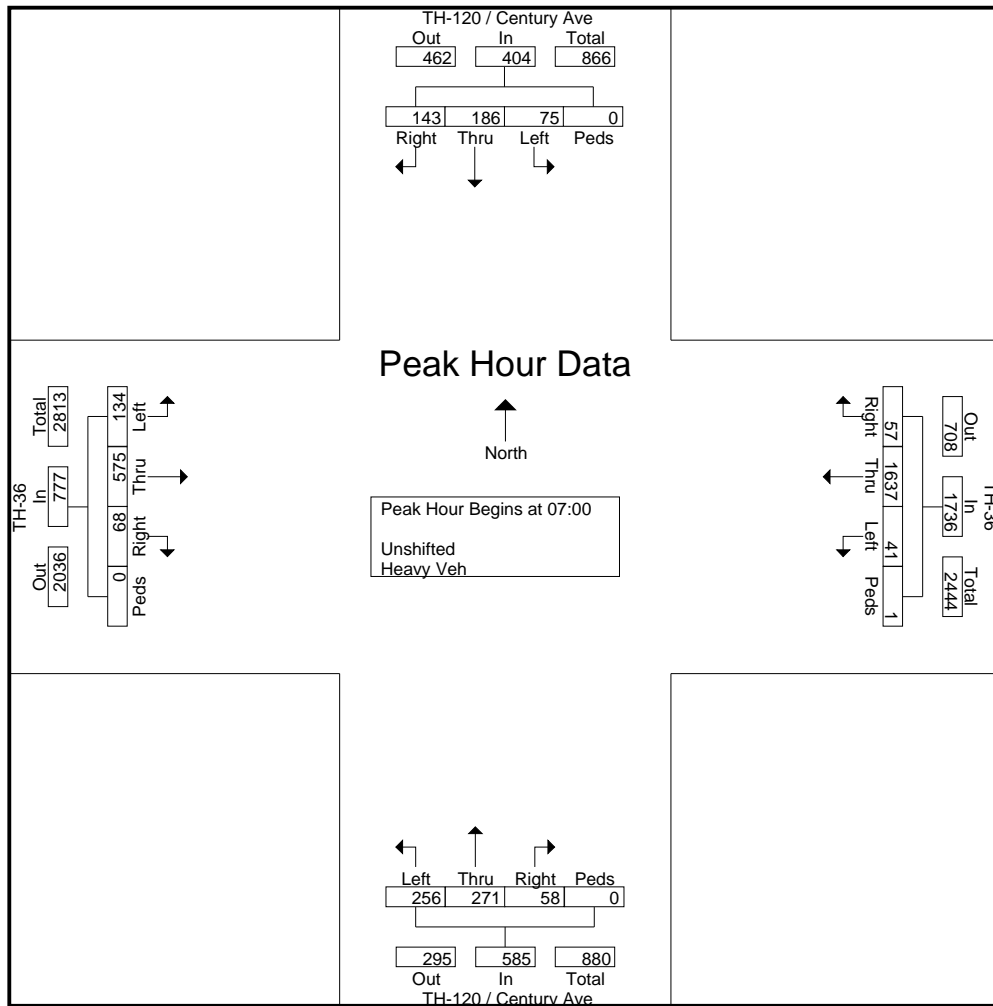

SEH CONSULTING
Traffic Data Collection
TURN MOVEMENT COUNT

TH-36 at TH-120 / Century Ave.
Ref.Pt.: 010.463
data by SEH
TURN MOVEMENT COUNT

File Name : TH-36 at TH-120 2008
Site Code : 00000002
Start Date : 12/3/2008
Page No : 3

Start Time	TH-120 / Century Ave Southbound					TH-36 Westbound					TH-120 / Century Ave Northbound					TH-36 Eastbound					Int. Total
	Left	Thru	Right	Peds	App. Total	Left	Thru	Right	Peds	App. Total	Left	Thru	Right	Peds	App. Total	Left	Thru	Right	Peds	App. Total	
Peak Hour Analysis From 15:00 to 17:45 - Peak 1 of 1																					
Peak Hour for Entire Intersection Begins at 16:30																					
16:30	31	66	23	0	120	31	200	8	0	239	50	86	28	0	164	61	331	69	1	462	985
16:45	27	74	25	0	126	25	249	7	0	281	37	87	40	1	165	61	370	67	0	498	1070
17:00	35	66	33	0	134	22	246	4	0	272	45	92	40	0	177	65	366	68	0	499	1082
17:15	22	76	29	0	127	19	228	15	0	262	51	96	41	0	188	74	362	70	0	506	1083
Total Volume	115	282	110	0	507	97	923	34	0	1054	183	361	149	1	694	261	1429	274	1	1965	4220
% App. Total	22.7	55.6	21.7	0		9.2	87.6	3.2	0		26.4	52	21.5	0.1		13.3	72.7	13.9	0.1		
PHF	.821	.928	.833	.000	.946	.782	.927	.567	.000	.938	.897	.940	.909	.250	.923	.882	.966	.979	.250	.971	.974

