

SEH CONSULTING  
Traffic Data Collection  
TURN MOVEMENT COUNT

TH-36 and Greeley St/Oakgreen Ave N  
Ref.Pt.: 202.419  
data by SEH  
TURN MOVEMENT COUNT

File Name : TH-36 at Oakgreen-Greeley 2008  
Site Code : 00000009  
Start Date : 12/17/2008  
Page No : 1

Groups Printed- Unshifted - Heavy Veh

Start Time	Greeley Street Southbound				TH-36 Westbound				Oakgreen Ave Northbound				TH-36 Eastbound				Int. Total
	Left	Thru	Right	Peds	Left	Thru	Right	Peds	Left	Thru	Right	Peds	Left	Thru	Right	Peds	
06:00	51	12	23	0	47	169	21	0	9	3	5	0	0	75	3	0	418
06:15	8	3	23	0	2	172	6	0	14	4	4	0	8	121	2	0	367
06:30	7	5	12	0	4	190	13	0	15	8	7	0	18	123	3	0	405
06:45	13	3	18	0	6	188	19	1	17	16	6	0	29	136	7	0	459
Total	79	23	76	0	59	719	59	1	55	31	22	0	55	455	15	0	1649
07:00	20	7	23	0	8	165	3	0	24	19	10	0	26	109	4	0	418
07:15	11	6	18	0	7	187	34	0	17	50	10	0	42	143	2	0	527
07:30	23	5	17	0	2	171	13	0	26	19	24	0	33	179	7	0	519
07:45	9	13	14	0	15	172	48	0	23	39	5	0	49	203	10	0	600
Total	63	31	72	0	32	695	98	0	90	127	49	0	150	634	23	0	2064
08:00	16	2	19	0	1	136	30	0	16	14	3	0	31	111	14	0	393
08:15	27	17	23	0	14	120	31	0	10	18	11	0	28	112	8	0	419
08:30	28	9	15	0	25	112	19	0	11	31	8	0	31	205	13	0	507
08:45	21	5	19	0	12	126	23	0	26	44	7	0	34	147	6	0	470
Total	92	33	76	0	52	494	103	0	63	107	29	0	124	575	41	0	1789
*** BREAK ***																	
11:00	33	25	47	0	19	199	38	0	0	0	0	0	0	0	0	0	361
11:15	41	24	27	0	22	195	34	0	18	35	21	0	37	164	5	0	623
11:30	48	30	36	0	20	179	38	0	26	28	24	0	26	178	2	0	635
11:45	55	31	36	0	27	204	33	0	33	42	23	0	45	157	11	0	697
Total	177	110	146	0	88	777	143	0	77	105	68	0	108	499	18	0	2316
12:00	40	40	28	0	20	160	24	0	34	45	34	0	33	169	16	0	643
12:15	28	32	40	0	27	208	36	0	29	39	21	0	40	189	16	0	705
12:30	41	36	27	0	22	187	29	0	22	30	29	0	39	195	11	0	668
12:45	46	38	32	0	32	203	36	0	38	30	24	0	37	215	7	1	739
Total	155	146	127	0	101	758	125	0	123	144	108	0	149	768	50	1	2755
*** BREAK ***																	
15:00	44	46	37	0	20	269	34	0	28	37	39	0	44	259	16	1	874
15:15	47	36	35	0	27	265	54	0	33	59	27	0	56	267	24	0	930
15:30	42	41	54	0	32	305	45	0	38	62	30	0	44	248	24	0	965
15:45	48	37	42	0	20	204	40	0	30	38	35	0	54	298	32	0	878
Total	181	160	168	0	99	1043	173	0	129	196	131	0	198	1072	96	1	3647
16:00	60	45	43	0	21	222	73	3	22	61	35	0	50	249	24	0	908
16:15	31	33	35	0	22	208	73	2	34	46	26	0	45	251	25	0	831
16:30	65	54	62	0	22	258	36	0	33	50	37	0	43	315	26	0	1001
16:45	56	40	35	0	20	234	26	0	32	43	37	0	44	312	28	0	907
Total	212	172	175	0	85	922	208	5	121	200	135	0	182	1127	103	0	3647
17:00	71	34	45	0	12	206	31	0	33	40	30	0	42	265	18	0	827
17:15	35	36	44	0	23	231	20	0	38	44	37	0	32	266	22	0	828
17:30	52	28	39	0	13	164	25	0	36	33	29	0	56	275	22	1	773
17:45	48	36	25	0	12	144	21	0	27	56	21	1	42	238	16	0	687
Total	206	134	153	0	60	745	97	0	134	173	117	1	172	1044	78	1	3115
Grand Total	1165	809	993	0	576	6153	1006	6	792	1083	659	1	1138	6174	424	3	20982
Apprch %	39.3	27.3	33.5	0	7.4	79.5	13	0.1	31.2	42.7	26	0	14.7	79.8	5.5	0	
Total %	5.6	3.9	4.7	0	2.7	29.3	4.8	0	3.8	5.2	3.1	0	5.4	29.4	2	0	
Unshifted	1161	809	988	0	567	6082	999	6	787	1077	657	1	1132	6085	419	3	20773
% Unshifted	99.7	100	99.5	0	98.4	98.8	99.3	100	99.4	99.4	99.7	100	99.5	98.6	98.8	100	99
Heavy Veh	4	0	5	0	9	71	7	0	5	6	2	0	6	89	5	0	209
% Heavy Veh	0.3	0	0.5	0	1.6	1.2	0.7	0	0.6	0.6	0.3	0	0.5	1.4	1.2	0	1

SEH CONSULTING  
Traffic Data Collection  
TURN MOVEMENT COUNT

TH-36 and Greeley St/Oakgreen Ave N  
Ref.Pt.: 202.419  
data by SEH  
TURN MOVEMENT COUNT

File Name : TH-36 at Oakgreen-Greeley 2008  
Site Code : 00000009  
Start Date : 12/17/2008  
Page No : 2

Start Time	Greeley Street Southbound					TH-36 Westbound					Oakgreen Ave Northbound					TH-36 Eastbound					Int. Total
	Left	Thru	Right	Peds	App. Total	Left	Thru	Right	Peds	App. Total	Left	Thru	Right	Peds	App. Total	Left	Thru	Right	Peds	App. Total	
Peak Hour Analysis From 06:00 to 08:45 - Peak 1 of 1																					
Peak Hour for Entire Intersection Begins at 07:00																					
07:00	20	7	23	0	50	8	165	3	0	176	24	19	10	0	53	26	109	4	0	139	418
07:15	11	6	18	0	35	7	187	34	0	228	17	50	10	0	77	42	143	2	0	187	527
07:30	23	5	17	0	45	2	171	13	0	186	26	19	24	0	69	33	179	7	0	219	519
07:45	9	13	14	0	36	15	172	48	0	235	23	39	5	0	67	49	203	10	0	262	600
Total Volume	63	31	72	0	166	32	695	98	0	825	90	127	49	0	266	150	634	23	0	807	2064
% App. Total	38	18.7	43.4	0		3.9	84.2	11.9	0		33.8	47.7	18.4	0		18.6	78.6	2.9	0		
PHF	.685	.596	.783	.000	.830	.533	.929	.510	.000	.878	.865	.635	.510	.000	.864	.765	.781	.575	.000	.770	.860

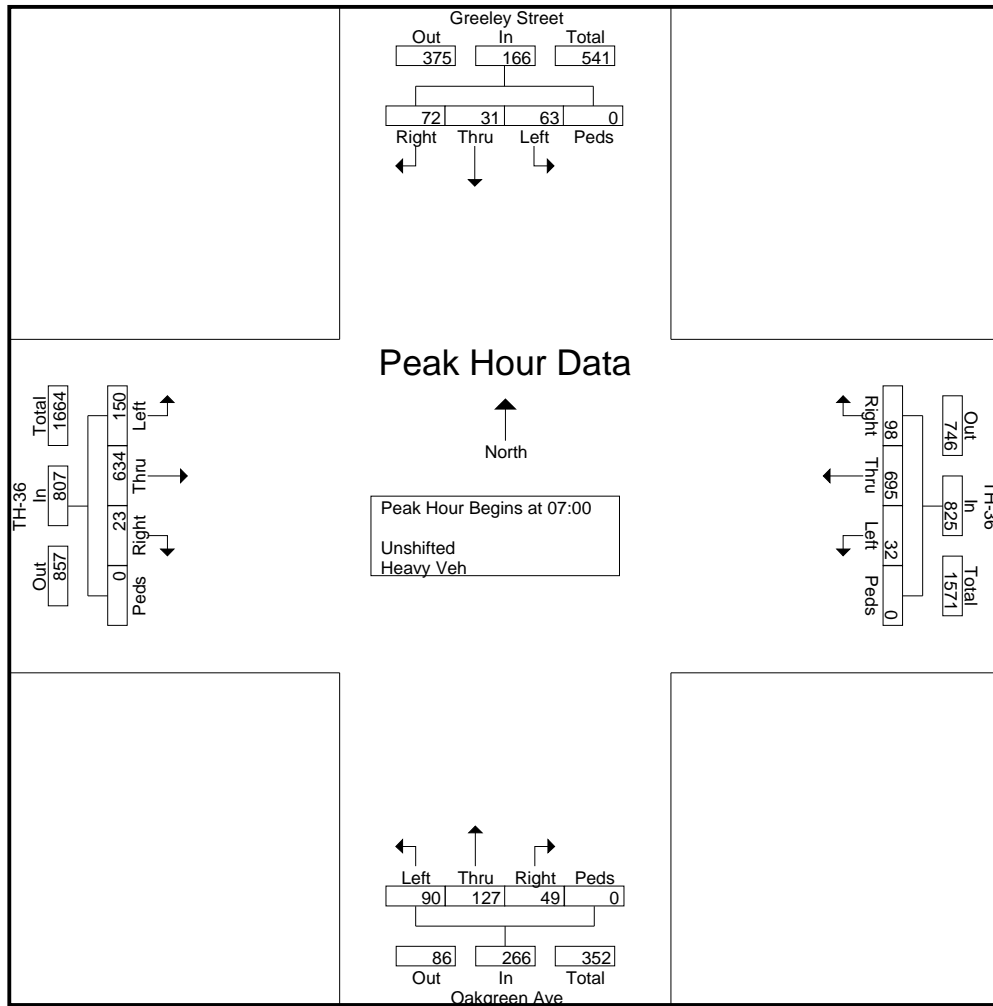

SEH CONSULTING  
Traffic Data Collection  
TURN MOVEMENT COUNT

TH-36 and Greeley St/Oakgreen Ave N  
Ref.Pt.: 202.419  
data by SEH  
TURN MOVEMENT COUNT

File Name : TH-36 at Oakgreen-Greeley 2008  
Site Code : 00000009  
Start Date : 12/17/2008  
Page No : 3

Start Time	Greeley Street Southbound					TH-36 Westbound					Oakgreen Ave Northbound					TH-36 Eastbound					Int. Total
	Left	Thru	Right	Peds	App. Total	Left	Thru	Right	Peds	App. Total	Left	Thru	Right	Peds	App. Total	Left	Thru	Right	Peds	App. Total	

Peak Hour Analysis From 15:00 to 17:45 - Peak 1 of 1

Peak Hour for Entire Intersection Begins at 15:15

15:15	47	36	35	0	118	27	265	54	0	346	33	59	27	0	119	56	267	24	0	347	930
15:30	42	41	54	0	137	32	305	45	0	382	38	62	30	0	130	44	248	24	0	316	965
15:45	48	37	42	0	127	20	204	40	0	264	30	38	35	0	103	54	298	32	0	384	878
16:00	60	45	43	0	148	21	222	73	3	319	22	61	35	0	118	50	249	24	0	323	908
Total Volume	197	159	174	0	530	100	996	212	3	1311	123	220	127	0	470	204	1062	104	0	1370	3681
% App. Total	37.2	30	32.8	0		7.6	76	16.2	0.2		26.2	46.8	27	0		14.9	77.5	7.6	0		
PHF	.821	.883	.806	.000	.895	.781	.816	.726	.250	.858	.809	.887	.907	.000	.904	.911	.891	.813	.000	.892	.954

