

SEH CONSULTING  
Traffic Data Collection  
TURN MOVEMENT COUNT

TH-36 at Osgood Ave N  
Ref.Pt.: 203.146  
data by SEH  
TURN MOVEMENT COUNT

File Name : TH-36 at Osgood Ave N 2008  
Site Code : 00000010  
Start Date : 12/17/2008  
Page No : 1

Groups Printed- Unshifted - Heavy Veh

Start Time	Osgood Ave N Southbound				TH-36 Westbound				Osgood Ave N Northbound				TH-36 Eastbound				Int. Total
	Left	Thru	Right	Peds	Left	Thru	Right	Peds	Left	Thru	Right	Peds	Left	Thru	Right	Peds	
06:00	0	4	20	0	15	139	0	0	21	7	7	0	7	56	16	0	292
06:15	0	17	20	0	20	178	2	0	23	17	8	0	14	78	21	0	398
06:30	0	16	12	0	19	190	2	2	22	21	12	0	32	68	29	0	425
06:45	0	18	14	0	38	166	4	0	47	42	15	0	57	59	19	3	482
Total	0	55	66	0	92	673	8	2	113	87	42	0	110	261	85	3	1597
07:00	0	28	24	0	31	222	5	1	48	33	9	0	40	78	19	0	538
07:15	3	38	45	0	36	190	4	0	56	48	10	0	65	72	14	0	581
07:30	4	40	47	0	43	207	5	0	73	58	15	0	69	57	8	0	626
07:45	9	49	43	0	43	180	11	0	54	45	11	0	102	87	21	0	655
Total	16	155	159	0	153	799	25	1	231	184	45	0	276	294	62	0	2400
08:00	2	46	47	0	37	178	14	0	42	33	4	0	61	67	16	0	547
08:15	1	29	50	0	29	147	11	0	36	47	6	0	53	56	20	1	486
08:30	6	57	60	0	41	125	8	0	43	38	7	0	50	42	24	0	501
08:45	7	48	32	0	33	142	4	0	45	40	15	0	34	61	18	0	479
Total	16	180	189	0	140	592	37	0	166	158	32	0	198	226	78	1	2013
*** BREAK ***																	
11:00	6	29	45	0	24	150	12	1	65	21	17	0	36	79	41	1	527
11:15	3	44	55	0	24	156	11	0	52	28	13	0	48	106	45	0	585
11:30	8	33	77	4	22	111	10	0	44	22	25	0	45	107	43	0	551
11:45	8	37	56	5	27	142	10	0	58	42	16	0	61	112	44	0	618
Total	25	143	233	9	97	559	43	1	219	113	71	0	190	404	173	1	2281
12:00	8	42	70	0	31	91	5	0	34	29	33	0	63	107	51	0	564
12:15	7	41	59	0	33	151	10	0	52	46	22	0	70	109	36	0	636
12:30	1	45	47	0	21	122	9	0	42	36	15	0	81	117	38	0	574
12:45	6	43	53	0	20	157	8	3	50	36	17	0	95	124	45	0	657
Total	22	171	229	0	105	521	32	3	178	147	87	0	309	457	170	0	2431
*** BREAK ***																	
15:00	8	78	85	0	25	158	8	0	42	47	22	1	80	160	44	0	758
15:15	7	67	5	0	24	151	9	0	88	84	19	1	79	140	48	0	722
15:30	6	81	0	0	23	145	10	0	70	73	20	0	87	160	55	0	730
15:45	8	65	0	0	21	138	5	0	53	70	23	0	98	184	61	0	726
Total	29	291	90	0	93	592	32	0	253	274	84	2	344	644	208	0	2936
16:00	2	40	93	0	23	123	6	0	55	35	21	0	60	170	75	0	703
16:15	9	38	60	0	20	138	6	1	58	45	31	0	105	155	51	0	717
16:30	2	50	50	0	11	132	5	0	56	58	27	0	81	196	83	0	751
16:45	8	61	65	0	13	130	13	0	59	48	16	0	88	211	85	0	797
Total	21	189	268	0	67	523	30	1	228	186	95	0	334	732	294	0	2968
17:00	8	88	87	0	17	132	11	0	57	52	22	0	72	176	82	3	807
17:15	4	55	57	0	8	133	15	0	48	54	24	0	75	189	73	0	735
17:30	7	56	47	0	21	99	12	0	44	53	22	0	91	151	61	0	664
17:45	4	36	56	0	19	99	10	0	43	52	14	0	74	155	53	0	615
Total	23	235	247	0	65	463	48	0	192	211	82	0	312	671	269	3	2821
Grand Total	152	1419	1481	9	812	4722	255	8	1580	1360	538	2	2073	3689	1339	8	19447
Apprch %	5	46.4	48.4	0.3	14	81.5	4.4	0.1	45.4	39.1	15.5	0.1	29.2	51.9	18.8	0.1	
Total %	0.8	7.3	7.6	0	4.2	24.3	1.3	0	8.1	7	2.8	0	10.7	19	6.9	0	
Unshifted	150	1414	1472	9	809	4651	253	8	1575	1348	537	2	2055	3634	1329	8	19254
% Unshifted	98.7	99.6	99.4	100	99.6	98.5	99.2	100	99.7	99.1	99.8	100	99.1	98.5	99.3	100	99
Heavy Veh	2	5	9	0	3	71	2	0	5	12	1	0	18	55	10	0	193
% Heavy Veh	1.3	0.4	0.6	0	0.4	1.5	0.8	0	0.3	0.9	0.2	0	0.9	1.5	0.7	0	1

SEH CONSULTING  
Traffic Data Collection  
TURN MOVEMENT COUNT

TH-36 at Osgood Ave N  
Ref.Pt.: 203.146  
data by SEH  
TURN MOVEMENT COUNT

File Name : TH-36 at Osgood Ave N 2008  
Site Code : 00000010  
Start Date : 12/17/2008  
Page No : 2

Start Time	Osgood Ave N Southbound					TH-36 Westbound					Osgood Ave N Northbound					TH-36 Eastbound					Int. Total
	Left	Thru	Right	Peds	App. Total	Left	Thru	Right	Peds	App. Total	Left	Thru	Right	Peds	App. Total	Left	Thru	Right	Peds	App. Total	
Peak Hour Analysis From 06:00 to 08:45 - Peak 1 of 1																					
Peak Hour for Entire Intersection Begins at 07:15																					
07:15	3	38	45	0	86	36	190	4	0	230	56	48	10	0	114	65	72	14	0	151	581
07:30	4	40	47	0	91	43	207	5	0	255	73	58	15	0	146	69	57	8	0	134	626
07:45	9	49	43	0	101	43	180	11	0	234	54	45	11	0	110	102	87	21	0	210	655
08:00	2	46	47	0	95	37	178	14	0	229	42	33	4	0	79	61	67	16	0	144	547
Total Volume	18	173	182	0	373	159	755	34	0	948	225	184	40	0	449	297	283	59	0	639	2409
% App. Total	4.8	46.4	48.8	0		16.8	79.6	3.6	0		50.1	41	8.9	0		46.5	44.3	9.2	0		
PHF	.500	.883	.968	.000	.923	.924	.912	.607	.000	.929	.771	.793	.667	.000	.769	.728	.813	.702	.000	.761	.919

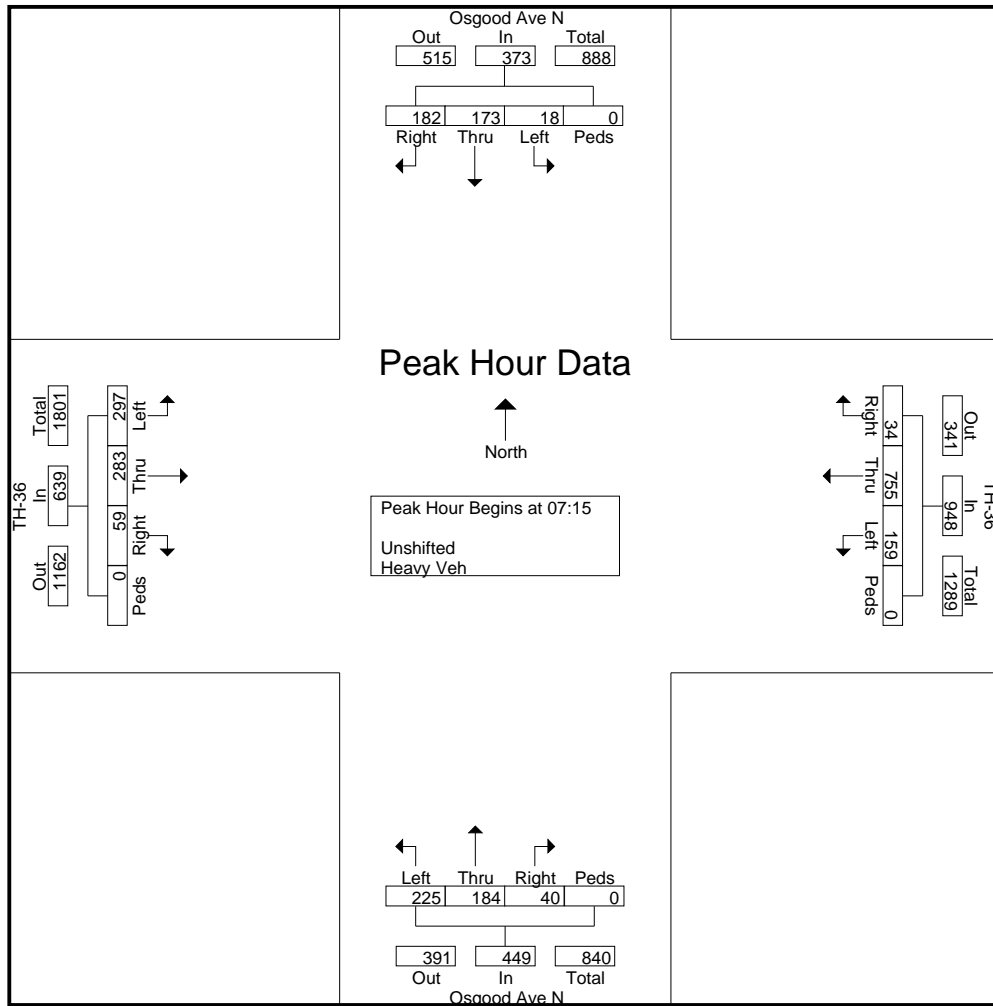

SEH CONSULTING  
Traffic Data Collection  
TURN MOVEMENT COUNT

TH-36 at Osgood Ave N  
Ref.Pt.: 203.146  
data by SEH  
TURN MOVEMENT COUNT

File Name : TH-36 at Osgood Ave N 2008  
Site Code : 00000010  
Start Date : 12/17/2008  
Page No : 3

Start Time	Osgood Ave N Southbound					TH-36 Westbound					Osgood Ave N Northbound					TH-36 Eastbound					Int. Total
	Left	Thru	Right	Peds	App. Total	Left	Thru	Right	Peds	App. Total	Left	Thru	Right	Peds	App. Total	Left	Thru	Right	Peds	App. Total	

Peak Hour Analysis From 15:00 to 17:45 - Peak 1 of 1

Peak Hour for Entire Intersection Begins at 16:30

16:30	2	50	50	0	102	11	132	5	0	148	56	58	27	0	141	81	196	83	0	360	751
16:45	8	61	65	0	134	13	130	13	0	156	59	48	16	0	123	88	211	85	0	384	797
17:00	8	88	87	0	183	17	132	11	0	160	57	52	22	0	131	72	176	82	3	333	807
17:15	4	55	57	0	116	8	133	15	0	156	48	54	24	0	126	75	189	73	0	337	735
Total Volume	22	254	259	0	535	49	527	44	0	620	220	212	89	0	521	316	772	323	3	1414	3090
% App. Total	4.1	47.5	48.4	0		7.9	85	7.1	0		42.2	40.7	17.1	0		22.3	54.6	22.8	0.2		
PHF	.688	.722	.744	.000	.731	.721	.991	.733	.000	.969	.932	.914	.824	.000	.924	.898	.915	.950	.250	.921	.957

