



MINNESOTA DEPT OF TRANSPORTATION

TRAFFIC DATA COLLECTION - METRO

TH-41 at Crosstown Blvd / Victoria Drive
 Ref.Pt.: 002.709 CHASKA
 video SP
 TURN MOVEMENT COUNT

File Name : TH-41 at Crosstown-Victoria 2013
 Site Code :
 Start Date : 10/22/2013
 Page No : 1

Groups Printed- Cars +

Start Time	TH-41 Southbound				Crosstown Blvd Westbound				TH-41 Northbound				Victoria Drive Eastbound				Int. Total
	Right	Thru	Left	Peds	Right	Thru	Left	Peds	Right	Thru	Left	Peds	Right	Thru	Left	Peds	
06:00	3	44	1	0	9	2	2	0	0	47	2	0	11	3	9	0	133
06:15	1	59	0	0	15	0	2	0	0	112	3	0	9	2	7	0	210
06:30	0	70	2	0	22	4	3	0	0	120	5	0	22	3	12	0	263
06:45	0	86	5	0	20	5	2	0	2	198	4	0	15	5	8	0	350
Total	4	259	8	0	66	11	9	0	2	477	14	0	57	13	36	0	956
07:00	3	101	5	0	23	4	1	0	3	154	2	0	17	5	10	0	328
07:15	3	104	6	0	17	4	1	0	0	190	5	0	24	5	9	0	368
07:30	4	122	6	0	31	6	3	0	1	182	4	0	29	5	9	0	402
07:45	5	120	8	0	28	5	2	0	0	227	5	0	40	9	20	0	469
Total	15	447	25	0	99	19	7	0	4	753	16	0	110	24	48	0	1567
08:00	7	144	5	0	16	5	2	0	0	155	2	0	20	8	8	0	372
08:15	3	124	7	0	15	3	2	0	3	177	7	0	21	4	6	0	372
08:30	7	122	3	0	16	4	3	0	0	158	6	0	25	7	6	0	357
08:45	4	125	10	0	17	0	1	0	3	150	4	0	23	8	10	0	355
Total	21	515	25	0	64	12	8	0	6	640	19	0	89	27	30	0	1456
*****BREAK*****																	
11:00	5	115	6	0	8	3	1	0	1	102	9	0	15	3	3	0	271
11:15	8	91	5	0	10	2	1	0	2	100	8	0	10	0	3	0	240
11:30	4	112	4	0	5	0	4	0	2	112	13	0	9	2	4	0	271
11:45	5	129	1	0	15	4	1	0	3	114	6	0	10	4	8	0	300
Total	22	447	16	0	38	9	7	0	8	428	36	0	44	9	18	0	1082
12:00	4	134	4	0	10	3	0	0	3	112	11	0	6	3	2	0	292
12:15	4	120	9	0	9	3	0	0	1	106	7	0	17	3	2	0	281
12:30	7	100	7	0	5	3	3	0	2	122	6	0	14	6	9	0	284
12:45	5	117	7	0	12	0	1	0	1	127	8	0	11	6	4	0	299
Total	20	471	27	0	36	9	4	0	7	467	32	0	48	18	17	0	1156
*****BREAK*****																	
15:00	5	139	5	0	12	10	2	0	3	143	10	0	19	1	5	0	354
15:15	2	197	10	0	8	4	3	0	6	138	18	0	21	8	3	0	418
15:30	3	189	12	0	9	3	0	0	5	169	14	0	21	6	5	0	436
15:45	4	194	14	0	11	6	1	0	5	154	9	0	17	6	4	0	425
Total	14	719	41	0	40	23	6	0	19	604	51	0	78	21	17	0	1633
16:00	11	201	15	0	14	7	2	0	5	153	18	0	22	7	5	0	460
16:15	8	187	16	0	14	4	2	0	5	164	16	0	24	6	4	0	450
16:30	11	195	14	0	13	10	2	0	3	181	27	0	26	2	6	0	490
16:45	5	221	19	0	12	12	3	0	8	187	30	0	26	8	10	0	541
Total	35	804	64	0	53	33	9	0	21	685	91	0	98	23	25	0	1941
17:00	10	201	16	0	13	3	10	0	10	188	20	0	28	6	9	0	514
17:15	7	222	17	0	15	8	2	0	4	193	29	0	28	6	6	0	537
17:30	7	182	22	0	9	10	1	0	6	192	18	0	15	6	5	0	473
17:45	14	175	38	0	20	4	7	0	8	145	18	0	22	12	10	0	473
Total	38	780	93	0	57	25	20	0	28	718	85	0	93	30	30	0	1997
Grand Total	169	4442	299	0	453	141	70	0	95	4772	344	0	617	165	221	0	11788
Apprch %	3.4	90.5	6.1	0	68.2	21.2	10.5	0	1.8	91.6	6.6	0	61.5	16.5	22	0	
Total %	1.4	37.7	2.5	0	3.8	1.2	0.6	0	0.8	40.5	2.9	0	5.2	1.4	1.9	0	



MINNESOTA DEPT OF TRANSPORTATION

TRAFFIC DATA COLLECTION - METRO

TH-41 at Crosstown Blvd / Victoria Drive
 Ref.Pt.: 002.709 CHASKA
 video SP
 TURN MOVEMENT COUNT

File Name : TH-41 at Crosstown-Victoria 2013
 Site Code :
 Start Date : 10/22/2013
 Page No : 2

Start Time	TH-41 Southbound					Crosstown Blvd Westbound					TH-41 Northbound					Victoria Drive Eastbound					Int. Total
	Right	Thru	Left	Peds	App. Total	Right	Thru	Left	Peds	App. Total	Right	Thru	Left	Peds	App. Total	Right	Thru	Left	Peds	App. Total	
Peak Hour Analysis From 06:00 to 08:45 - Peak 1 of 1																					
Peak Hour for Entire Intersection Begins at 07:30																					
07:30	4	122	6	0	132	31	6	3	0	40	1	182	4	0	187	29	5	9	0	43	402
07:45	5	120	8	0	133	28	5	2	0	35	0	227	5	0	232	40	9	20	0	69	469
08:00	7	144	5	0	156	16	5	2	0	23	0	155	2	0	157	20	8	8	0	36	372
08:15	3	124	7	0	134	15	3	2	0	20	3	177	7	0	187	21	4	6	0	31	372
Total Volume	19	510	26	0	555	90	19	9	0	118	4	741	18	0	763	110	26	43	0	179	1615
% App. Total	3.4	91.9	4.7	0		76.3	16.1	7.6	0		0.5	97.1	2.4	0		61.5	14.5	24	0		
PHF	.679	.885	.813	.000	.889	.726	.792	.750	.000	.738	.333	.816	.643	.000	.822	.688	.722	.538	.000	.649	.861

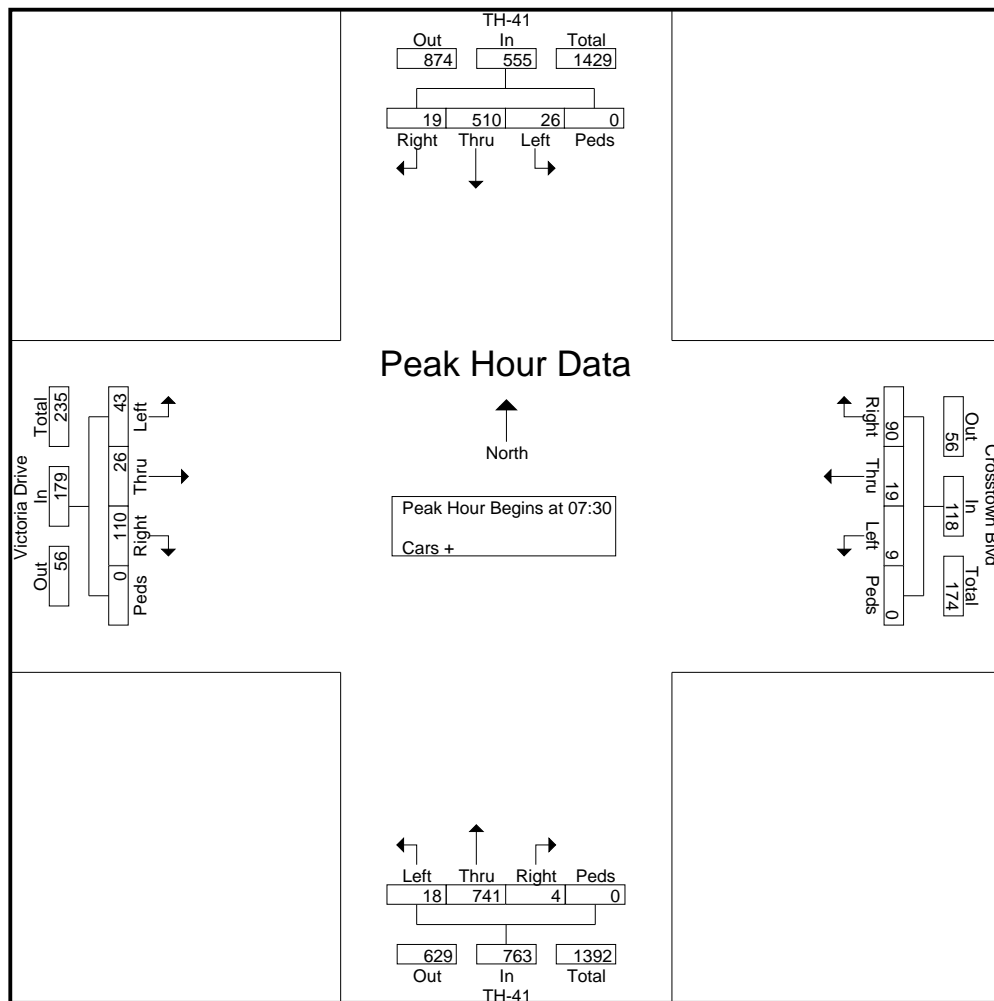



MINNESOTA DEPT OF TRANSPORTATION

TRAFFIC DATA COLLECTION - METRO

TH-41 at Crosstown Blvd / Victoria Drive
 Ref.Pt.: 002.709 CHASKA
 video SP
 TURN MOVEMENT COUNT

File Name : TH-41 at Crosstown-Victoria 2013
 Site Code :
 Start Date : 10/22/2013
 Page No : 3

Start Time	TH-41 Southbound					Crosstown Blvd Westbound					TH-41 Northbound					Victoria Drive Eastbound					Int. Total
	Rig ht	Thr u	Left	Ped s	App. Total	Rig ht	Thr u	Left	Ped s	App. Total	Right	Thr u	Left	Peds	App. Total	Right	Thr u	Left	Peds	App. Total	
Peak Hour Analysis From 15:00 to 17:45 - Peak 1 of 1																					
Peak Hour for Entire Intersection Begins at 16:30																					
16:30	11	195	14	0	220	13	10	2	0	25	3	181	27	0	211	26	2	6	0	34	490
16:45	5	221	19	0	245	12	12	3	0	27	8	187	30	0	225	26	8	10	0	44	541
17:00	10	201	16	0	227	13	3	10	0	26	10	188	20	0	218	28	6	9	0	43	514
17:15	7	222	17	0	246	15	8	2	0	25	4	193	29	0	226	28	6	6	0	40	537
Total Volume	33	839	66	0	938	53	33	17	0	103	25	749	106	0	880	108	22	31	0	161	2082
% App. Total	3.5	89.4	7	0		51.5	32	16.5	0		2.8	85.1	12	0		67.1	13.7	19.3	0		
PHF	.750	.945	.868	.000	.953	.883	.688	.425	.000	.954	.625	.970	.883	.000	.973	.964	.688	.775	.000	.915	.962

