



MINNESOTA DEPT OF TRANSPORTATION

TRAFFIC DATA COLLECTION - METRO

TH-41 at Pioneer Trail
 Ref.Pt.: 004.737
 Data by: Westwood Professional Services
 TURN MOVEMENT COUNT

File Name : TH-41 at Pioneer Trail 2008
 Site Code : 21052002
 Start Date : 10/2/2008
 Page No : 1

Groups Printed- Unshifted

Start Time	TH-41 Southbound				Pioneer Trail Westbound				TH-41 Northbound				Pioneer Trail Eastbound				Int. Total
	Left	Thru	Right	Peds	Left	Thru	Right	Peds	Left	Thru	Right	Peds	Left	Thru	Right	Peds	
06:00	13	14	1	0	4	8	27	0	8	88	13	0	13	22	17	0	228
06:15	12	15	2	0	10	7	25	0	17	114	7	0	20	17	19	0	265
06:30	37	63	3	0	9	22	37	0	14	134	8	0	27	28	36	0	418
06:45	30	39	3	0	14	30	42	0	31	167	22	1	38	38	54	0	509
Total	92	131	9	0	37	67	131	0	70	503	50	1	98	105	126	0	1420
07:00	39	54	9	0	18	41	35	0	31	147	25	0	34	64	73	0	570
07:15	23	41	10	0	8	22	41	0	30	151	24	0	47	71	51	0	519
07:30	41	49	6	0	12	29	44	0	21	200	22	0	52	126	65	0	667
07:45	52	56	2	0	21	35	44	0	19	186	25	0	52	136	38	0	666
Total	155	200	27	0	59	127	164	0	101	684	96	0	185	397	227	0	2422
08:00	35	51	6	0	25	35	52	0	23	132	36	0	28	48	34	0	505
08:15	20	50	10	0	17	31	42	0	34	140	33	0	35	44	52	0	508
08:30	24	63	11	0	37	29	26	0	26	116	28	0	31	48	46	0	485
08:45	31	51	12	0	25	23	40	0	30	182	27	0	28	18	35	0	502
Total	110	215	39	0	104	118	160	0	113	570	124	0	122	158	167	0	2000
*** BREAK ***																	
11:00	49	78	16	0	38	30	19	0	9	59	44	0	12	33	26	0	413
11:15	33	50	12	0	38	46	22	0	13	68	33	0	21	21	10	0	367
11:30	67	63	19	0	44	40	24	0	27	60	26	0	20	20	29	0	439
11:45	65	93	14	0	28	36	27	0	20	93	38	0	29	34	26	0	503
Total	214	284	61	0	148	152	92	0	69	280	141	0	82	108	91	0	1722
12:00	73	105	19	0	44	42	19	0	28	106	45	0	18	39	23	0	561
12:15	68	75	14	0	57	40	36	0	21	82	37	0	20	41	24	0	515
12:30	43	66	24	0	32	36	49	0	17	105	36	0	31	37	27	0	503
12:45	45	83	22	0	46	53	27	0	20	99	38	0	25	28	23	0	509
Total	229	329	79	0	179	171	131	0	86	392	156	0	94	145	97	0	2088
*** BREAK ***																	
15:00	63	137	23	0	59	92	31	0	29	80	27	0	24	52	29	0	646
15:15	68	107	28	0	62	97	35	0	31	101	40	0	28	48	38	0	683
15:30	67	104	51	0	58	82	33	0	27	90	33	0	20	58	25	0	648
15:45	70	111	36	0	46	72	37	0	40	116	50	0	19	45	25	0	667
Total	268	459	138	0	225	343	136	0	127	387	150	0	91	203	117	0	2644
16:00	70	115	41	0	41	61	34	0	36	118	43	0	20	42	24	0	645
16:15	54	119	47	0	42	81	29	0	44	98	45	0	23	45	28	0	655
16:30	79	127	52	0	41	89	33	0	65	95	50	0	12	50	29	0	722
16:45	91	103	37	0	48	75	18	0	58	95	51	0	35	59	34	0	704
Total	294	464	177	0	172	306	114	0	203	406	189	0	90	196	115	0	2726
17:00	72	143	49	0	52	99	29	0	39	97	39	0	22	62	28	0	731
17:15	67	103	40	0	62	87	29	0	58	103	39	0	25	45	32	0	690
17:30	58	101	33	0	61	111	33	0	64	120	47	0	35	58	38	0	759
17:45	59	133	31	0	64	102	41	0	66	131	46	0	25	46	37	0	781
Total	256	480	153	0	239	399	132	0	227	451	171	0	107	211	135	0	2961
Grand Total	1618	2562	683	0	1163	1683	1060	0	996	3673	1077	1	869	1523	1075	0	17983
Apprch %	33.3	52.7	14	0	29.8	43.1	27.1	0	17.3	63.9	18.7	0	25.1	43.9	31	0	
Total %	9	14.2	3.8	0	6.5	9.4	5.9	0	5.5	20.4	6	0	4.8	8.5	6	0	



MINNESOTA DEPT OF TRANSPORTATION

TRAFFIC DATA COLLECTION - METRO

TH-41 at Pioneer Trail
 Ref.Pt.: 004.737
 Data by: Westwood Professional Services
 TURN MOVEMENT COUNT

File Name : TH-41 at Pioneer Trail 2008
 Site Code : 21052002
 Start Date : 10/2/2008
 Page No : 2

Start Time	TH-41 Southbound					Pioneer Trail Westbound					TH-41 Northbound					Pioneer Trail Eastbound					Int. Total
	Left	Thru	Right	Peds	App. Total	Left	Thru	Right	Peds	App. Total	Left	Thru	Right	Peds	App. Total	Left	Thru	Right	Peds	App. Total	
Peak Hour Analysis From 06:00 to 08:45 - Peak 1 of 1																					
Peak Hour for Entire Intersection Begins at 07:00																					
07:00	39	54	9	0	102	18	41	35	0	94	31	147	25	0	203	34	64	73	0	171	570
07:15	23	41	10	0	74	8	22	41	0	71	30	151	24	0	205	47	71	51	0	169	519
07:30	41	49	6	0	96	12	29	44	0	85	21	200	22	0	243	52	126	65	0	243	667
07:45	52	56	2	0	110	21	35	44	0	100	19	186	25	0	230	52	136	38	0	226	666
Total Volume	155	200	27	0	382	59	127	164	0	350	101	684	96	0	881	185	397	227	0	809	2422
% App. Total	40.6	52.4	7.1	0		16.9	36.3	46.9	0		11.5	77.6	10.9	0		22.9	49.1	28.1	0		
PHF	.745	.893	.675	.000	.868	.702	.774	.932	.000	.875	.815	.855	.960	.000	.906	.889	.730	.777	.000	.832	.908

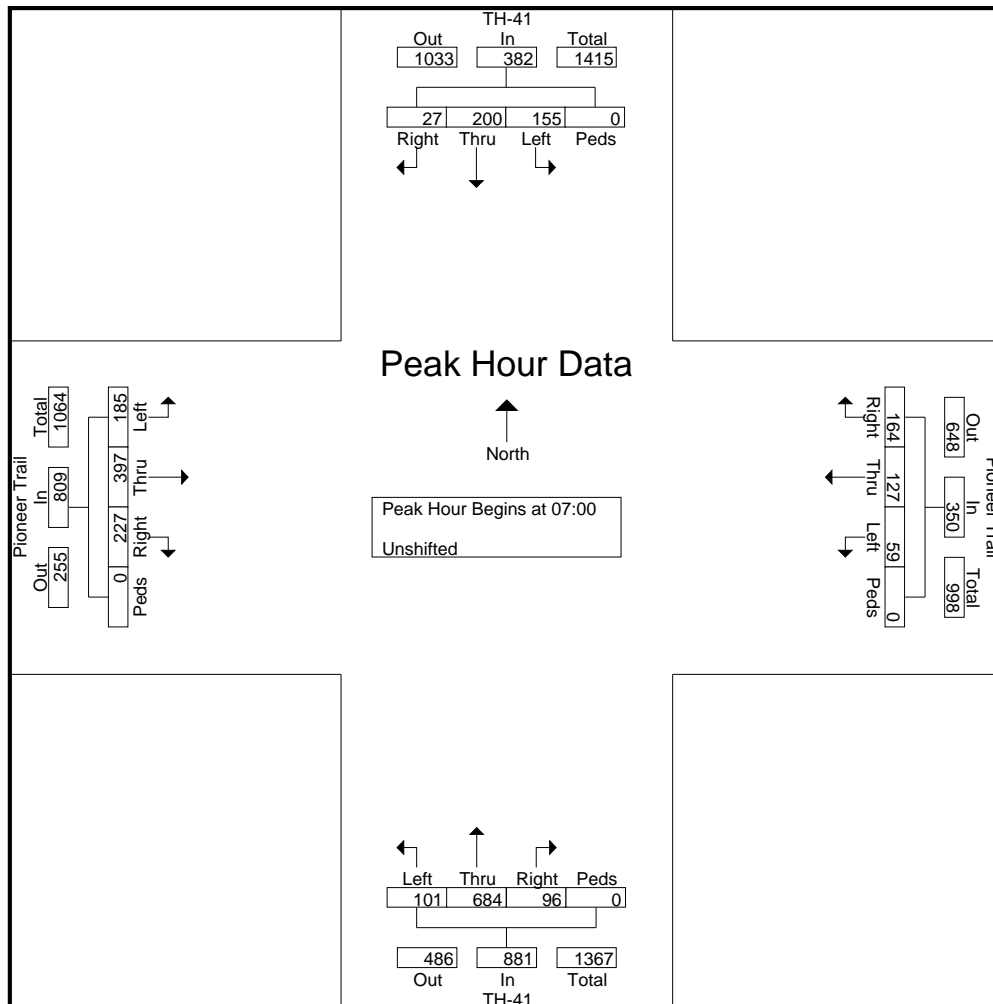



MINNESOTA DEPT OF TRANSPORTATION

TRAFFIC DATA COLLECTION - METRO

TH-41 at Pioneer Trail
 Ref.Pt.: 004.737
 Data by: Westwood Professional Services
 TURN MOVEMENT COUNT

File Name : TH-41 at Pioneer Trail 2008
 Site Code : 21052002
 Start Date : 10/2/2008
 Page No : 3

Start Time	TH-41 Southbound					Pioneer Trail Westbound					TH-41 Northbound					Pioneer Trail Eastbound					Int. Total
	Left	Thru	Right	Peds	App. Total	Left	Thru	Right	Peds	App. Total	Left	Thru	Right	Peds	App. Total	Left	Thru	Right	Peds	App. Total	
Peak Hour Analysis From 15:00 to 17:45 - Peak 1 of 1																					
Peak Hour for Entire Intersection Begins at 17:00																					
17:00	72	143	49	0	264	52	99	29	0	180	39	97	39	0	175	22	62	28	0	112	731
17:15	67	103	40	0	210	62	87	29	0	178	58	103	39	0	200	25	45	32	0	102	690
17:30	58	101	33	0	192	61	111	33	0	205	64	120	47	0	231	35	58	38	0	131	759
17:45	59	133	31	0	223	64	102	41	0	207	66	131	46	0	243	25	46	37	0	108	781
Total Volume	256	480	153	0	889	239	399	132	0	770	227	451	171	0	849	107	211	135	0	453	2961
% App. Total	28.8	54	17.2	0		31	51.8	17.1	0		26.7	53.1	20.1	0		23.6	46.6	29.8	0		
PHF	.889	.839	.781	.000	.842	.934	.899	.805	.000	.930	.860	.861	.910	.000	.873	.764	.851	.888	.000	.865	.948

