



MINNESOTA DEPT OF TRANSPORTATION

TRAFFIC DATA COLLECTION - METRO

TH-41 at Hazeltine Blvd.
 Ref.Pt.: 005.200
 Data by: Westwood Professional Services
 TURN MOVEMENT COUNT

File Name : TH-41 at Hazeltine Blvd 2008
 Site Code : 20052501
 Start Date : 10/1/2008
 Page No : 1

Groups Printed- Unshifted

Start Time	TH-41 Southbound				Hazeltine Blvd. Westbound				TH-41 Northbound				Hazeltine Blvd. Eastbound				Int. Total
	Left	Thru	Right	Peds	Left	Thru	Right	Peds	Left	Thru	Right	Peds	Left	Thru	Right	Peds	
06:00	7	30	0	0	2	0	2	0	1	100	2	0	0	0	1	0	145
06:15	4	47	1	0	4	0	5	0	2	152	6	0	0	0	1	0	222
06:30	12	94	1	0	4	0	10	0	0	206	7	0	0	0	1	0	335
06:45	14	62	2	0	6	0	16	0	8	194	12	0	1	0	1	0	316
Total	37	233	4	0	16	0	33	0	11	652	27	0	1	0	4	0	1018
07:00	11	91	0	0	3	0	13	0	2	199	11	0	0	0	1	0	331
07:15	22	81	0	0	2	0	17	0	0	213	10	1	1	0	0	0	347
07:30	11	90	1	0	5	0	15	0	0	282	32	0	1	1	1	0	439
07:45	35	99	0	0	8	0	19	0	0	176	22	0	2	0	0	0	361
Total	79	361	1	0	18	0	64	0	2	870	75	1	4	1	2	0	1478
08:00	39	84	1	0	19	0	18	0	3	154	27	0	2	0	2	0	349
08:15	25	82	0	0	11	0	14	0	1	152	37	0	0	0	1	0	323
08:30	23	100	1	0	15	1	26	0	1	165	24	0	1	0	1	0	358
08:45	33	81	0	0	17	0	23	0	1	133	33	0	1	1	0	0	323
Total	120	347	2	0	62	1	81	0	6	604	121	0	4	1	4	0	1353
*** BREAK ***																	
11:00	57	113	1	0	42	0	36	0	1	134	57	0	0	1	4	0	446
11:15	41	132	2	0	42	0	30	0	0	126	56	0	1	0	0	0	430
11:30	52	152	0	0	24	1	42	0	1	117	45	0	0	1	2	0	437
11:45	54	170	3	0	37	0	41	0	2	125	47	0	0	0	0	0	479
Total	204	567	6	0	145	1	149	0	4	502	205	0	1	2	6	0	1792
12:00	61	174	1	0	39	0	52	0	2	130	44	0	0	2	2	0	507
12:15	54	166	2	0	50	0	52	0	0	164	42	0	0	0	1	0	531
12:30	50	140	1	0	50	0	46	0	0	186	43	0	3	0	0	0	519
12:45	29	126	0	0	38	1	38	0	4	161	28	0	1	0	3	0	429
Total	194	606	4	0	177	1	188	0	6	641	157	0	4	2	6	0	1986
*** BREAK ***																	
15:00	28	208	0	0	29	0	43	0	3	138	25	0	0	0	2	0	476
15:15	39	167	0	0	30	0	29	0	1	144	26	0	2	0	1	0	439
15:30	37	205	1	0	28	0	29	0	3	158	27	0	0	0	1	0	489
15:45	43	178	4	0	27	0	34	0	2	138	23	0	1	0	0	0	450
Total	147	758	5	0	114	0	135	0	9	578	101	0	3	0	4	0	1854
16:00	47	225	2	0	17	0	33	0	1	132	21	0	1	0	1	0	480
16:15	42	203	1	0	23	0	41	0	4	126	29	0	1	1	0	0	471
16:30	49	245	2	0	23	0	37	0	3	144	30	0	2	0	1	0	536
16:45	47	220	2	0	25	1	41	0	6	133	19	0	3	1	0	0	498
Total	185	893	7	0	88	1	152	0	14	535	99	0	7	2	2	0	1985
17:00	55	220	5	0	27	1	30	0	1	139	25	0	2	0	0	0	505
17:15	55	202	3	0	30	1	27	0	4	126	28	0	1	1	0	0	478
17:30	56	210	1	0	24	3	48	0	2	151	34	0	3	0	1	0	533
17:45	33	148	1	0	21	0	38	0	2	149	23	0	1	2	0	0	418
Total	199	780	10	0	102	5	143	0	9	565	110	0	7	3	1	0	1934
Grand Total	1165	4545	39	0	722	9	945	0	61	4947	895	1	31	11	29	0	13400
Apprch %	20.3	79.1	0.7	0	43.1	0.5	56.4	0	1	83.8	15.2	0	43.7	15.5	40.8	0	
Total %	8.7	33.9	0.3	0	5.4	0.1	7.1	0	0.5	36.9	6.7	0	0.2	0.1	0.2	0	



MINNESOTA DEPT OF TRANSPORTATION

TRAFFIC DATA COLLECTION - METRO

TH-41 at Hazeltine Blvd.
 Ref.Pt.: 005.200
 Data by: Westwood Professional Services
 TURN MOVEMENT COUNT

File Name : TH-41 at Hazeltine Blvd 2008
 Site Code : 20052501
 Start Date : 10/1/2008
 Page No : 2

Start Time	TH-41 Southbound					Hazeltine Blvd. Westbound					TH-41 Northbound					Hazeltine Blvd. Eastbound					Int. Total
	Left	Thru	Right	Peds	App. Total	Left	Thru	Right	Peds	App. Total	Left	Thru	Right	Peds	App. Total	Left	Thru	Right	Peds	App. Total	
Peak Hour Analysis From 06:00 to 08:45 - Peak 1 of 1																					
Peak Hour for Entire Intersection Begins at 07:15																					
07:15	22	81	0	0	103	2	0	17	0	19	0	213	10	1	224	1	0	0	0	1	347
07:30	11	90	1	0	102	5	0	15	0	20	0	282	32	0	314	1	1	1	0	3	439
07:45	35	99	0	0	134	8	0	19	0	27	0	176	22	0	198	2	0	0	0	2	361
08:00	39	84	1	0	124	19	0	18	0	37	3	154	27	0	184	2	0	2	0	4	349
Total Volume	107	354	2	0	463	34	0	69	0	103	3	825	91	1	920	6	1	3	0	10	1496
% App. Total	23.1	76.5	0.4	0		33	0	67	0		0.3	89.7	9.9	0.1		60	10	30	0		
PHF	.686	.894	.500	.000	.864	.447	.000	.908	.000	.696	.250	.731	.711	.250	.732	.750	.250	.375	.000	.625	.852

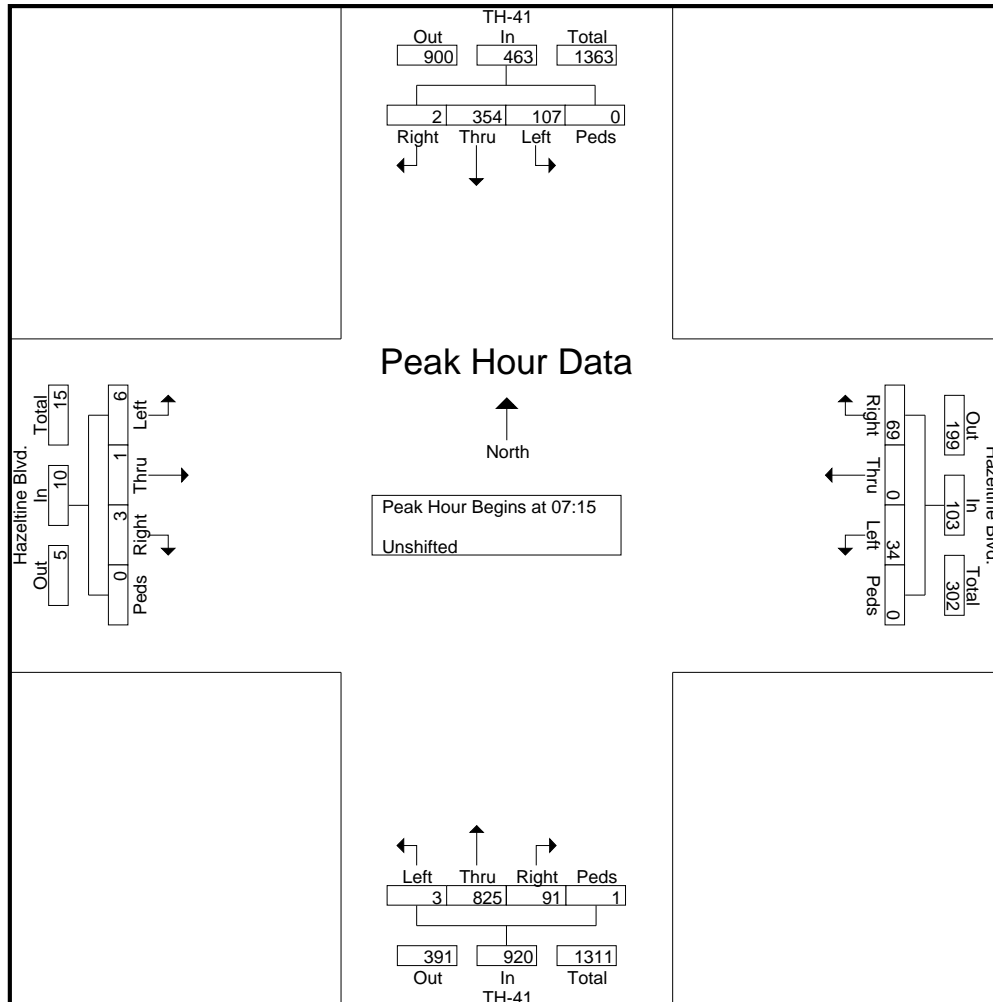



MINNESOTA DEPT OF TRANSPORTATION

TRAFFIC DATA COLLECTION - METRO

TH-41 at Hazeltine Blvd.
 Ref.Pt.: 005.200
 Data by: Westwood Professional Services
 TURN MOVEMENT COUNT

File Name : TH-41 at Hazeltine Blvd 2008
 Site Code : 20052501
 Start Date : 10/1/2008
 Page No : 3

Start Time	TH-41 Southbound					Hazeltine Blvd. Westbound					TH-41 Northbound					Hazeltine Blvd. Eastbound					Int. Total
	Left	Thru	Right	Peds	App. Total	Left	Thru	Right	Peds	App. Total	Left	Thru	Right	Peds	App. Total	Left	Thru	Right	Peds	App. Total	
16:30	49	245	2	0	296	23	0	37	0	60	3	144	30	0	177	2	0	1	0	3	536
16:45	47	220	2	0	269	25	1	41	0	67	6	133	19	0	158	3	1	0	0	4	498
17:00	55	220	5	0	280	27	1	30	0	58	1	139	25	0	165	2	0	0	0	2	505
17:15	55	202	3	0	260	30	1	27	0	58	4	126	28	0	158	1	1	0	0	2	478
Total Volume	206	887	12	0	1105	105	3	135	0	243	14	542	102	0	658	8	2	1	0	11	2017
% App. Total	18.6	80.3	1.1	0		43.2	1.2	55.6	0		2.1	82.4	15.5	0		72.7	18.2	9.1	0		
PHF	.936	.905	.600	.000	.933	.875	.750	.823	.000	.907	.583	.941	.850	.000	.929	.667	.500	.250	.000	.688	.941

Peak Hour Analysis From 15:00 to 17:45 - Peak 1 of 1

Peak Hour for Entire Intersection Begins at 16:30

