



MINNESOTA DEPT OF TRANSPORTATION

TRAFFIC DATA COLLECTION - METRO

MN-51 / SNELLING AVE. AT W Co.Rd.C2
 REF.PT.: 008.854
 DATA COLLECTED BY TDI
 TURN MOVEMENT COUNT

File Name : TH-51 AT Co Rd C2 2007
 Site Code : 01987313
 Start Date : 5/24/2007
 Page No : 1

Groups Printed- Unshifted

Start Time	MN-51 / SNELLING AVE. Southbound				Co.Rd.C2 Westbound				MN-51 / SNELLING AVE. Northbound				Co.Rd.C2 Eastbound				Int. Total
	Left	Thru	Right	Peds	Left	Thru	Right	Peds	Left	Thru	Right	Peds	Left	Thru	Right	Peds	
06:00	6	114	4	0	7	0	2	0	0	49	0	0	4	0	3	0	189
06:15	10	197	12	0	3	2	0	0	0	56	1	0	3	0	4	0	288
06:30	10	289	23	0	2	3	2	0	2	73	2	0	4	3	1	0	414
06:45	20	328	28	0	10	7	7	0	6	101	1	0	3	4	2	0	517
Total	46	928	67	0	22	12	11	0	8	279	4	0	14	7	10	0	1408
07:00	18	382	28	0	12	5	3	0	5	108	5	0	8	1	5	0	580
07:15	21	431	19	0	15	7	8	0	3	151	4	0	2	1	4	0	666
07:30	21	464	46	0	8	10	6	0	1	185	7	0	7	2	8	0	765
07:45	30	458	44	0	9	14	6	0	6	214	5	1	8	7	9	0	811
Total	90	1735	137	0	44	36	23	0	15	658	21	1	25	11	26	0	2822
08:00	28	420	50	0	12	19	4	0	3	166	4	0	13	6	8	0	733
08:15	29	407	46	0	11	14	7	0	7	146	5	0	13	3	11	0	699
08:30	30	322	36	0	12	18	4	0	5	121	4	0	17	5	8	0	582
08:45	20	277	39	0	17	20	6	0	15	154	4	0	9	8	10	0	579
Total	107	1426	171	0	52	71	21	0	30	587	17	0	52	22	37	0	2593
*** BREAK ***																	
15:00	13	199	16	0	13	10	15	0	7	281	9	0	42	6	7	0	618
15:15	8	260	15	0	11	6	15	0	9	377	10	0	43	9	8	0	771
15:30	10	274	17	0	7	8	36	0	6	368	8	0	46	18	9	0	807
15:45	13	265	18	0	6	14	27	0	3	459	10	0	41	8	4	0	868
Total	44	998	66	0	37	38	93	0	25	1485	37	0	172	41	28	0	3064
16:00	6	263	22	0	11	10	61	0	8	471	13	0	48	20	8	0	941
16:15	13	276	31	0	6	13	41	0	9	443	10	0	48	18	18	0	926
16:30	12	313	32	0	10	10	51	1	8	502	7	0	73	31	9	0	1059
16:45	11	285	20	0	14	12	44	0	6	494	14	0	67	19	13	0	999
Total	42	1137	105	0	41	45	197	1	31	1910	44	0	236	88	48	0	3925
17:00	15	315	28	0	10	19	54	0	11	512	13	0	83	15	9	0	1084
17:15	15	313	30	0	8	14	37	0	10	485	15	0	77	33	11	0	1048
17:30	11	334	27	0	7	16	26	0	6	468	13	0	76	30	10	0	1024
17:45	13	259	24	0	8	12	24	0	10	432	17	0	57	17	10	0	883
Total	54	1221	109	0	33	61	141	0	37	1897	58	0	293	95	40	0	4039
Grand Total	383	7445	655	0	229	263	486	1	146	6816	181	1	792	264	189	0	17851
Apprch %	4.5	87.8	7.7	0	23.4	26.9	49.6	0.1	2	95.4	2.5	0	63.6	21.2	15.2	0	
Total %	2.1	41.7	3.7	0	1.3	1.5	2.7	0	0.8	38.2	1	0	4.4	1.5	1.1	0	



MINNESOTA DEPT OF TRANSPORTATION

TRAFFIC DATA COLLECTION - METRO

MN-51 / SNELLING AVE. AT W Co.Rd.C2
 REF.PT.: 008.854
 DATA COLLECTED BY TDI
 TURN MOVEMENT COUNT

File Name : TH-51 AT Co Rd C2 2007
 Site Code : 01987313
 Start Date : 5/24/2007
 Page No : 2

Start Time	MN-51 / SNELLING AVE. Southbound					Co.Rd.C2 Westbound					MN-51 / SNELLING AVE. Northbound					Co.Rd.C2 Eastbound					Int. Total
	Left	Thru	Right	Peds	App. Total	Left	Thru	Right	Peds	App. Total	Left	Thru	Right	Peds	App. Total	Left	Thru	Right	Peds	App. Total	
Peak Hour Analysis From 06:00 to 08:45 - Peak 1 of 1																					
Peak Hour for Entire Intersection Begins at 07:30																					
07:30	21	464	46	0	531	8	10	6	0	24	1	185	7	0	193	7	2	8	0	17	765
07:45	30	458	44	0	532	9	14	6	0	29	6	214	5	1	226	8	7	9	0	24	811
08:00	28	420	50	0	498	12	19	4	0	35	3	166	4	0	173	13	6	8	0	27	733
08:15	29	407	46	0	482	11	14	7	0	32	7	146	5	0	158	13	3	11	0	27	699
Total Volume	108	1749	186	0	2043	40	57	23	0	120	17	711	21	1	750	41	18	36	0	95	3008
% App. Total	5.3	85.6	9.1	0		33.3	47.5	19.2	0		2.3	94.8	2.8	0.1		43.2	18.9	37.9	0		
PHF	.900	.942	.930	.000	.960	.833	.750	.821	.000	.857	.607	.831	.750	.250	.830	.788	.643	.818	.000	.880	.927

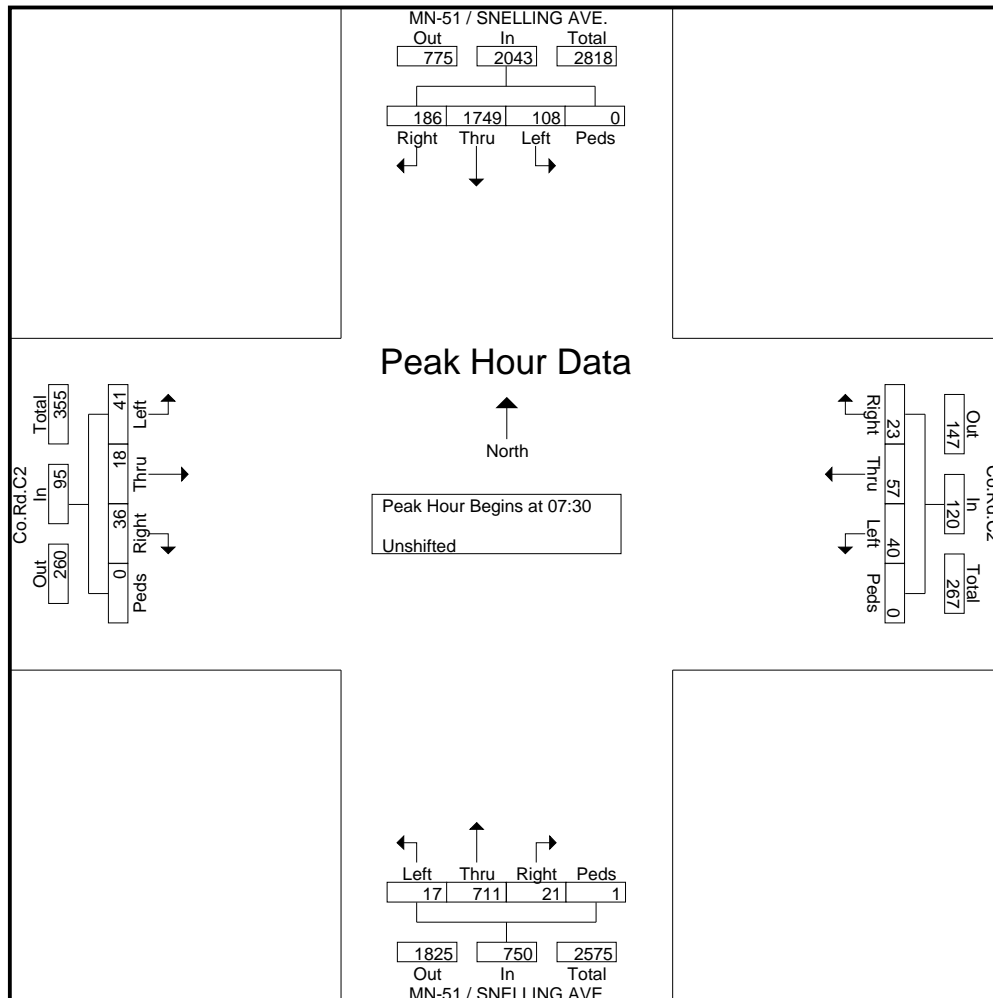



MINNESOTA DEPT OF TRANSPORTATION

TRAFFIC DATA COLLECTION - METRO

MN-51 / SNELLING AVE. AT W Co.Rd.C2
 REF.PT.: 008.854
 DATA COLLECTED BY TDI
 TURN MOVEMENT COUNT

File Name : TH-51 AT Co Rd C2 2007
 Site Code : 01987313
 Start Date : 5/24/2007
 Page No : 3

Start Time	MN-51 / SNELLING AVE. Southbound					Co.Rd.C2 Westbound					MN-51 / SNELLING AVE. Northbound					Co.Rd.C2 Eastbound					Int. Total
	Left	Thru	Right	Peds	App. Total	Left	Thru	Right	Peds	App. Total	Left	Thru	Right	Peds	App. Total	Left	Thru	Right	Peds	App. Total	
Peak Hour Analysis From 15:00 to 17:45 - Peak 1 of 1																					
Peak Hour for Entire Intersection Begins at 16:30																					
16:30	12	313	32	0	357	10	10	51	1	72	8	502	7	0	517	73	31	9	0	113	1059
16:45	11	285	20	0	316	14	12	44	0	70	6	494	14	0	514	67	19	13	0	99	999
17:00	15	315	28	0	358	10	19	54	0	83	11	512	13	0	536	83	15	9	0	107	1084
17:15	15	313	30	0	358	8	14	37	0	59	10	485	15	0	510	77	33	11	0	121	1048
Total Volume	53	1226	110	0	1389	42	55	186	1	284	35	1993	49	0	2077	300	98	42	0	440	4190
% App. Total	3.8	88.3	7.9	0		14.8	19.4	65.5	0.4		1.7	96	2.4	0		68.2	22.3	9.5	0		
PHF	.883	.973	.859	.000	.970	.750	.724	.861	.250	.855	.795	.973	.817	.000	.969	.904	.742	.808	.000	.909	.966

