

# Alliant Engineering Inc Minneapolis, MN 55415

Vicksburg Lane at 32nd Ave N  
Ref.Pt.:  
Alliant Engineering Inc  
TURN MOVEMENT COUNT

File Name : 40\_Vicksburg Ln at 32nd Ave\_012511  
Site Code : 00000040  
Start Date : 1/25/2011  
Page No : 1

### Groups Printed- Unshifted - Bank 1

Start Time	Vicksburg Lane Southbound				32nd Ave N Westbound				Vicksburg Lane Northbound				mall entrance Eastbound				Int. Total
	Left	Thru	Rght	Peds	Left	Thru	Rght	Peds	Left	Thru	Rght	Peds	Left	Thru	Rght	Peds	
06:00	11	27	3	0	2	0	5	0	1	20	4	0	1	0	1	0	75
06:15	13	36	3	0	2	0	9	0	3	27	2	0	2	0	0	0	97
06:30	17	50	15	0	6	0	7	0	5	31	8	0	4	0	7	0	150
06:45	17	81	10	0	5	0	14	0	5	85	0	0	5	1	6	0	229
Total	58	194	31	0	15	0	35	0	14	163	14	0	12	1	14	0	551
07:00	12	106	15	0	0	2	13	0	2	68	1	0	1	2	6	0	228
07:15	11	145	22	0	3	0	9	0	4	49	0	0	6	2	10	0	261
07:30	6	167	18	0	1	0	1	0	8	65	2	0	6	0	9	0	283
07:45	11	217	34	0	0	0	4	0	11	74	4	0	10	2	17	0	384
Total	40	635	89	0	4	2	27	0	25	256	7	0	23	6	42	0	1156
08:00	16	186	12	0	0	1	1	0	9	87	10	0	12	1	7	0	342
08:15	15	95	17	0	2	0	6	0	5	64	4	0	11	3	7	0	229
08:30	15	81	22	0	3	1	4	0	4	49	6	0	14	1	8	0	208
08:45	9	114	27	0	2	1	7	0	9	59	1	0	12	0	5	0	246
Total	55	476	78	0	7	3	18	0	27	259	21	0	49	5	27	0	1025
09:00	27	64	24	0	1	0	3	0	4	71	23	0	19	0	8	0	244
09:15	10	50	31	0	2	0	14	0	11	53	8	0	16	3	10	0	208
*** BREAK ***																	
Total	37	114	55	0	3	0	17	0	15	124	31	0	35	3	18	0	452
*** BREAK ***																	
10:30	6	46	31	0	2	0	8	0	8	49	2	0	24	1	9	0	186
10:45	10	51	36	0	0	1	7	0	20	48	4	0	36	1	11	0	225
Total	16	97	67	0	2	1	15	0	28	97	6	0	60	2	20	0	411
11:00	8	46	43	0	5	1	6	0	23	58	3	0	38	2	10	0	243
11:15	16	68	46	0	7	3	16	0	17	68	0	0	37	2	15	0	295
11:30	13	67	68	0	6	1	14	0	36	101	5	0	39	4	27	0	381
11:45	9	75	81	0	2	1	8	0	25	77	2	0	57	5	29	0	371
Total	46	256	238	0	20	6	44	0	101	304	10	0	171	13	81	0	1290
12:00	10	57	67	0	0	0	5	0	38	84	5	0	56	3	31	0	356
12:15	14	58	92	0	3	1	12	0	21	64	1	0	62	1	23	0	352
12:30	11	74	59	0	0	1	8	0	18	80	5	0	61	4	30	0	351
12:45	14	63	59	0	0	2	6	0	11	62	1	0	67	0	27	0	312
Total	49	252	277	0	3	4	31	0	88	290	12	0	246	8	111	0	1371
13:00	10	79	58	0	1	2	7	0	18	60	3	0	61	2	20	0	321
13:15	13	54	48	0	4	1	4	0	32	64	6	0	40	5	25	0	296
*** BREAK ***																	
Total	23	133	106	0	5	3	11	0	50	124	9	0	101	7	45	0	617
*** BREAK ***																	
14:30	2	79	45	0	3	1	12	0	13	64	2	0	42	0	15	0	278
14:45	10	72	39	0	2	1	3	0	18	69	2	0	47	1	16	1	281
Total	12	151	84	0	5	2	15	0	31	133	4	0	89	1	31	1	559
15:00	3	94	38	0	2	0	10	0	11	75	2	0	44	0	18	0	297
15:15	9	73	41	0	2	2	11	0	22	123	1	0	49	1	25	0	359
15:30	10	60	33	0	3	1	14	0	13	126	11	0	40	1	4	0	316
15:45	10	94	48	0	6	3	5	0	24	148	2	0	50	3	14	0	407
Total	32	321	160	0	13	6	40	0	70	472	16	0	183	5	61	0	1379

# Alliant Engineering Inc Minneapolis, MN 55415

Vicksburg Lane at 32nd Ave N  
Ref.Pt.:  
Alliant Engineering Inc  
TURN MOVEMENT COUNT

File Name : 40\_Vicksburg Ln at 32nd Ave\_012511  
Site Code : 00000040  
Start Date : 1/25/2011  
Page No : 2

### Groups Printed- Unshifted - Bank 1

Start Time	Vicksburg Lane Southbound				32nd Ave N Westbound				Vicksburg Lane Northbound				mall entrance Eastbound				Int. Total
	Left	Thru	Rght	Peds	Left	Thru	Rght	Peds	Left	Thru	Rght	Peds	Left	Thru	Rght	Peds	
16:00	9	79	32	0	3	2	15	0	15	143	3	0	44	0	19	0	364
16:15	17	110	31	0	3	1	5	0	22	168	7	0	40	2	11	0	417
16:30	16	77	35	0	2	3	18	0	18	155	8	0	46	1	18	0	397
16:45	5	104	42	0	6	0	11	0	19	233	5	1	43	0	13	0	482
Total	47	370	140	0	14	6	49	0	74	699	23	1	173	3	61	0	1660
17:00	3	119	44	0	5	1	17	0	24	239	2	0	41	2	27	0	524
17:15	3	92	43	0	5	2	8	0	16	185	0	0	49	2	18	0	423
17:30	5	98	61	0	3	1	5	0	29	205	1	0	64	1	27	0	500
17:45	7	102	57	0	4	1	9	0	20	135	1	0	56	1	21	0	414
Total	18	411	205	0	17	5	39	0	89	764	4	0	210	6	93	0	1861
Grand Total	433	3410	1530	0	108	38	341	0	612	3685	157	1	1352	60	604	1	12332
Apprch %	8.1	63.5	28.5	0	22.2	7.8	70	0	13.7	82.7	3.5	0	67	3	29.9	0	
Total %	3.5	27.7	12.4	0	0.9	0.3	2.8	0	5	29.9	1.3	0	11	0.5	4.9	0	
Unshifted	310	3321	1509	0	61	35	249	0	608	3611	67	1	1334	56	594	1	11757
% Unshifted	71.6	97.4	98.6	0	56.5	92.1	73	0	99.3	98	42.7	100	98.7	93.3	98.3	100	95.3
Bank 1	123	89	21	0	47	3	92	0	4	74	90	0	18	4	10	0	575
% Bank 1	28.4	2.6	1.4	0	43.5	7.9	27	0	0.7	2	57.3	0	1.3	6.7	1.7	0	4.7

# Alliant Engineering Inc Minneapolis, MN 55415

Vicksburg Lane at 32nd Ave N  
Ref.Pt.:  
Alliant Engineering Inc  
TURN MOVEMENT COUNT

File Name : 40\_Vicksburg Ln at 32nd Ave\_012511  
Site Code : 00000040  
Start Date : 1/25/2011  
Page No : 3

Start Time	Vicksburg Lane Southbound					32nd Ave N Westbound					Vicksburg Lane Northbound					mall entrance Eastbound					Int. Total
	Left	Thru	Rght	Peds	App. Total	Left	Thru	Rght	Peds	App. Total	Left	Thru	Rght	Peds	App. Total	Left	Thru	Rght	Peds	App. Total	
Peak Hour Analysis From 06:00 to 09:15 - Peak 1 of 1																					
Peak Hour for Entire Intersection Begins at 07:15																					
07:15	11	145	22	0	178	3	0	9	0	12	4	49	0	0	53	6	2	10	0	18	261
07:30	6	167	18	0	191	1	0	1	0	2	8	65	2	0	75	6	0	9	0	15	283
07:45	11	217	34	0	262	0	0	4	0	4	11	74	4	0	89	10	2	17	0	29	384
08:00	16	186	12	0	214	0	1	1	0	2	9	87	10	0	106	12	1	7	0	20	342
Total Volume	44	715	86	0	845	4	1	15	0	20	32	275	16	0	323	34	5	43	0	82	1270
% App. Total	5.2	84.6	10.2	0		20	5	75	0		9.9	85.1	5	0		41.5	6.1	52.4	0		
PHF	.688	.824	.632	.000	.806	.333	.250	.417	.000	.417	.727	.790	.400	.000	.762	.708	.625	.632	.000	.707	.827

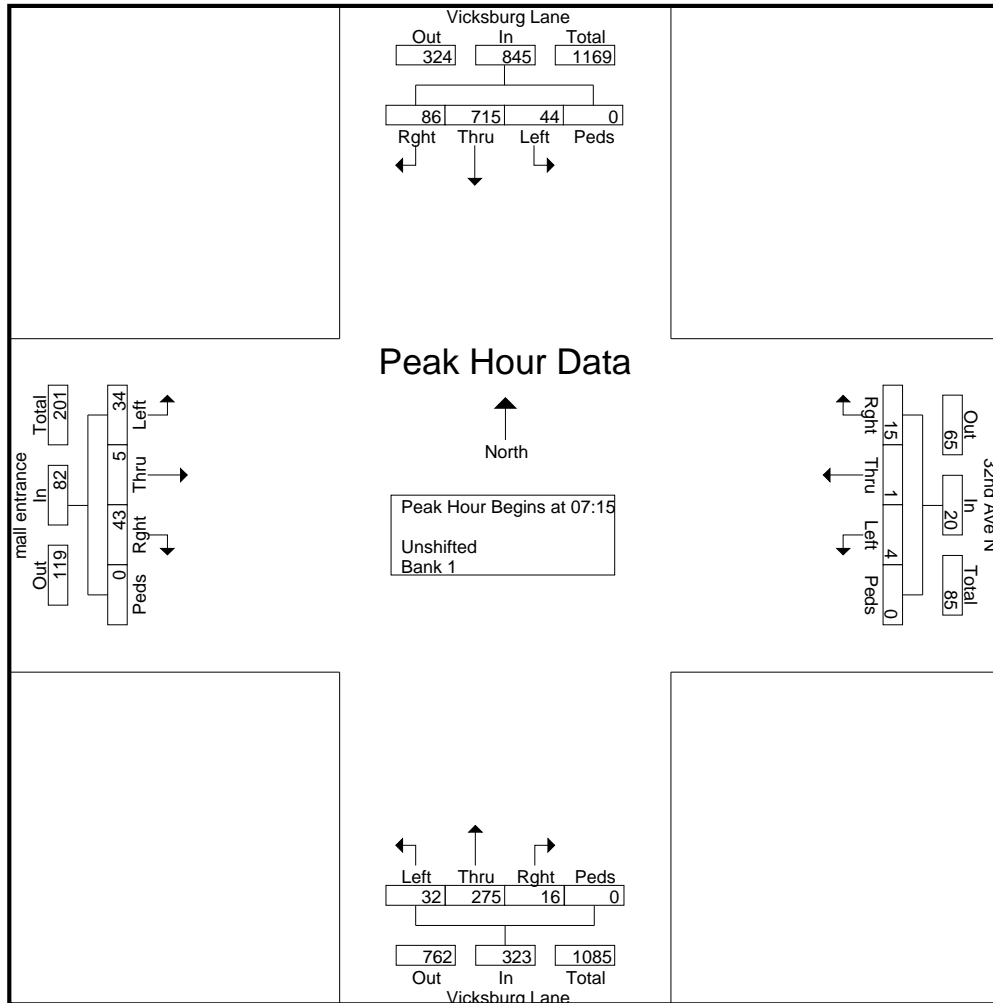

# Alliant Engineering Inc Minneapolis, MN 55415

Vicksburg Lane at 32nd Ave N  
Ref.Pt.:  
Alliant Engineering Inc  
TURN MOVEMENT COUNT

File Name : 40\_Vicksburg Ln at 32nd Ave\_012511  
Site Code : 00000040  
Start Date : 1/25/2011  
Page No : 4

Start Time	Vicksburg Lane Southbound					32nd Ave N Westbound					Vicksburg Lane Northbound					mall entrance Eastbound					Int. Total
	Left	Thru	Rght	Peds	App. Total	Left	Thru	Rght	Peds	App. Total	Left	Thru	Rght	Peds	App. Total	Left	Thru	Rght	Peds	App. Total	
Peak Hour Analysis From 14:30 to 17:45 - Peak 1 of 1																					
Peak Hour for Entire Intersection Begins at 16:45																					
16:45	5	104	42	0	151	6	0	11	0	17	19	233	5	1	258	43	0	13	0	56	482
17:00	3	119	44	0	166	5	1	17	0	23	24	239	2	0	265	41	2	27	0	70	524
17:15	3	92	43	0	138	5	2	8	0	15	16	185	0	0	201	49	2	18	0	69	423
17:30	5	98	61	0	164	3	1	5	0	9	29	205	1	0	235	64	1	27	0	92	500
Total Volume	16	413	190	0	619	19	4	41	0	64	88	862	8	1	959	197	5	85	0	287	1929
% App. Total	2.6	66.7	30.7	0		29.7	6.2	64.1	0		9.2	89.9	0.8	0.1		68.6	1.7	29.6	0		
PHF	.800	.868	.779	.000	.932	.792	.500	.603	.000	.696	.759	.902	.400	.250	.905	.770	.625	.787	.000	.780	.920

