

MN Dept of Transportation

TRAFFIC DATA COLLECTION - Metro

TH-55 at Larch Lane N
 Ref.Pt. 182.068
 video JJ
 TURN MOVEMENT COUNT

File Name : TH-55 at Larch Lane N 2015
 Site Code :
 Start Date : 8/27/2015
 Page No : 1

Groups Printed- Cars +

Start Time	TH-55 Southbound				Larch Lane Westbound				TH-55 Northbound				Larch Lane Eastbound				Int. Total
	Left	Thru	Right	Peds	Left	Thru	Right	Peds	Left	Thru	Right	Peds	Left	Thru	Right	Peds	
06:00	0	261	2	0	1	0	0	0	3	136	0	0	3	2	4	0	412
06:15	1	307	3	0	0	0	1	0	0	213	0	0	1	0	1	0	527
06:30	0	421	2	0	1	0	1	0	1	269	0	0	2	0	6	0	703
06:45	0	516	12	0	0	0	0	0	12	322	0	0	1	0	6	0	869
Total	1	1505	19	0	2	0	2	0	16	940	0	0	7	2	17	0	2511
07:00	1	559	15	0	0	0	0	0	4	286	0	0	3	0	6	0	874
07:15	0	604	12	0	1	0	2	0	17	365	0	0	8	0	12	0	1021
07:30	0	663	20	0	2	0	2	0	14	329	0	0	6	0	10	0	1046
07:45	1	673	13	0	0	0	1	0	19	414	2	0	4	0	10	0	1137
Total	2	2499	60	0	3	0	5	0	54	1394	2	0	21	0	38	0	4078
08:00	2	563	16	0	0	0	1	0	8	389	0	0	8	0	8	0	995
08:15	2	617	17	0	0	0	1	0	6	383	1	0	10	0	4	0	1041
08:30	1	505	10	0	0	0	1	0	5	329	0	0	10	0	5	0	866
08:45	1	479	12	0	0	0	1	0	4	319	0	0	7	0	11	0	834
Total	6	2164	55	0	0	0	4	0	23	1420	1	0	35	0	28	0	3736
*****BREAK*****																	
15:00	3	452	9	0	1	0	1	0	5	400	0	0	4	0	7	0	882
15:15	0	398	5	0	0	0	1	0	3	469	2	0	2	0	4	0	884
15:30	2	586	7	0	0	0	0	0	4	423	0	0	2	0	4	0	1028
15:45	4	366	4	0	0	0	0	0	5	542	1	0	4	1	3	0	930
Total	9	1802	25	0	1	0	2	0	17	1834	3	0	12	1	18	0	3724
16:00	3	498	11	0	1	0	0	0	8	537	0	0	10	0	7	0	1075
16:15	1	462	11	0	0	0	1	0	9	564	0	0	12	0	4	0	1064
16:30	1	530	5	0	0	0	0	0	14	625	1	0	12	0	9	0	1197
16:45	0	457	21	0	0	0	0	0	7	491	0	0	10	0	13	0	999
Total	5	1947	48	0	1	0	1	0	38	2217	1	0	44	0	33	0	4335
17:00	2	529	15	0	1	0	2	0	10	569	1	0	8	0	14	0	1151
17:15	0	448	11	0	0	0	0	0	16	493	1	0	12	0	7	0	988
17:30	2	369	12	0	0	0	2	0	22	548	0	0	10	0	12	0	977
17:45	0	347	14	0	0	0	0	0	7	481	2	0	9	0	11	0	871
Total	4	1693	52	0	1	0	4	0	55	2091	4	0	39	0	44	0	3987
Grand Total	27	11610	259	0	8	0	18	0	203	9896	11	0	158	3	178	0	22371
Apprch %	0.2	97.6	2.2	0	30.8	0	69.2	0	2	97.9	0.1	0	46.6	0.9	52.5	0	
Total %	0.1	51.9	1.2	0	0	0	0.1	0	0.9	44.2	0	0	0.7	0	0.8	0	

PM - cars collecting in median waiting to turn.

MN Dept of Transportation

TRAFFIC DATA COLLECTION - Metro

TH-55 at Larch Lane N
 Ref.Pt. 182.068
 video JJ
 TURN MOVEMENT COUNT

File Name : TH-55 at Larch Lane N 2015
 Site Code :
 Start Date : 8/27/2015
 Page No : 2

Start Time	TH-55 Southbound					Larch Lane Westbound					TH-55 Northbound					Larch Lane Eastbound					Int. Total
	Left	Thru	Right	Peds	App. Total	Left	Thru	Right	Peds	App. Total	Left	Thru	Right	Peds	App. Total	Left	Thru	Right	Peds	App. Total	
Peak Hour Analysis From 06:00 to 08:45 - Peak 1 of 1																					
Peak Hour for Entire Intersection Begins at 07:30																					
07:30	0	663	20	0	683	2	0	2	0	4	14	329	0	0	343	6	0	10	0	16	1046
07:45	1	673	13	0	687	0	0	1	0	1	19	414	2	0	435	4	0	10	0	14	1137
08:00	2	563	16	0	581	0	0	1	0	1	8	389	0	0	397	8	0	8	0	16	995
08:15	2	617	17	0	636	0	0	1	0	1	6	383	1	0	390	10	0	4	0	14	1041
Total Volume	5	2516	66	0	2587	2	0	5	0	7	47	1515	3	0	1565	28	0	32	0	60	4219
% App. Total	0.2	97.3	2.6	0		28.6	0	71.4	0		3	96.8	0.2	0		46.7	0	53.3	0		
PHF	.625	.935	.825	.000	.941	.250	.000	.625	.000	.438	.618	.915	.375	.000	.899	.700	.000	.800	.000	.938	.928

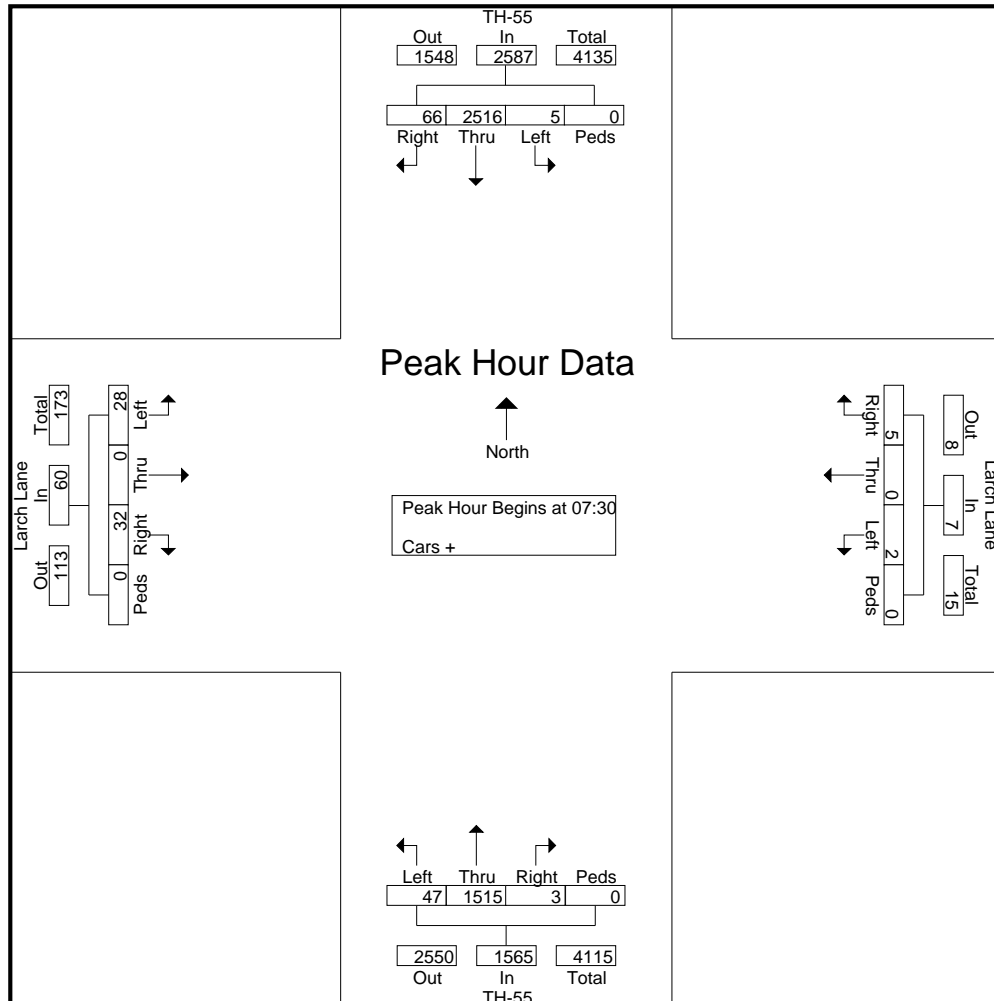

MN Dept of Transportation

TRAFFIC DATA COLLECTION - Metro

TH-55 at Larch Lane N
 Ref.Pt. 182.068
 video JJ
 TURN MOVEMENT COUNT

File Name : TH-55 at Larch Lane N 2015
 Site Code :
 Start Date : 8/27/2015
 Page No : 3

Start Time	TH-55 Southbound					Larch Lane Westbound					TH-55 Northbound					Larch Lane Eastbound					Int. Total
	Left	Thru	Right	Peds	App. Total	Left	Thru	Right	Peds	App. Total	Left	Thru	Right	Peds	App. Total	Left	Thru	Right	Peds	App. Total	
Peak Hour Analysis From 15:00 to 17:45 - Peak 1 of 1																					
Peak Hour for Entire Intersection Begins at 16:15																					
16:15	1	462	11	0	474	0	0	1	0	1	9	564	0	0	573	12	0	4	0	16	1064
16:30	1	530	5	0	536	0	0	0	0	0	14	625	1	0	640	12	0	9	0	21	1197
16:45	0	457	21	0	478	0	0	0	0	0	7	491	0	0	498	10	0	13	0	23	999
17:00	2	529	15	0	546	1	0	2	0	3	10	569	1	0	580	8	0	14	0	22	1151
Total Volume	4	1978	52	0	2034	1	0	3	0	4	40	2249	2	0	2291	42	0	40	0	82	4411
% App. Total	0.2	97.2	2.6	0		25	0	75	0		1.7	98.2	0.1	0		51.2	0	48.8	0		
PHF	.500	.933	.619	.000	.931	.250	.000	.375	.000	.333	.714	.900	.500	.000	.895	.875	.000	.714	.000	.891	.921

