

Alliant Engineering, Inc.

233 Park Ave Suite 300

Minneapolis, MN 55415

--TRAFFIC DATA--

TH 55 and 100 Single Point Interchange

Ref.Pt.: 8.898

data by : Alliant Inc.

TURN MOVEMENT COUNT

File Name : 425_TH 55 & TH 100

Site Code : 425

Start Date : 2/15/2018

Page No : 1

Groups Printed- Class 1 - Class 2

Start Time	TH 100 From North					TH 55 From East					TH 100 From South					TH 55 From West					Int. Total
	Other	Right	Thru	Left	App. Total	Other	Right	Thru	Left	App. Total	Other	Right	Thru	Left	App. Total	Other	Right	Thru	Left	App. Total	
06:00 AM	0	42	0	14	56	0	5	47	11	63	0	27	0	26	53	0	36	58	23	117	289
06:15 AM	0	65	0	30	95	0	12	47	23	82	0	43	0	49	92	0	50	97	15	162	431
06:30 AM	0	96	0	34	130	0	15	63	29	107	0	40	0	69	109	0	40	113	28	181	527
06:45 AM	0	101	0	43	144	0	22	61	26	109	0	68	0	85	153	0	48	190	46	284	690
Total	0	304	0	121	425	0	54	218	89	361	0	178	0	229	407	0	174	458	112	744	1937
07:00 AM	0	92	0	38	130	0	23	60	26	109	0	83	0	67	150	0	72	268	40	380	769
07:15 AM	0	81	0	50	131	0	24	102	35	161	0	121	0	60	181	0	77	347	39	463	936
07:30 AM	0	56	0	68	124	0	20	113	42	175	0	113	0	101	214	0	78	381	59	518	1031
07:45 AM	0	41	0	73	114	0	27	169	32	228	0	135	0	93	228	0	75	449	69	593	1163
Total	0	270	0	229	499	0	94	444	135	673	0	452	0	321	773	0	302	1445	207	1954	3899
08:00 AM	0	53	0	66	119	0	26	122	44	192	0	158	0	76	234	0	79	446	44	569	1114
08:15 AM	0	71	0	98	169	0	30	105	47	182	0	153	0	125	278	0	78	364	67	509	1138
08:30 AM	0	71	0	60	131	0	39	107	43	189	0	137	0	112	249	0	69	340	44	453	1022
08:45 AM	0	66	0	59	125	0	28	77	37	142	0	102	0	93	195	0	73	253	52	378	840
Total	0	261	0	283	544	0	123	411	171	705	0	550	0	406	956	0	299	1403	207	1909	4114
09:00 AM	0	76	0	46	122	0	26	66	38	130	0	86	0	63	149	0	60	170	49	279	680
09:15 AM	0	90	0	31	121	0	24	53	46	123	0	91	0	56	147	0	58	119	44	221	612
*** BREAK ***																					
Total	0	166	0	77	243	0	50	119	84	253	0	177	0	119	296	0	118	289	93	500	1292
*** BREAK ***																					
10:30 AM	0	63	0	26	89	0	20	60	26	106	0	48	0	52	100	0	76	71	33	180	475
10:45 AM	0	78	0	20	98	0	25	52	49	126	0	61	0	78	139	0	72	91	48	211	574
Total	0	141	0	46	187	0	45	112	75	232	0	109	0	130	239	0	148	162	81	391	1049
11:00 AM	0	63	0	19	82	0	31	64	41	136	0	44	0	80	124	0	72	76	53	201	543
11:15 AM	0	56	0	22	78	0	24	67	51	142	0	49	0	73	122	0	85	100	52	237	579
11:30 AM	0	55	0	15	70	0	23	66	40	129	0	62	0	61	123	0	72	88	52	212	534
11:45 AM	0	61	0	33	94	0	35	87	44	166	0	64	0	66	130	0	76	102	51	229	619
Total	0	235	0	89	324	0	113	284	176	573	0	219	0	280	499	0	305	366	208	879	2275
12:00 PM	0	69	0	19	88	0	50	114	50	214	0	48	0	81	129	0	81	101	50	232	663
12:15 PM	0	63	0	29	92	0	44	69	42	155	0	81	0	75	156	0	76	103	45	224	627
12:30 PM	0	72	0	29	101	0	43	85	57	185	0	68	0	73	141	0	76	117	56	249	676
12:45 PM	0	66	0	42	108	0	22	86	37	145	0	59	0	78	137	0	75	131	70	276	666
Total	0	270	0	119	389	0	159	354	186	699	0	256	0	307	563	0	308	452	221	981	2632
01:00 PM	0	56	0	17	73	0	25	59	55	139	0	65	0	79	144	0	91	125	53	269	625
01:15 PM	0	65	0	24	89	0	23	62	46	131	0	55	0	70	125	0	72	84	54	210	555
*** BREAK ***																					
Total	0	121	0	41	162	0	48	121	101	270	0	120	0	149	269	0	163	209	107	479	1180
*** BREAK ***																					
02:30 PM	0	78	0	34	112	0	66	71	56	193	0	75	0	72	147	0	55	117	79	251	703
02:45 PM	0	90	0	28	118	0	54	79	53	186	0	75	0	87	162	0	69	115	83	267	733
Total	0	168	0	62	230	0	120	150	109	379	0	150	0	159	309	0	124	232	162	518	1436
03:00 PM	0	66	0	32	98	0	91	87	46	224	0	74	0	100	174	0	87	139	69	295	791
03:15 PM	0	64	0	25	89	0	65	102	80	247	0	95	0	98	193	0	97	149	76	322	851
03:30 PM	0	102	0	44	146	0	74	104	87	265	0	75	0	111	186	0	84	195	90	369	966
03:45 PM	0	85	0	34	119	0	53	201	91	345	0	67	0	85	152	0	125	257	86	468	1084
Total	0	317	0	135	452	0	283	494	304	1081	0	311	0	394	705	0	393	740	321	1454	3692
04:00 PM	0	76	0	39	115	0	71	166	90	327	0	65	0	86	151	0	120	236	96	452	1045
04:15 PM	0	87	0	43	130	0	52	204	108	364	0	69	0	116	185	0	129	237	124	490	1169
04:30 PM	0	85	0	36	121	0	68	229	118	415	0	89	0	124	213	0	129	302	88	519	1268

Alliant Engineering, Inc.

233 Park Ave Suite 300

Minneapolis, MN 55415

--TRAFFIC DATA--

TH 55 and 100 Single Point Interchange

Ref.Pt.: 8.898

data by : Alliant Inc.

TURN MOVEMENT COUNT

File Name : 425_TH 55 & TH 100

Site Code : 425_____

Start Date : 2/15/2018

Page No : 2

Groups Printed- Class 1 - Class 2

Start Time	TH 100 From North					TH 55 From East					TH 100 From South					TH 55 From West					Int. Total
	Other	Rght	Thru	Left	App. Total	Other	Rght	Thru	Left	App. Total	Other	Rght	Thru	Left	App. Total	Other	Rght	Thru	Left	App. Total	
04:45 PM	0	87	0	39	126	0	65	276	118	459	0	93	0	105	198	0	163	418	116	697	1480
Total	0	335	0	157	492	0	256	875	434	1565	0	316	0	431	747	0	541	1193	424	2158	4962
05:00 PM	0	60	0	35	95	0	78	263	146	487	0	94	0	104	198	0	126	337	117	580	1360
05:15 PM	0	77	0	46	123	0	87	223	109	419	0	70	0	128	198	0	164	337	105	606	1346
05:30 PM	0	60	0	40	100	0	53	279	111	443	0	88	0	87	175	0	130	352	89	571	1289
05:45 PM	0	65	0	37	102	0	67	165	77	309	0	84	0	75	159	0	109	255	78	442	1012
Total	0	262	0	158	420	0	285	930	443	1658	0	336	0	394	730	0	529	1281	389	2199	5007
Grand Total	0	2850	0	1517	4367	0	1630	4512	2307	8449	0	3174	0	3319	6493	0	3404	8230	2532	14166	33475
Apprch %	0	65.3	0	34.7		0	19.3	53.4	27.3		0	48.9	0	51.1		0	24	58.1	17.9		
Total %	0	8.5	0	4.5	13	0	4.9	13.5	6.9	25.2	0	9.5	0	9.9	19.4	0	10.2	24.6	7.6	42.3	
Class 1	0	2782	0	1459	4241	0	1630	4386	2255	8271	0	3174	0	3150	6324	0	3333	8003	2439	13775	32611
% Class 1	0	97.6	0	96.2	97.1	0	100	97.2	97.7	97.9	0	100	0	94.9	97.4	0	97.9	97.2	96.3	97.2	97.4
Class 2	0	68	0	58	126	0	0	126	52	178	0	0	0	169	169	0	71	227	93	391	864
% Class 2	0	2.4	0	3.8	2.9	0	0	2.8	2.3	2.1	0	0	0	5.1	2.6	0	2.1	2.8	3.7	2.8	2.6

Alliant Engineering, Inc.

233 Park Ave Suite 300

Minneapolis, MN 55415

--TRAFFIC DATA--

TH 55 and 100 Single Point Interchange

Ref.Pt.: 8.898

data by : Alliant Inc.

TURN MOVEMENT COUNT

File Name : 425_TH 55 & TH 100

Site Code : 425_____

Start Date : 2/15/2018

Page No : 3

Start Time	TH 100 From North					TH 55 From East					TH 100 From South					TH 55 From West					Int. Total
	Other	Right	Thru	Left	App. Total	Other	Right	Thru	Left	App. Total	Other	Right	Thru	Left	App. Total	Other	Right	Thru	Left	App. Total	
Peak Hour Analysis From 06:00 AM to 11:45 AM - Peak 1 of 1																					
Peak Hour for Entire Intersection Begins at 07:30 AM																					
07:30 AM	0	56	0	68	124	0	20	113	42	175	0	113	0	101	214	0	78	381	59	518	1031
07:45 AM	0	41	0	73	114	0	27	169	32	228	0	135	0	93	228	0	75	449	69	593	1163
08:00 AM	0	53	0	66	119	0	26	122	44	192	0	158	0	76	234	0	79	446	44	569	1114
08:15 AM	0	71	0	98	169	0	30	105	47	182	0	153	0	125	278	0	78	364	67	509	1138
Total Volume	0	221	0	305	526	0	103	509	165	777	0	559	0	395	954	0	310	1640	239	2189	4446
% App. Total	0	.42	0	.58	.778	0	13.3	65.5	21.2	.852	0	58.6	0	41.4	.954	0	14.2	74.9	10.9	.923	.956
PHF	.000	.778	.000	.778	.778	.000	.858	.753	.878	.852	.000	.884	.000	.790	.858	.000	.981	.913	.866	.923	.956

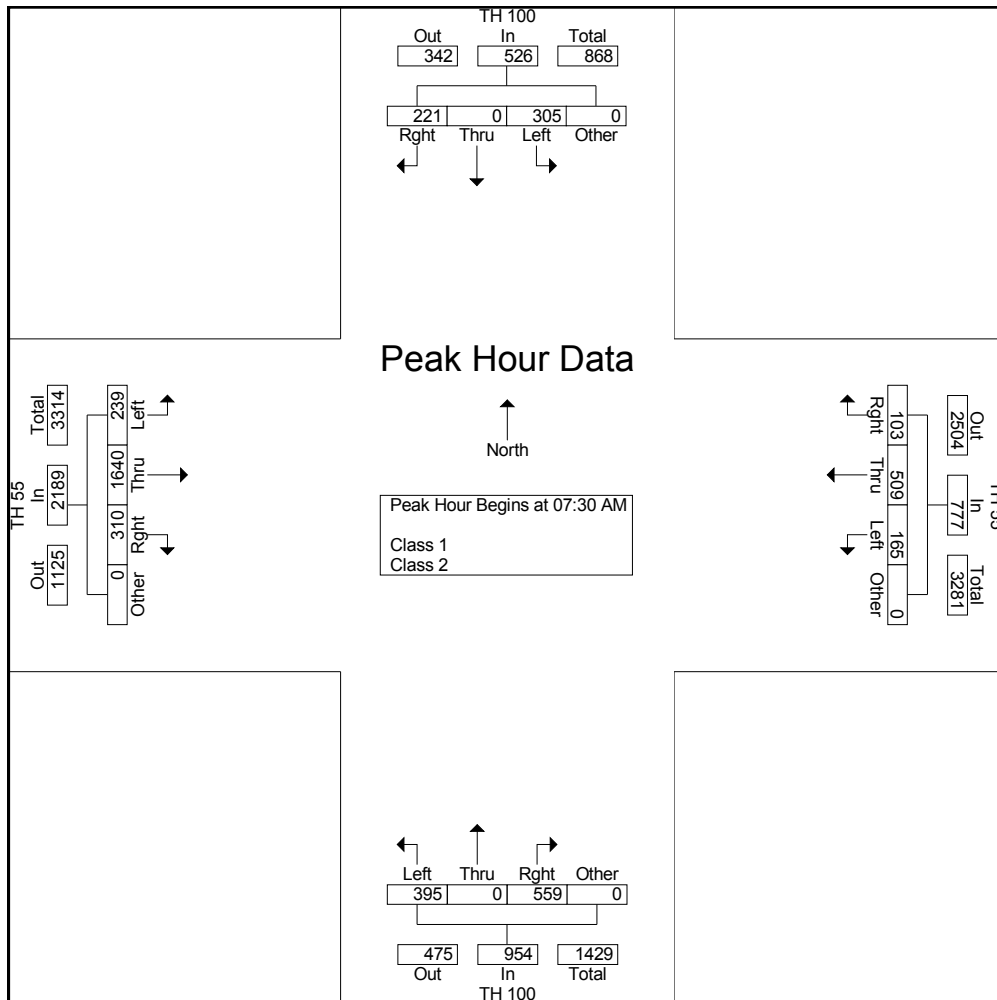

Alliant Engineering, Inc.

233 Park Ave Suite 300
 Minneapolis, MN 55415
 --TRAFFIC DATA--

TH 55 and 100 Single Point Interchange
 Ref.Pt.: 8.898
 data by : Alliant Inc.
 TURN MOVEMENT COUNT

File Name : 425_TH 55 & TH 100
 Site Code : 425_____
 Start Date : 2/15/2018
 Page No : 4

Start Time	TH 100 From North					TH 55 From East					TH 100 From South					TH 55 From West					Int. Total
	Other	Rgh t	Thr u	Left	App. Total	Other	Rgh t	Thr u	Left	App. Total	Other	Rgh t	Thr u	Left	App. Total	Other	Rgh t	Thr u	Left	App. Total	
Peak Hour Analysis From 12:00 PM to 05:45 PM - Peak 1 of 1																					
Peak Hour for Entire Intersection Begins at 04:45 PM																					
04:45 PM	0	87	0	39	126	0	65	276	118	459	0	93	0	105	198	0	163	418	116	697	1480
05:00 PM	0	60	0	35	95	0	78	263	146	487	0	94	0	104	198	0	126	337	117	580	1360
05:15 PM	0	77	0	46	123	0	87	223	109	419	0	70	0	128	198	0	164	337	105	606	1346
05:30 PM	0	60	0	40	100	0	53	279	111	443	0	88	0	87	175	0	130	352	89	571	1289
Total Volume	0	284	0	160	444	0	283	1041	484	1808	0	345	0	424	769	0	583	1444	427	2454	5475
% App. Total	0	64	0	36		0	15.7	57.6	26.8		0	44.9	0	55.1		0	23.8	58.8	17.4		
PHF	.000	.816	.000	.870	.881	.000	.813	.933	.829	.928	.000	.918	.000	.828	.971	.000	.889	.864	.912	.880	.925

