



MINNESOTA DEPT OF TRANSPORTATION

TRAFFIC COLLECTION - METRO

Location: TH-110 AT TH-13
 REF.PT: 000+000.390
 JAMAR#632\DR
 TURN MOVEMENT COUNT

File Name : TH 110 AT TH 13 2006
 Site Code : 00000000
 Start Date : 2/22/2006
 Page No : 1

Groups Printed- Cars & Trucks

Start Time	TH 13 Southbound				TH 110 Westbound				TH 13 Northbound				TH 110 Eastbound				Int. Total
	Right	Thru	Left	Peds	Right	Thru	Left	Peds	Right	Thru	Left	Peds	Right	Thru	Left	Peds	
06:00	2	4	0	0	1	121	12	0	8	3	0	0	0	41	1	0	193
06:15	12	3	1	0	1	164	9	0	7	2	2	0	1	56	1	0	259
06:30	12	4	0	0	0	196	19	0	12	3	2	0	2	74	0	0	324
06:45	16	2	0	0	1	237	28	0	16	4	3	0	8	88	2	0	405
Total	42	13	1	0	3	718	68	0	43	12	7	0	11	259	4	0	1181
07:00	10	4	1	0	2	290	22	0	17	8	3	0	6	97	8	0	468
07:15	15	5	0	0	1	318	15	0	19	16	2	0	10	100	12	0	513
07:30	19	13	2	0	4	308	23	0	29	11	3	0	8	113	2	0	535
07:45	29	13	3	0	6	286	26	0	21	21	2	0	14	131	2	0	554
Total	73	35	6	0	13	1202	86	0	86	56	10	0	38	441	24	0	2070
08:00	19	4	1	0	1	235	30	0	21	12	4	0	10	106	8	0	451
08:15	15	6	1	0	1	193	21	0	13	3	2	0	12	111	7	0	385
08:30	6	13	1	0	1	176	21	0	14	12	3	1	12	116	9	0	385
08:45	9	8	3	0	1	153	17	0	21	17	4	0	3	106	7	0	349
Total	49	31	6	0	4	757	89	0	69	44	13	1	37	439	31	0	1570
15:00	6	12	3	0	1	125	15	0	25	16	2	0	2	182	16	0	405
15:15	11	8	2	0	3	146	12	0	31	12	8	0	4	189	11	0	437
15:30	14	9	4	0	6	121	29	0	38	13	7	0	4	218	11	0	474
15:45	18	15	3	0	3	139	14	0	25	14	7	0	4	194	15	0	451
Total	49	44	12	0	13	531	70	0	119	55	24	0	14	783	53	0	1767
16:00	14	19	3	0	8	140	11	0	42	9	11	0	1	229	10	0	497
16:15	8	6	1	0	6	148	16	0	35	11	11	0	4	282	18	0	546
16:30	12	7	2	0	3	144	10	0	47	35	13	0	7	253	13	0	546
16:45	14	13	1	0	6	147	11	0	39	14	12	0	7	261	21	0	546
Total	48	45	7	0	23	579	48	0	163	69	47	0	19	1025	62	0	2135
17:00	12	20	5	0	7	151	12	0	55	26	16	0	9	234	15	0	562
17:15	12	14	1	0	3	159	12	0	61	20	15	0	6	273	17	0	593
17:30	7	11	1	0	5	136	10	0	43	26	8	0	6	268	27	0	548
17:45	9	13	4	0	6	112	12	0	23	15	6	0	3	241	20	0	464
Total	40	58	11	0	21	558	46	0	182	87	45	0	24	1016	79	0	2167
Grand Total	301	226	43	0	77	4345	407	0	662	323	146	1	143	3963	253	0	10890
Aprch %	52.8	39.6	7.5	0	1.6	90	8.4	0	58.5	28.5	12.9	0.1	3.3	90.9	5.8	0	
Total %	2.8	2.1	0.4	0	0.7	39.9	3.7	0	6.1	3	1.3	0	1.3	36.4	2.3	0	



MINNESOTA DEPT OF TRANSPORTATION

TRAFFIC COLLECTION - METRO

Location: TH-110 AT TH-13
 REF.PT: 000+000.390
 JAMAR#632\DR
 TURN MOVEMENT COUNT

File Name : TH 110 AT TH 13 2006
 Site Code : 00000000
 Start Date : 2/22/2006
 Page No : 2

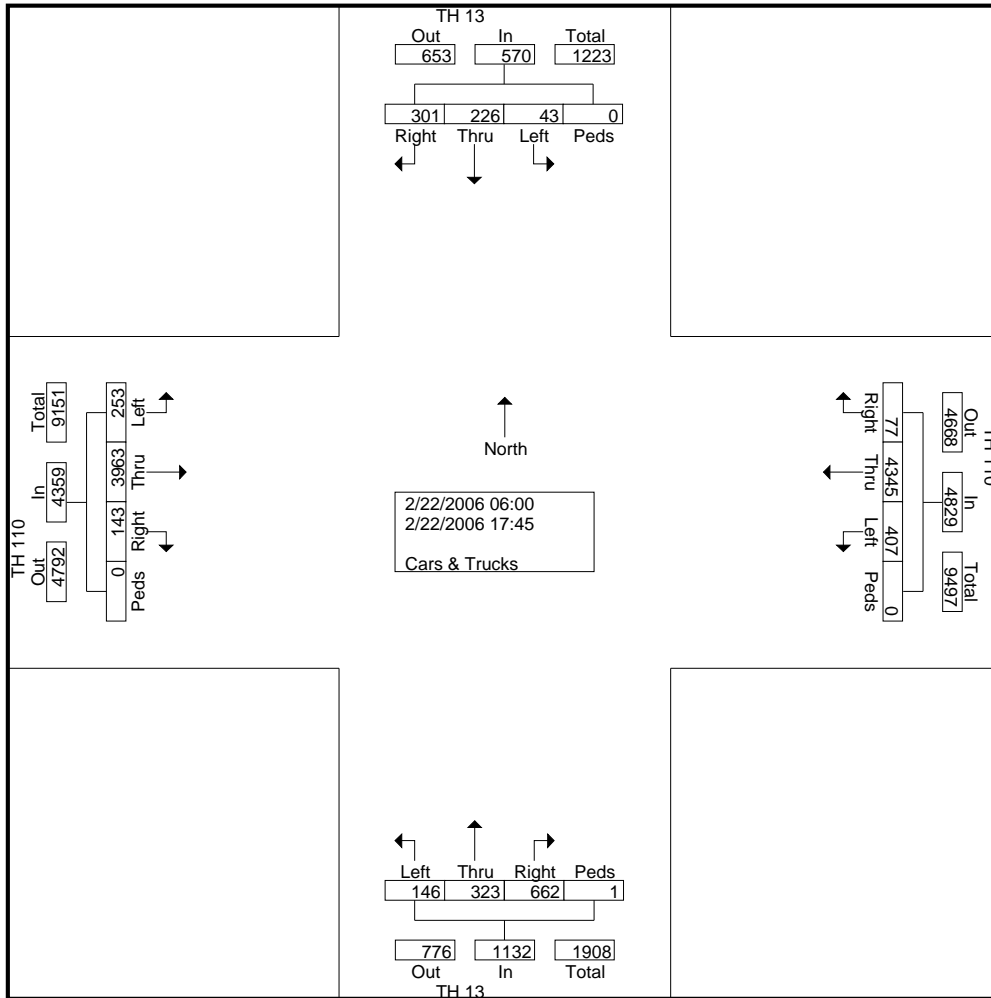



MINNESOTA DEPT OF TRANSPORTATION

TRAFFIC COLLECTION - METRO

Location: TH-110 AT TH-13
 REF.PT: 000+000.390
 JAMAR#632\DR
 TURN MOVEMENT COUNT

File Name : TH 110 AT TH 13 2006
 Site Code : 00000000
 Start Date : 2/22/2006
 Page No : 3

Start Time	TH 13 Southbound					TH 110 Westbound					TH 13 Northbound					TH 110 Eastbound					Int. Total
	Right	Thru	Left	Peds	App. Total	Right	Thru	Left	Peds	App. Total	Right	Thru	Left	Peds	App. Total	Right	Thru	Left	Peds	App. Total	
Peak Hour Analysis From 06:00 to 08:45 - Peak 1 of 1																					
Peak Hour for Entire Intersection Begins at 07:00																					
07:00	10	4	1	0	15	2	290	22	0	314	17	8	3	0	28	6	97	8	0	111	468
07:15	15	5	0	0	20	1	318	15	0	334	19	16	2	0	37	10	100	12	0	122	513
07:30	19	13	2	0	34	4	308	23	0	335	29	11	3	0	43	8	113	2	0	123	535
07:45	29	13	3	0	45	6	286	26	0	318	21	21	2	0	44	14	131	2	0	147	554
Total Volume	73	35	6	0	114	13	1202	86	0	1301	86	56	10	0	152	38	441	24	0	503	2070
% App. Total	64	30.7	5.3	0		1	92.4	6.6	0		56.6	36.8	6.6	0		7.6	87.7	4.8	0		
PHF	.629	.673	.500	.000	.633	.542	.945	.827	.000	.971	.741	.667	.833	.000	.864	.679	.842	.500	.000	.855	.934

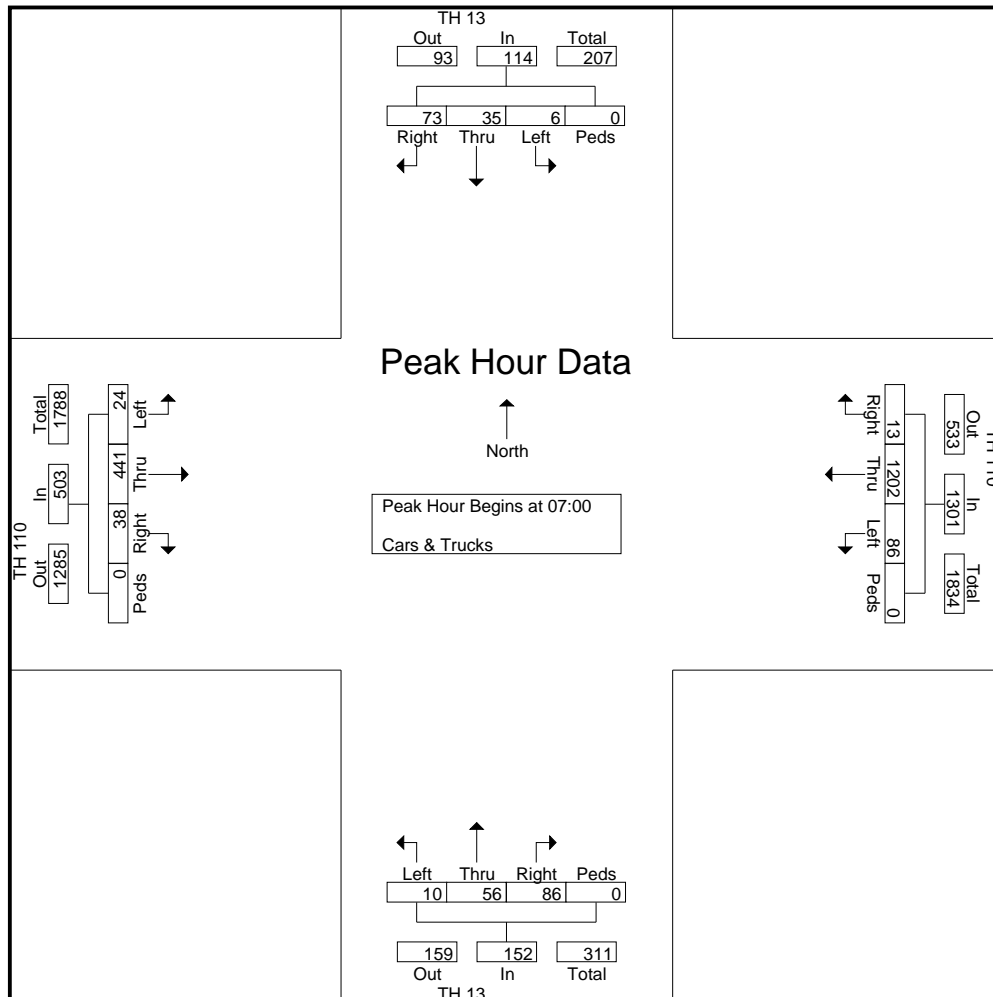



MINNESOTA DEPT OF TRANSPORTATION

TRAFFIC COLLECTION - METRO

Location: TH-110 AT TH-13
 REF.PT: 000+000.390
 JAMAR#632\DR
 TURN MOVEMENT COUNT

File Name : TH 110 AT TH 13 2006
 Site Code : 00000000
 Start Date : 2/22/2006
 Page No : 4

Start Time	TH 13 Southbound					TH 110 Westbound					TH 13 Northbound					TH 110 Eastbound					Int. Total
	Right	Thru	Left	Peds	App. Total	Right	Thru	Left	Peds	App. Total	Right	Thru	Left	Peds	App. Total	Right	Thru	Left	Peds	App. Total	
Peak Hour Analysis From 15:00 to 17:45 - Peak 1 of 1																					
Peak Hour for Entire Intersection Begins at 16:45																					
16:45	14	13	1	0	28	6	147	11	0	164	39	14	12	0	65	7	261	21	0	289	546
17:00	12	20	5	0	37	7	151	12	0	170	55	26	16	0	97	9	234	15	0	258	562
17:15	12	14	1	0	27	3	159	12	0	174	61	20	15	0	96	6	273	17	0	296	593
17:30	7	11	1	0	19	5	136	10	0	151	43	26	8	0	77	6	268	27	0	301	548
Total Volume	45	58	8	0	111	21	593	45	0	659	198	86	51	0	335	28	1036	80	0	1144	2249
% App. Total	40.5	52.3	7.2	0		3.2	90	6.8	0		59.1	25.7	15.2	0		2.4	90.6	7	0		
PHF	.804	.725	.400	.000	.750	.750	.932	.938	.000	.947	.811	.827	.797	.000	.863	.778	.949	.741	.000	.950	.948

