

Alliant Engineering

Minneapolis, MN 55415

--TRAFFIC DATA --

TH-110 at Delaware Ave.
 Ref.Pt.: 002.965
 data by Alliant Engineering
 TURN MOVEMENT COUNT

File Name : 416 - TH 110 and Delaware
 Site Code : 416
 Start Date : 4/9/2015
 Page No : 1

Groups Printed- Cars - Trucks

Start Time	Deleware Ave / CSAH-63 Southbound				TH-110 Westbound				Deleware Ave Northbound				TH-110 Eastbound				Int. Total
	Left	Thru	Rght	Bikes	Left	Thru	Rght	Bikes	Left	Thru	Rght	Bikes	Left	Thru	Rght	Bikes	
06:00	3	6	13	0	10	149	4	0	1	0	1	0	2	52	0	0	241
06:15	11	11	14	0	2	222	6	0	2	8	6	0	4	73	0	0	359
06:30	19	13	20	0	6	293	11	0	10	8	6	0	5	76	4	0	471
06:45	16	20	25	0	3	327	9	0	12	20	13	0	7	127	2	0	581
Total	49	50	72	0	21	991	30	0	25	36	26	0	18	328	6	0	1652
07:00	18	15	28	0	3	341	14	0	12	16	9	0	9	122	2	0	589
07:15	24	30	54	0	11	310	31	0	20	27	11	0	14	147	7	0	686
07:30	32	34	40	0	13	339	20	0	18	30	19	0	15	156	5	0	721
07:45	32	34	32	0	20	268	13	0	13	37	18	0	27	182	7	0	683
Total	106	113	154	0	47	1258	78	0	63	110	57	0	65	607	21	0	2679
08:00	26	33	29	0	15	288	28	0	6	41	20	0	16	180	8	0	690
08:15	26	58	40	2	24	276	24	0	13	59	16	0	34	127	9	0	708
08:30	25	25	38	0	15	278	14	0	16	13	23	0	13	153	9	0	622
08:45	13	12	19	0	13	237	12	0	12	16	10	0	14	152	6	0	516
Total	90	128	126	2	67	1079	78	0	47	129	69	0	77	612	32	0	2536
09:00	11	5	18	0	10	220	15	0	10	19	18	0	8	121	6	0	461
09:15	14	10	18	0	6	168	8	0	6	15	10	0	5	131	4	0	395
*** BREAK ***																	
Total	25	15	36	0	16	388	23	0	16	34	28	0	13	252	10	0	856
*** BREAK ***																	
10:30	3	8	16	0	9	158	12	0	7	6	8	0	4	129	5	0	365
10:45	14	12	11	0	5	140	10	0	5	8	9	0	8	115	2	0	339
Total	17	20	27	0	14	298	22	0	12	14	17	0	12	244	7	0	704
11:00	13	10	12	0	29	143	3	0	13	13	11	0	9	139	7	0	402
11:15	10	10	10	0	8	142	16	0	6	6	9	0	14	135	7	0	373
11:30	17	12	13	0	11	200	14	0	9	8	12	0	10	134	2	0	442
11:45	13	6	10	0	10	151	18	0	7	11	12	0	9	143	8	0	398
Total	53	38	45	0	58	636	51	0	35	38	44	0	42	551	24	0	1615
12:00	15	12	12	0	14	143	18	0	4	13	14	0	7	131	10	0	393
12:15	16	7	13	0	9	172	2	0	7	9	8	0	5	138	8	0	394
12:30	10	7	13	0	13	165	8	0	4	9	7	0	10	147	11	0	404
12:45	14	5	16	0	11	157	7	0	8	12	11	0	10	178	11	0	440
Total	55	31	54	0	47	637	35	0	23	43	40	0	32	594	40	0	1631
13:00	17	18	12	0	6	143	9	0	7	15	4	0	13	136	12	0	392
13:15	9	14	12	0	7	140	6	0	8	11	10	0	16	162	8	0	403
*** BREAK ***																	
Total	26	32	24	0	13	283	15	0	15	26	14	0	29	298	20	0	795
*** BREAK ***																	
14:30	17	15	21	0	15	160	8	0	9	7	15	0	14	223	5	0	509
14:45	17	16	13	0	10	181	32	0	9	17	14	0	25	218	4	0	556
Total	34	31	34	0	25	341	40	0	18	24	29	0	39	441	9	0	1065
15:00	17	21	20	0	14	138	10	0	5	17	10	0	26	192	7	0	477
15:15	19	40	26	0	16	197	13	0	15	25	17	1	16	273	13	0	671
15:30	40	21	31	0	20	210	22	0	9	37	24	0	16	246	12	0	688
15:45	29	31	36	0	15	225	10	0	8	16	12	0	15	308	11	0	716
Total	105	113	113	0	65	770	55	0	37	95	63	1	73	1019	43	0	2552
16:00	15	21	28	0	27	265	15	0	10	27	12	0	34	376	18	0	848
16:15	20	18	24	0	21	322	23	0	8	15	18	0	15	424	18	0	926
16:30	17	22	24	0	40	326	29	0	4	12	16	0	37	381	22	0	930

Alliant Engineering

Minneapolis, MN 55415

--TRAFFIC DATA --

TH-110 at Delaware Ave.
 Ref.Pt.: 002.965
 data by Alliant Engineering
 TURN MOVEMENT COUNT

File Name : 416 - TH 110 and Delaware
 Site Code : 416
 Start Date : 4/9/2015
 Page No : 2

Groups Printed- Cars - Trucks

Start Time	Deleware Ave / CSAH-63 Southbound				TH-110 Westbound				Deleware Ave Northbound				TH-110 Eastbound				Int. Total
	Left	Thru	Rght	Bikes	Left	Thru	Rght	Bikes	Left	Thru	Rght	Bikes	Left	Thru	Rght	Bikes	
16:45	25	30	27	0	31	327	21	0	7	25	22	0	37	473	14	0	1039
Total	77	91	103	0	119	1240	88	0	29	79	68	0	123	1654	72	0	3743
17:00	15	27	17	0	32	321	21	0	9	27	19	0	33	445	21	0	987
17:15	24	37	17	0	26	284	21	0	12	30	17	0	33	411	10	0	922
17:30	16	37	27	0	30	227	19	0	13	19	13	0	23	253	4	0	681
17:45	20	21	16	0	11	231	22	0	13	22	13	0	12	280	9	0	670
Total	75	122	77	0	99	1063	83	0	47	98	62	0	101	1389	44	0	3260
*** BREAK ***																	
Grand Total	712	784	865	2	591	8984	598	0	367	726	517	1	624	7989	328	0	23088
Apprch %	30.1	33.2	36.6	0.1	5.8	88.3	5.9	0	22.8	45.1	32.1	0.1	7	89.4	3.7	0	
Total %	3.1	3.4	3.7	0	2.6	38.9	2.6	0	1.6	3.1	2.2	0	2.7	34.6	1.4	0	
Cars	701	746	852	2	583	8867	587	0	366	701	512	1	604	7857	326	0	22705
% Cars	98.5	95.2	98.5	100	98.6	98.7	98.2	0	99.7	96.6	99	100	96.8	98.3	99.4	0	98.3
Trucks	11	38	13	0	8	117	11	0	1	25	5	0	20	132	2	0	383
% Trucks	1.5	4.8	1.5	0	1.4	1.3	1.8	0	0.3	3.4	1	0	3.2	1.7	0.6	0	1.7

Alliant Engineering

Minneapolis, MN 55415

--TRAFFIC DATA --

TH-110 at Delaware Ave.
 Ref.Pt.: 002.965
 data by Alliant Engineering
 TURN MOVEMENT COUNT

File Name : 416 - TH 110 and Delaware
 Site Code : 416
 Start Date : 4/9/2015
 Page No : 3

Start Time	Deleware Ave / CSAH-63 Southbound					TH-110 Westbound					Deleware Ave Northbound					TH-110 Eastbound					Int. Total
	Left	Thru	Right	Bikes	App. Total	Left	Thru	Right	Bikes	App. Total	Left	Thru	Right	Bikes	App. Total	Left	Thru	Right	Bikes	App. Total	
Peak Hour Analysis From 06:00 to 11:45 - Peak 1 of 1																					
Peak Hour for Entire Intersection Begins at 07:30																					
07:30	32	34	40	0	106	13	339	20	0	372	18	30	19	0	67	15	156	5	0	176	721
07:45	32	34	32	0	98	20	268	13	0	301	13	37	18	0	68	27	182	7	0	216	683
08:00	26	33	29	0	88	15	288	28	0	331	6	41	20	0	67	16	180	8	0	204	690
08:15	26	58	40	2	126	24	276	24	0	324	13	59	16	0	88	34	127	9	0	170	708
Total Volume	116	159	141	2	418	72	1171	85	0	1328	50	167	73	0	290	92	645	29	0	766	2802
% App. Total	27.8	38	33.7	0.5		5.4	88.2	6.4	0		17.2	57.6	25.2	0		12	84.2	3.8	0		
PHF	.906	.685	.881	.250	.829	.750	.864	.759	.000	.892	.694	.708	.913	.000	.824	.676	.886	.806	.000	.887	.972

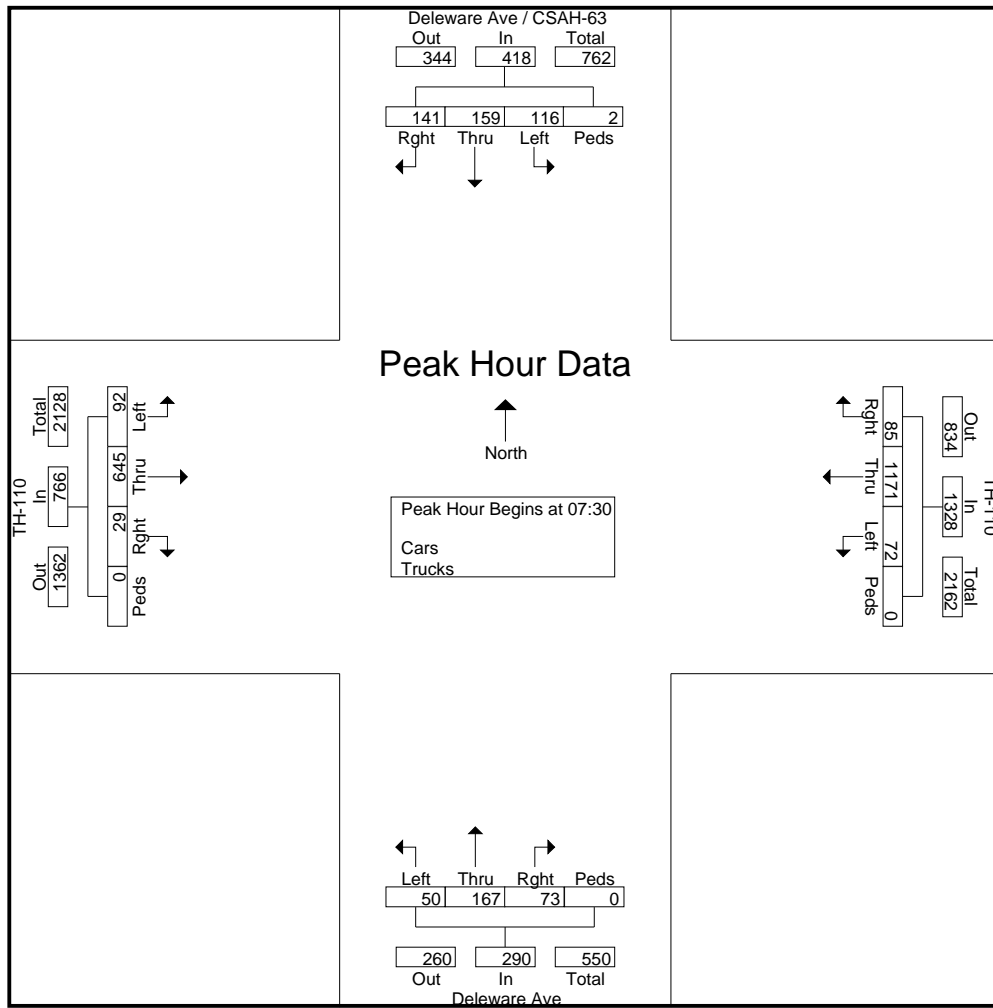

Alliant Engineering

Minneapolis, MN 55415

--TRAFFIC DATA --

TH-110 at Delaware Ave.
 Ref.Pt.: 002.965
 data by Alliant Engineering
 TURN MOVEMENT COUNT

File Name : 416 - TH 110 and Delaware
 Site Code : 416
 Start Date : 4/9/2015
 Page No : 4

Start Time	Deleware Ave / CSAH-63 Southbound					TH-110 Westbound					Deleware Ave Northbound					TH-110 Eastbound					Int. Total
	Left	Thru	Rght	Bikes	App. Total	Left	Thru	Rght	Bikes	App. Total	Left	Thru	Rght	Bikes	App. Total	Left	Thru	Rght	Bikes	App. Total	
Peak Hour Analysis From 12:00 to 18:00 - Peak 1 of 1																					
Peak Hour for Entire Intersection Begins at 16:15																					
16:15	20	18	24	0	62	21	322	23	0	366	8	15	18	0	41	15	424	18	0	457	926
16:30	17	22	24	0	63	40	326	29	0	395	4	12	16	0	32	37	381	22	0	440	930
16:45	25	30	27	0	82	31	327	21	0	379	7	25	22	0	54	37	473	14	0	524	1039
17:00	15	27	17	0	59	32	321	21	0	374	9	27	19	0	55	33	445	21	0	499	987
Total Volume	77	97	92	0	266	124	1296	94	0	1514	28	79	75	0	182	122	1723	75	0	1920	3882
% App. Total	28.9	36.5	34.6	0		8.2	85.6	6.2	0		15.4	43.4	41.2	0		6.4	89.7	3.9	0		
PHF	.770	.808	.852	.000	.811	.775	.991	.810	.000	.958	.778	.731	.852	.000	.827	.824	.911	.852	.000	.916	.934

