

MN Dept of Transportation

TRAFFIC DATA COLLECTION - Metro

TH-97 at N Shore Trl / Keswick Ave
 Ref.Pt.: 006.938
 video RE
 TURN MOVEMENT COUNT

File Name : TH-97 at N Shore Trl Keswick Ave 2015
 Site Code :
 Start Date : 4/14/2015
 Page No : 1

Groups Printed- Cars +

Start Time	North Shore Trail Southbound				TH-97 Westbound				Keswick Ave Northbound				TH-97 Eastbound				Int. Total
	Left	Thru	Right	Peds	Left	Thru	Right	Peds	Left	Thru	Right	Peds	Left	Thru	Right	Peds	
06:00	4	0	12	0	0	85	0	0	1	0	0	0	1	13	0	0	116
06:15	8	0	13	0	0	93	2	0	0	0	0	0	1	19	0	0	136
06:30	4	0	14	0	0	82	0	0	0	0	1	0	1	33	1	0	136
06:45	7	0	10	0	0	110	4	0	2	0	0	0	1	30	0	0	164
Total	23	0	49	0	0	370	6	0	3	0	1	0	4	95	1	0	552
07:00	7	0	21	0	0	106	1	0	0	1	0	0	1	35	0	0	172
07:15	6	0	36	0	0	126	1	0	1	0	0	0	1	55	0	0	226
07:30	7	0	15	0	0	119	4	0	2	0	0	0	6	64	0	0	217
07:45	4	0	8	0	0	81	0	0	0	0	0	0	4	54	0	0	151
Total	24	0	80	0	0	432	6	0	3	1	0	0	12	208	0	0	766
08:00	8	0	10	0	0	82	2	0	0	0	0	0	4	50	1	0	157
08:15	7	0	10	0	0	85	2	0	2	0	0	0	2	41	0	0	149
08:30	5	0	8	0	1	79	4	0	1	0	2	0	6	45	0	0	151
08:45	8	0	14	0	0	61	2	0	0	0	0	0	4	32	1	0	122
Total	28	0	42	0	1	307	10	0	3	0	2	0	16	168	2	0	579
***** BREAK *****																	
15:00	7	0	11	0	0	61	6	0	0	0	0	0	13	89	0	0	187
15:15	5	1	7	0	0	53	3	0	0	0	0	0	16	97	1	0	183
15:30	6	0	11	0	0	76	8	0	0	0	0	0	10	102	0	0	213
15:45	4	0	2	0	2	83	8	0	1	0	0	0	10	116	1	0	227
Total	22	1	31	0	2	273	25	0	1	0	0	0	49	404	2	0	810
16:00	4	0	9	0	1	63	6	0	0	0	0	0	10	138	0	0	231
16:15	4	0	11	0	1	83	7	0	0	0	0	0	18	108	0	0	232
16:30	4	0	8	0	0	78	9	0	0	0	0	0	15	98	0	0	212
16:45	4	0	11	0	0	65	7	0	0	0	0	0	25	115	3	0	230
Total	16	0	39	0	2	289	29	0	0	0	0	0	68	459	3	0	905
17:00	8	0	9	0	1	78	10	0	1	0	0	0	13	141	0	0	261
17:15	5	0	8	0	0	70	14	0	0	0	0	0	15	106	1	0	219
17:30	7	0	20	0	0	68	13	0	1	0	1	0	16	121	1	0	248
17:45	7	0	11	0	0	63	9	0	0	0	0	0	14	105	0	0	209
Total	27	0	48	0	1	279	46	0	2	0	1	0	58	473	2	0	937
Grand Total	140	1	289	0	6	1950	122	0	12	1	4	0	207	1807	10	0	4549
Apprch %	32.6	0.2	67.2	0	0.3	93.8	5.9	0	70.6	5.9	23.5	0	10.2	89.3	0.5	0	
Total %	3.1	0	6.4	0	0.1	42.9	2.7	0	0.3	0	0.1	0	4.6	39.7	0.2	0	

MN Dept of Transportation

TRAFFIC DATA COLLECTION - Metro

TH-97 at N Shore Trl / Keswick Ave
 Ref.Pt.: 006.938
 video RE
 TURN MOVEMENT COUNT

File Name : TH-97 at N Shore Trl Keswick Ave 2015
 Site Code :
 Start Date : 4/14/2015
 Page No : 2

Start Time	North Shore Trail Southbound					TH-97 Westbound					Keswick Ave Northbound					TH-97 Eastbound					Int. Total
	Left	Thru	Right	Peds	App. Total	Left	Thru	Right	Peds	App. Total	Left	Thru	Right	Peds	App. Total	Left	Thru	Right	Peds	App. Total	
Peak Hour Analysis From 06:00 to 08:45 - Peak 1 of 1																					
Peak Hour for Entire Intersection Begins at 06:45																					
06:45	7	0	10	0	17	0	110	4	0	114	2	0	0	0	2	1	30	0	0	31	164
07:00	7	0	21	0	28	0	106	1	0	107	0	1	0	0	1	1	35	0	0	36	172
07:15	6	0	36	0	42	0	126	1	0	127	1	0	0	0	1	1	55	0	0	56	226
07:30	7	0	15	0	22	0	119	4	0	123	2	0	0	0	2	6	64	0	0	70	217
Total Volume	27	0	82	0	109	0	461	10	0	471	5	1	0	0	6	9	184	0	0	193	779
% App. Total	24.8	0	75.2	0		0	97.9	2.1	0		83.3	16.7	0	0		4.7	95.3	0	0		
PHF	.964	.000	.569	.000	.649	.000	.915	.625	.000	.927	.625	.250	.000	.000	.750	.375	.719	.000	.000	.689	.862

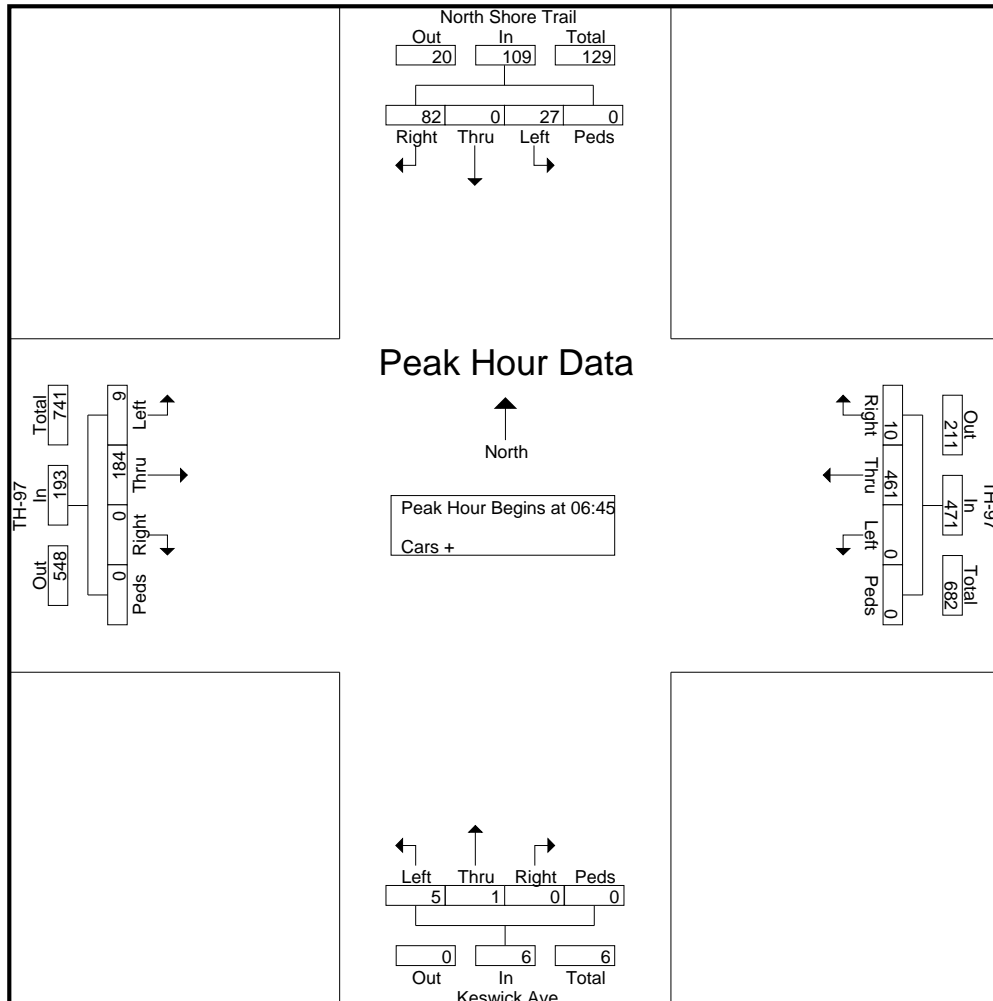

MN Dept of Transportation

TRAFFIC DATA COLLECTION - Metro

TH-97 at N Shore Trl / Keswick Ave
 Ref.Pt.: 006.938
 video RE
 TURN MOVEMENT COUNT

File Name : TH-97 at N Shore Trl Keswick Ave 2015
 Site Code :
 Start Date : 4/14/2015
 Page No : 3

Start Time	North Shore Trail Southbound					TH-97 Westbound					Keswick Ave Northbound					TH-97 Eastbound					Int. Total
	Left	Thru	Right	Peds	App. Total	Left	Thru	Right	Peds	App. Total	Left	Thru	Right	Peds	App. Total	Left	Thru	Right	Peds	App. Total	
Peak Hour Analysis From 15:00 to 17:45 - Peak 1 of 1																					
Peak Hour for Entire Intersection Begins at 16:45																					
16:45	4	0	11	0	15	0	65	7	0	72	0	0	0	0	0	25	115	3	0	143	230
17:00	8	0	9	0	17	1	78	10	0	89	1	0	0	0	1	13	141	0	0	154	261
17:15	5	0	8	0	13	0	70	14	0	84	0	0	0	0	0	15	106	1	0	122	219
17:30	7	0	20	0	27	0	68	13	0	81	1	0	1	0	2	16	121	1	0	138	248
Total Volume	24	0	48	0	72	1	281	44	0	326	2	0	1	0	3	69	483	5	0	557	958
% App. Total	33.3	0	66.7	0		0.3	86.2	13.5	0		66.7	0	33.3	0		12.4	86.7	0.9	0		
PHF	.750	.000	.600	.000	.667	.250	.901	.786	.000	.916	.500	.000	.250	.000	.375	.690	.856	.417	.000	.904	.918

