



MINNESOTA DEPT OF TRANSPORTATION

TRAFFIC DATA COLLECTION - METRO

TH-212 at TH-284 / CSAH-53

Ref.Pt.: 138.622

Video JI

TURN MOVEMENT COUNT

File Name : th-212 at th-284 2013revised

Site Code :

Start Date : 10/2/2013

Page No : 1

Groups Printed- Cars +

Start Time	TH-284 Southbound				TH-212 Westbound				CSAH-53 Northbound				TH-212 Eastbound				Int. Total
	Right	Thru	Left	Peds	Right	Thru	Left	Peds	Right	Thru	Left	Peds	Right	Thru	Left	Peds	
06:00	7	3	5	0	1	27	2	0	11	5	1	0	1	153	5	0	221
06:15	0	10	12	0	8	53	2	0	23	9	1	0	1	180	2	0	301
06:30	9	6	10	0	10	61	1	0	20	11	3	0	5	223	6	0	365
06:45	9	10	12	0	8	89	2	0	11	13	2	0	6	178	4	0	344
Total	25	29	39	0	27	230	7	0	65	38	7	0	13	734	17	0	1231
07:00	2	10	9	0	4	59	6	0	23	9	0	0	1	218	5	0	346
07:15	6	6	19	0	8	67	14	0	16	15	0	0	10	173	9	0	343
07:30	6	10	13	0	6	69	9	0	20	13	5	0	4	178	4	0	337
07:45	6	5	12	0	7	62	8	0	12	19	1	0	12	176	7	0	327
Total	20	31	53	0	25	257	37	0	71	56	6	0	27	745	25	0	1353
08:00	12	6	16	0	8	37	10	0	18	16	1	0	20	121	3	0	268
08:15	5	4	13	0	3	51	14	0	25	19	1	0	14	91	2	0	242
08:30	2	5	11	0	3	60	3	0	23	11	0	0	4	114	3	0	239
08:45	2	6	11	0	6	60	2	0	12	12	3	0	6	71	3	0	194
Total	21	21	51	0	20	208	29	0	78	58	5	0	44	397	11	0	943
***** BREAK *****																	
15:00	4	25	4	0	13	100	14	0	0	11	1	0	2	75	4	0	253
15:15	12	11	4	0	11	132	11	0	1	12	1	0	4	90	2	0	291
15:30	9	12	8	0	10	156	16	0	3	12	1	0	11	92	5	0	335
15:45	2	11	4	0	18	170	10	0	12	21	4	0	2	74	3	0	331
Total	27	59	20	0	52	558	51	0	16	56	7	0	19	331	14	0	1210
16:00	7	10	5	0	13	148	12	0	0	12	2	0	5	75	2	0	291
16:15	1	13	3	0	13	190	9	0	1	9	0	0	5	113	3	0	360
16:30	16	20	4	0	17	156	14	0	11	14	1	0	4	66	2	0	325
16:45	15	23	4	0	22	203	7	0	7	18	4	0	3	72	2	0	380
Total	39	66	16	0	65	697	42	0	19	53	7	0	17	326	9	0	1356
17:00	13	16	5	0	16	151	18	0	5	18	1	0	3	89	4	0	339
17:15	8	15	6	0	13	210	19	0	7	4	2	0	3	70	4	0	361
17:30	15	14	4	0	10	131	14	0	5	8	2	0	4	45	2	0	254
17:45	10	7	4	0	9	138	17	0	2	14	2	0	11	66	5	0	285
Total	46	52	19	0	48	630	68	0	19	44	7	0	21	270	15	0	1239
Grand Total	178	258	198	0	237	2580	234	0	268	305	39	0	141	2803	91	0	7332
Apprch %	28.1	40.7	31.2	0	7.8	84.6	7.7	0	43.8	49.8	6.4	0	4.6	92.4	3	0	
Total %	2.4	3.5	2.7	0	3.2	35.2	3.2	0	3.7	4.2	0.5	0	1.9	38.2	1.2	0	



MINNESOTA DEPT OF TRANSPORTATION

TRAFFIC DATA COLLECTION - METRO

TH-212 at TH-284 / CSAH-53
 Ref.Pt.: 138.622
 Video JI
 TURN MOVEMENT COUNT

File Name : th-212 at th-284 2013revised
 Site Code :
 Start Date : 10/2/2013
 Page No : 2

Start Time	TH-284 Southbound					TH-212 Westbound					CSAH-53 Northbound					TH-212 Eastbound					Int. Total
	Right	Thru	Left	Peds	App. Total	Right	Thru	Left	Peds	App. Total	Right	Thru	Left	Peds	App. Total	Right	Thru	Left	Peds	App. Total	
Peak Hour Analysis From 06:00 to 08:45 - Peak 1 of 1																					
Peak Hour for Entire Intersection Begins at 06:30																					
06:30	9	6	10	0	25	10	61	1	0	72	20	11	3	0	34	5	223	6	0	234	365
06:45	9	10	12	0	31	8	89	2	0	99	11	13	2	0	26	6	178	4	0	188	344
07:00	2	10	9	0	21	4	59	6	0	69	23	9	0	0	32	1	218	5	0	224	346
07:15	6	6	19	0	31	8	67	14	0	89	16	15	0	0	31	10	173	9	0	192	343
Total Volume	26	32	50	0	108	30	276	23	0	329	70	48	5	0	123	22	792	24	0	838	1398
% App. Total	24.1	29.6	46.3	0		9.1	83.9	7	0		56.9	39	4.1	0		2.6	94.5	2.9	0		
PHF	.722	.800	.658	.000	.871	.750	.775	.411	.000	.831	.761	.800	.417	.000	.904	.550	.888	.667	.000	.895	.958

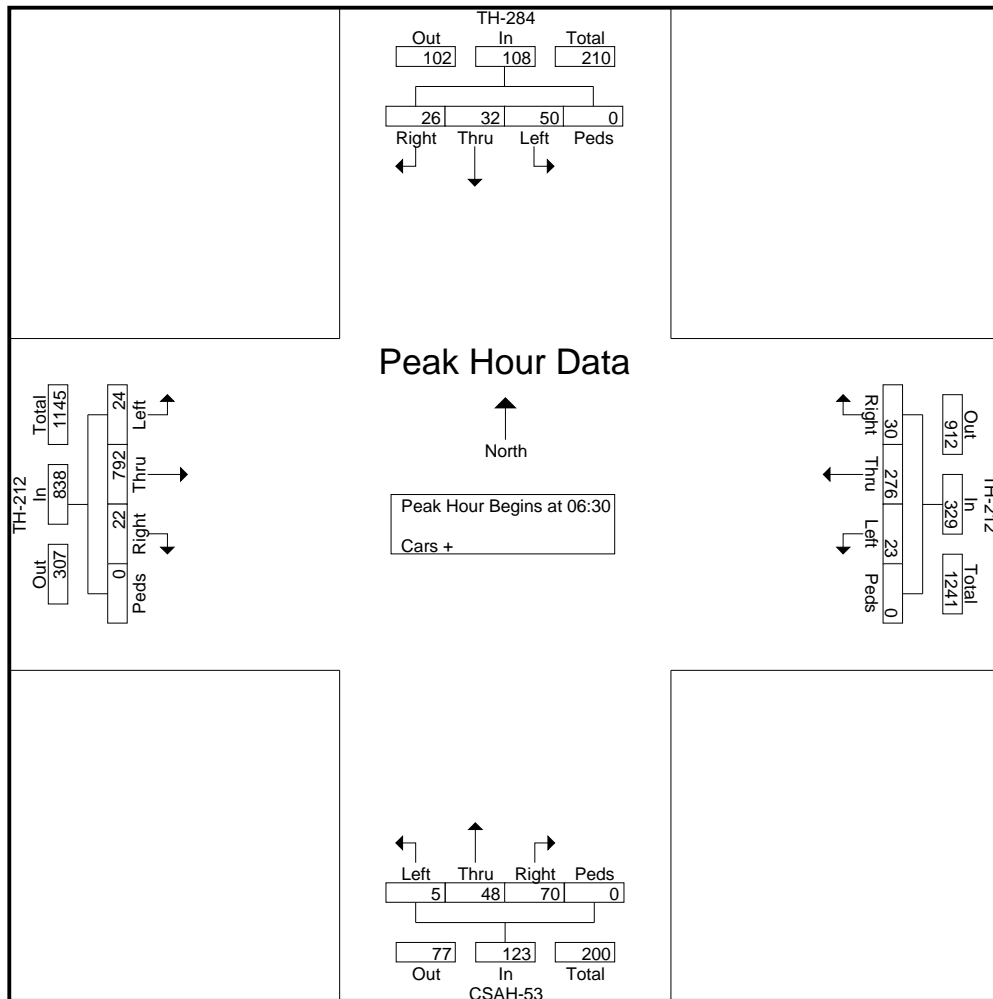



MINNESOTA DEPT OF TRANSPORTATION

TRAFFIC DATA COLLECTION - METRO

TH-212 at TH-284 / CSAH-53
 Ref.Pt.: 138.622
 Video JI
 TURN MOVEMENT COUNT

File Name : th-212 at th-284 2013revised
 Site Code :
 Start Date : 10/2/2013
 Page No : 3

Start Time	TH-284 Southbound					TH-212 Westbound					CSAH-53 Northbound					TH-212 Eastbound					Int. Total
	Rig ht	Thr u	Left	Ped s	App. Total	Rig ht	Thr u	Left	Ped s	App. Total	Right	Thr u	Left	Peds	App. Total	Right	Thr u	Left	Peds	App. Total	
16:30	16	20	4	0	40	17	156	14	0	187	11	14	1	0	26	4	66	2	0	72	325
16:45	15	23	4	0	42	22	203	7	0	232	7	18	4	0	29	3	72	2	0	77	380
17:00	13	16	5	0	34	16	151	18	0	185	5	18	1	0	24	3	89	4	0	96	339
17:15	8	15	6	0	29	13	210	19	0	242	7	4	2	0	13	3	70	4	0	77	361
Total Volume	52	74	19	0	145	68	720	58	0	846	30	54	8	0	92	13	297	12	0	322	1405
% App. Total	35.9	51	13.1	0		8	85.1	6.9	0		32.6	58.7	8.7	0		4	92.2	3.7	0		
PHF	.813	.804	.792	.000	.863	.773	.857	.763	.000	.874	.682	.750	.500	.000	.793	.813	.834	.750	.000	.839	.924

Peak Hour Analysis From 15:00 to 17:45 - Peak 1 of 1
 Peak Hour for Entire Intersection Begins at 16:30

