

Short Elliott Hendrickson Inc.

3535 Vadnais Center Drive
St. Paul, MN 55110

"Building a Better World for All of Us"



TRAFFIC DATA

CSAH 56 (Concord Blvd) & Cahill Ave
Ref.Pt.: 120.730
Data By: Short Elliott Hendrickson, Inc.
TURN MOVEMENT COUNT

File Name : CSAH 56 (Concord Blvd) & Cahill Ave 2019
Site Code : 1b
Start Date : 5/2/2019
Page No : 1

Groups Printed- Vehicles - Trucks

Start Time	Southbound					Westbound					Northbound					Eastbound					Int. Total
	Left	Thru	Right	Peds	App. Total	Left	Thru	Right	Peds	App. Total	Left	Thru	Right	Peds	App. Total	Left	Thru	Right	Peds	App. Total	
06:00	1	1	6	0	8	4	62	3	0	69	8	1	1	0	10	4	20	7	0	31	118
06:15	1	3	11	0	15	8	57	0	0	65	26	3	3	0	32	10	28	11	0	49	161
06:30	0	8	22	0	30	7	81	1	2	91	24	3	2	0	29	8	34	15	0	57	207
06:45	3	7	17	0	27	11	66	4	0	81	25	5	5	0	35	11	36	9	0	56	199
Total	5	19	56	0	80	30	266	8	2	306	83	12	11	0	106	33	118	42	0	193	685
07:00	1	7	14	0	22	7	74	5	0	86	21	5	2	0	28	19	35	15	0	69	205
07:15	12	20	40	0	72	12	79	13	0	104	12	12	1	0	25	18	37	18	0	73	274
07:30	12	8	45	0	65	9	72	7	0	88	37	17	6	1	61	16	39	23	0	78	292
07:45	3	9	17	0	29	13	67	5	0	85	22	10	7	0	39	14	51	19	0	84	237
Total	28	44	116	0	188	41	292	30	0	363	92	44	16	1	153	67	162	75	0	304	1008
08:00	4	22	13	0	39	22	67	1	0	90	42	6	13	0	61	12	42	29	0	83	273
08:15	3	13	12	0	28	15	58	4	0	77	42	33	10	0	85	12	32	20	0	64	254
08:30	3	5	15	0	23	16	46	1	0	63	28	8	2	0	38	13	31	18	0	62	186
08:45	3	6	10	0	19	7	40	4	0	51	28	3	2	0	33	10	33	22	0	65	168
Total	13	46	50	0	109	60	211	10	0	281	140	50	27	0	217	47	138	89	0	274	881
09:00	1	8	9	1	19	13	50	6	0	69	24	10	5	0	39	15	28	11	1	55	182
09:15	1	9	14	0	24	7	55	5	0	67	21	9	6	0	36	21	34	23	0	78	205
09:30	5	15	15	1	36	6	44	2	0	52	14	12	8	0	34	12	26	17	1	56	178
09:45	4	16	7	1	28	8	42	4	0	54	23	9	3	0	35	21	34	11	0	66	183
Total	11	48	45	3	107	34	191	17	0	242	82	40	22	0	144	69	122	62	2	255	748
10:00	3	14	12	0	29	6	42	2	0	50	11	12	3	0	26	16	32	16	1	65	170
10:15	3	21	7	0	31	13	26	3	0	42	8	8	5	0	21	16	22	14	0	52	146
10:30	3	13	17	1	34	18	31	5	0	54	20	5	4	0	29	24	36	14	0	74	191
10:45	5	13	14	0	32	3	44	4	0	51	30	8	6	0	44	18	35	20	1	74	201
Total	14	61	50	1	126	40	143	14	0	197	69	33	18	0	120	74	125	64	2	265	708
11:00	4	20	15	0	39	14	41	3	1	59	25	14	6	0	45	18	40	12	0	70	213
11:15	1	17	10	0	28	15	29	1	0	45	26	10	9	0	45	19	26	20	0	65	183
11:30	3	13	16	0	32	8	31	3	0	42	25	12	7	0	44	21	37	17	1	76	194
11:45	7	17	17	0	41	14	29	4	0	47	30	9	6	0	45	22	42	17	0	81	214
Total	15	67	58	0	140	51	130	11	1	193	106	45	28	0	179	80	145	66	1	292	804
12:00	3	14	17	2	36	11	41	5	0	57	30	9	9	2	50	26	38	15	0	79	222
12:15	5	21	16	0	42	15	40	3	0	58	31	11	5	0	47	26	37	17	0	80	227
12:30	4	15	16	0	35	17	41	6	0	64	21	8	11	0	40	23	46	16	0	85	224
12:45	3	20	26	0	49	12	36	4	0	52	28	10	8	0	46	33	46	23	0	102	249
Total	15	70	75	2	162	55	158	18	0	231	110	38	33	2	183	108	167	71	0	346	922
13:00	1	8	19	0	28	7	39	2	0	48	26	13	6	0	45	12	46	17	0	75	196
13:15	4	17	18	0	39	11	38	2	0	51	31	10	7	0	48	23	46	18	1	88	226
13:30	5	14	16	1	36	7	49	4	1	61	25	12	9	0	46	32	46	14	0	92	235
13:45	6	14	16	0	36	11	40	9	0	60	23	5	9	0	37	30	53	17	0	100	233
Total	16	53	69	1	139	36	166	17	1	220	105	40	31	0	176	97	191	66	1	355	890

Short Elliott Hendrickson Inc.

3535 Vadnais Center Drive
St. Paul, MN 55110

"Building a Better World for All of Us"



TRAFFIC DATA

CSAH 56 (Concord Blvd) & Cahill Ave
Ref.Pt.: 120.730
Data By: Short Elliott Hendrickson, Inc.
TURN MOVEMENT COUNT

File Name : CSAH 56 (Concord Blvd) & Cahill Ave 2019
Site Code : 1b
Start Date : 5/2/2019
Page No : 2

Groups Printed- Vehicles - Trucks

Start Time	Southbound					Westbound					Northbound					Eastbound					Int. Total
	Left	Thru	Right	Peds	App. Total	Left	Thru	Right	Peds	App. Total	Left	Thru	Right	Peds	App. Total	Left	Thru	Right	Peds	App. Total	
14:00	6	24	20	1	51	11	40	3	0	54	27	9	8	0	44	28	45	8	0	81	230
14:15	2	18	13	0	33	6	52	10	0	68	30	15	1	0	46	16	54	19	1	90	237
14:30	8	39	19	0	66	11	52	3	0	66	25	15	6	0	46	28	75	26	0	129	307
14:45	6	25	19	0	50	11	43	7	0	61	21	10	18	2	51	40	72	37	2	151	313
Total	22	106	71	1	200	39	187	23	0	249	103	49	33	2	187	112	246	90	3	451	1087
15:00	9	14	20	1	44	14	48	4	0	66	51	20	15	0	86	25	59	28	0	112	308
15:15	8	21	27	0	56	17	59	5	2	83	33	16	13	0	62	40	66	21	0	127	328
15:30	4	23	11	1	39	13	47	7	0	67	26	22	9	0	57	31	98	27	0	156	319
15:45	5	19	20	2	46	14	55	6	1	76	41	18	15	0	74	37	97	26	2	162	358
Total	26	77	78	4	185	58	209	22	3	292	151	76	52	0	279	133	320	102	2	557	1313
16:00	9	29	18	0	56	7	54	8	2	71	38	16	20	0	74	49	101	26	0	176	377
16:15	6	21	12	1	40	10	81	9	1	101	34	14	11	0	59	30	89	28	0	147	347
16:30	8	12	9	1	30	15	58	4	0	77	38	15	13	0	66	44	100	18	2	164	337
16:45	5	15	16	1	37	22	62	11	0	95	21	19	15	0	55	37	120	26	1	184	371
Total	28	77	55	3	163	54	255	32	3	344	131	64	59	0	254	160	410	98	3	671	1432
17:00	9	12	25	0	46	16	79	7	0	102	38	16	10	0	64	36	102	24	0	162	374
17:15	5	18	23	0	46	17	65	5	0	87	37	18	13	0	68	52	129	29	0	210	411
17:30	3	17	15	1	36	16	70	8	0	94	29	22	12	1	64	28	114	34	0	176	370
17:45	6	20	13	1	40	8	51	2	2	63	29	13	11	0	53	39	67	23	0	129	285
Total	23	67	76	2	168	57	265	22	2	346	133	69	46	1	249	155	412	110	0	677	1440
18:00	5	19	19	1	44	14	63	6	2	85	29	14	6	0	49	33	78	14	0	125	303
18:15	11	26	14	2	53	18	51	5	0	74	17	17	13	0	47	25	74	27	0	126	300
18:30	7	14	16	0	37	11	36	4	2	53	31	13	8	0	52	21	59	18	0	98	240
18:45	2	14	7	1	24	14	30	3	0	47	27	8	11	0	46	29	55	13	0	97	214
Total	25	73	56	4	158	57	180	18	4	259	104	52	38	0	194	108	266	72	0	446	1057
Grand Total	241	808	855	21	1925	612	2653	242	16	3523	1409	612	414	6	2441	1243	2822	1007	14	5086	12975
Apprch %	12.5	42	44.4	1.1		17.4	75.3	6.9	0.5		57.7	25.1	17	0.2		24.4	55.5	19.8	0.3		
Total %	1.9	6.2	6.6	0.2	14.8	4.7	20.4	1.9	0.1	27.2	10.9	4.7	3.2	0	18.8	9.6	21.7	7.8	0.1	39.2	
Vehicles	236	790	837	18	1881	592	2497				1358					1220	2660				12427
% Vehicles	97.9	97.8	97.9	85.7	97.7	96.7	94.1	95.9	100	94.7	96.4	95.8	96.1	83.3	96.1	98.1	94.3	96.4	78.6	95.6	95.8
Trucks	5	18	18	3	44	20	156	10	0	186	51	26	16	1	94	23	162	36	3	224	548
% Trucks	2.1	2.2	2.1	14.3	2.3	3.3	5.9	4.1	0	5.3	3.6	4.2	3.9	16.7	3.9	1.9	5.7	3.6	21.4	4.4	4.2

Short Elliott Hendrickson Inc.

3535 Vadnais Center Drive
St. Paul, MN 55110

"Building a Better World for All of Us"



TRAFFIC DATA

CSAH 56 (Concord Blvd) & Cahill Ave
Ref.Pt.: 120.730
Data By: Short Elliott Hendrickson, Inc.
TURN MOVEMENT COUNT

File Name : CSAH 56 (Concord Blvd) & Cahill Ave 2019
Site Code : 1b
Start Date : 5/2/2019
Page No : 3

Start Time	Southbound					Westbound					Northbound					Eastbound					Int. Total
	Left	Thru	Right	Peds	App. Total	Left	Thru	Right	Peds	App. Total	Left	Thru	Right	Peds	App. Total	Left	Thru	Right	Peds	App. Total	
Peak Hour Analysis From 06:00 to 08:45 - Peak 1 of 1 Peak Hour for Entire Intersection Begins at 07:15																					
07:15	12	20	40	0	72	12	79	13	0	104	12	12	1	0	25	18	37	18	0	73	274
07:30	12	8	45	0	65	9	72	7	0	88	37	17	6	1	61	16	39	23	0	78	292
07:45	3	9	17	0	29	13	67	5	0	85	22	10	7	0	39	14	51	19	0	84	237
08:00	4	22	13	0	39	22	67	1	0	90	42	6	13	0	61	12	42	29	0	83	273
Total Volume	31	59	115	0	205	56	285	26	0	367	113	45	27	1	186	60	169	89	0	318	1076
% App. Total	15.1	28.8	56.1	0		15.3	77.7	7.1	0		60.8	24.2	14.5	0.5		18.9	53.1	28	0		
PHF	.646	.670	.639	.000	.712	.636	.902	.500	.000	.882	.673	.662	.519	.250	.762	.833	.828	.767	.000	.946	.921

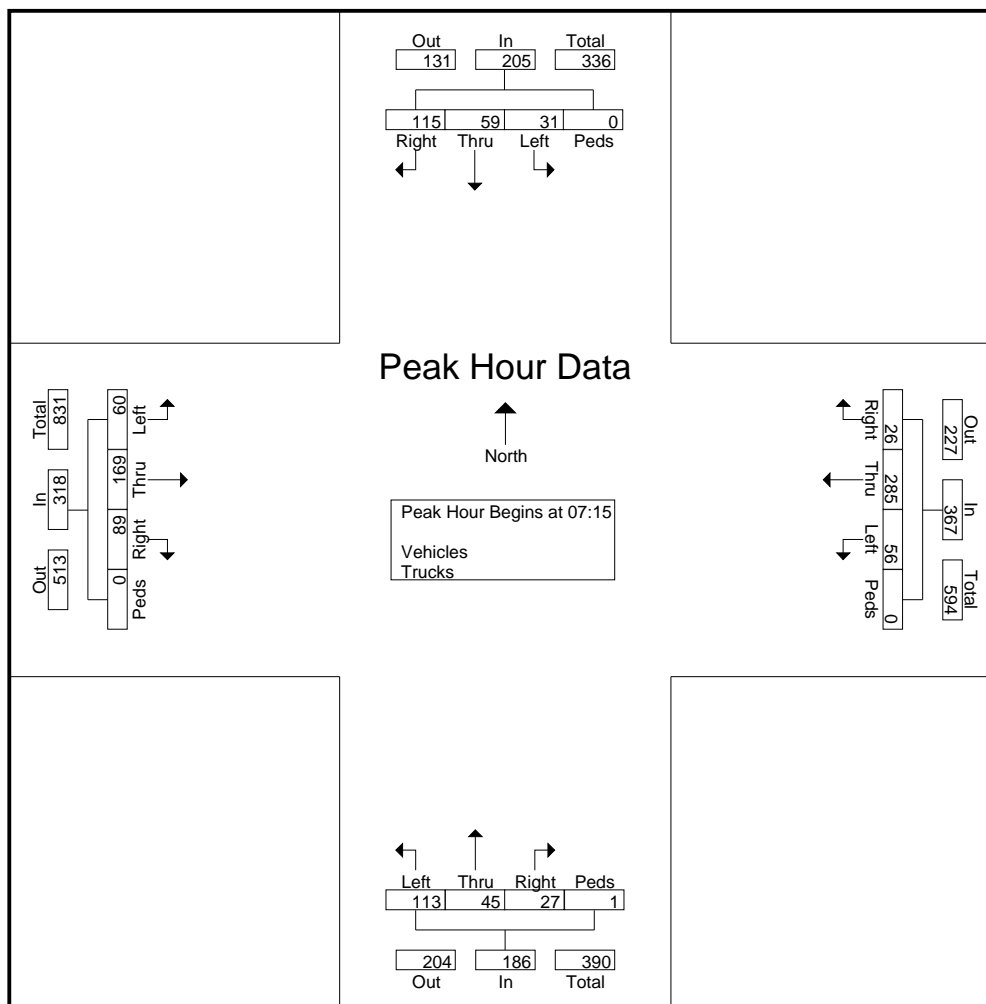

Short Elliott Hendrickson Inc.

3535 Vadnais Center Drive
St. Paul, MN 55110

"Building a Better World for All of Us"



TRAFFIC DATA

CSAH 56 (Concord Blvd) & Cahill Ave
Ref.Pt.: 120.730
Data By: Short Elliott Hendrickson, Inc.
TURN MOVEMENT COUNT

File Name : CSAH 56 (Concord Blvd) & Cahill Ave 2019
Site Code : 1b
Start Date : 5/2/2019
Page No : 4

Start Time	Southbound					Westbound					Northbound					Eastbound					Int. Total
	Left	Thru	Right	Peds	App. Total	Left	Thru	Right	Peds	App. Total	Left	Thru	Right	Peds	App. Total	Left	Thru	Right	Peds	App. Total	
Peak Hour Analysis From 11:00 to 12:45 - Peak 1 of 1 Peak Hour for Entire Intersection Begins at 12:00																					
12:00	3	14	17	2	36	11	41	5	0	57	30	9	9	2	50	26	38	15	0	79	222
12:15	5	21	16	0	42	15	40	3	0	58	31	11	5	0	47	26	37	17	0	80	227
12:30	4	15	16	0	35	17	41	6	0	64	21	8	11	0	40	23	46	16	0	85	224
12:45	3	20	26	0	49	12	36	4	0	52	28	10	8	0	46	33	46	23	0	102	249
Total Volume	15	70	75	2	162	55	158	18	0	231	110	38	33	2	183	108	167	71	0	346	922
% App. Total	9.3	43.2	46.3	1.2		23.8	68.4	7.8	0		60.1	20.8	18	1.1		31.2	48.3	20.5	0		
PHF	.750	.833	.721	.250	.827	.809	.963	.750	.000	.902	.887	.864	.750	.250	.915	.818	.908	.772	.000	.848	.926

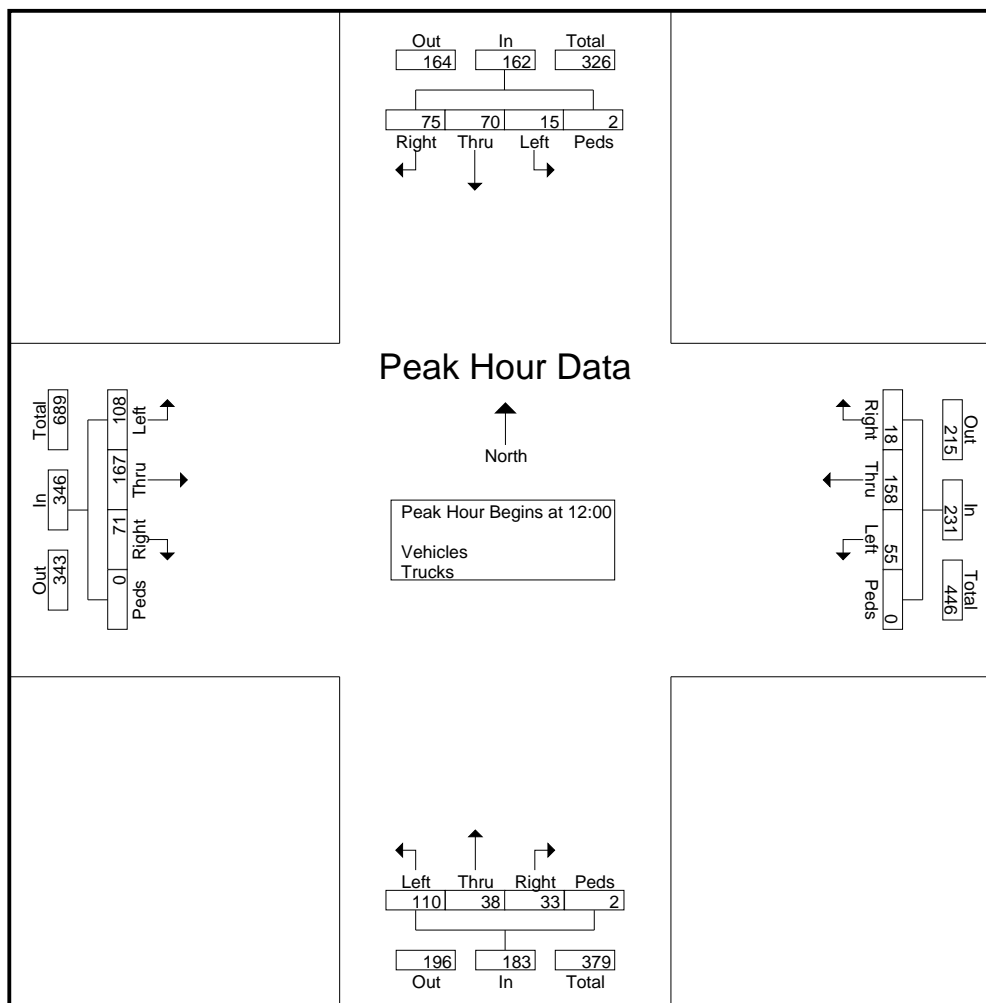

Short Elliott Hendrickson Inc.

3535 Vadnais Center Drive
St. Paul, MN 55110

"Building a Better World for All of Us"



TRAFFIC DATA

CSAH 56 (Concord Blvd) & Cahill Ave
Ref.Pt.: 120.730
Data By: Short Elliott Hendrickson, Inc.
TURN MOVEMENT COUNT

File Name : CSAH 56 (Concord Blvd) & Cahill Ave 2019
Site Code : 1b
Start Date : 5/2/2019
Page No : 5

Start Time	Southbound					Westbound					Northbound					Eastbound					Int. Total
	Left	Thru	Right	Peds	App. Total	Left	Thru	Right	Peds	App. Total	Left	Thru	Right	Peds	App. Total	Left	Thru	Right	Peds	App. Total	
Peak Hour Analysis From 15:00 to 17:45 - Peak 1 of 1 Peak Hour for Entire Intersection Begins at 16:45																					
16:45	5	15	16	1	37	22	62	11	0	95	21	19	15	0	55	37	120	26	1	184	371
17:00	9	12	25	0	46	16	79	7	0	102	38	16	10	0	64	36	102	24	0	162	374
17:15	5	18	23	0	46	17	65	5	0	87	37	18	13	0	68	52	129	29	0	210	411
17:30	3	17	15	1	36	16	70	8	0	94	29	22	12	1	64	28	114	34	0	176	370
Total Volume	22	62	79	2	165	71	276	31	0	378	125	75	50	1	251	153	465	113	1	732	1526
% App. Total	13.3	37.6	47.9	1.2		18.8	73	8.2	0		49.8	29.9	19.9	0.4		20.9	63.5	15.4	0.1		
PHF	.611	.861	.790	.500	.897	.807	.873	.705	.000	.926	.822	.852	.833	.250	.923	.736	.901	.831	.250	.871	.928

