

MN Dept of Transportation

TRAFFIC DATA COLLECTION - Metro

TH-52 NB at 70th St /CSAH-26 (E ramps)

Ref.Pt.: 123.505

video AL

TURN MOVEMENT COUNT

File Name : TH-52 at 70th St EAST Ramps 2015

Site Code :

Start Date : 7/22/2015

Page No : 1

Groups Printed- Cars +

Start Time	ramp to TH-52 NB Southbound				70th St / CSAH-26 Westbound				ramp from TH-52 NB Northbound				70th St / CSAH-26 Eastbound				Int. Total
	Left	Thru	Right	Peds	Left	Thru	Right	Peds	Left	Thru	Right	Peds	Left	Thru	Right	Peds	
06:00	0	0	0	0	0	32	81	0	0	0	1	0	31	13	0	0	158
06:15	0	0	0	0	0	38	89	0	0	0	1	0	43	19	0	0	190
06:30	0	0	0	0	0	48	107	0	4	0	3	0	41	23	0	0	226
06:45	0	0	0	0	0	46	106	0	1	0	6	0	44	33	0	0	236
Total	0	0	0	0	0	164	383	0	5	0	11	0	159	88	0	0	810
07:00	0	0	0	0	0	41	118	0	0	0	5	0	42	26	0	0	232
07:15	0	0	0	0	0	40	111	0	2	0	7	0	70	34	0	0	264
07:30	0	0	0	0	0	61	127	0	0	0	7	2	62	37	0	0	296
07:45	0	0	0	0	0	44	98	0	3	0	15	0	48	54	0	0	262
Total	0	0	0	0	0	186	454	0	5	0	34	2	222	151	0	0	1054
08:00	0	0	0	0	0	42	94	0	2	0	2	0	51	41	0	0	232
08:15	0	0	0	0	0	34	75	0	3	0	6	0	33	48	0	0	199
08:30	0	0	0	0	0	33	75	0	0	0	5	0	38	44	0	0	195
08:45	0	0	0	0	0	40	60	0	1	0	4	0	27	41	0	0	173
Total	0	0	0	0	0	149	304	0	6	0	17	0	149	174	0	0	799
09:00	0	0	0	0	0	31	50	0	3	0	4	0	42	43	0	0	173
09:15	0	0	0	0	0	20	46	0	1	0	2	0	26	46	0	0	141
09:30	0	0	0	0	0	26	59	0	1	0	12	0	19	37	0	0	154
09:45	0	0	0	0	0	41	50	0	1	0	6	0	18	50	0	0	166
Total	0	0	0	0	0	118	205	0	6	0	24	0	105	176	0	0	634
10:00	0	0	0	0	0	35	50	0	3	1	9	0	25	42	0	0	165
10:15	0	0	0	0	0	21	45	0	1	0	4	0	31	43	0	0	145
10:30	0	0	0	0	0	38	39	0	1	0	10	2	16	60	0	0	166
10:45	0	0	0	0	0	24	44	0	2	0	2	0	28	60	0	0	160
Total	0	0	0	0	0	118	178	0	7	1	25	2	100	205	0	0	636
11:00	0	0	0	0	0	36	41	0	2	1	7	1	29	47	0	0	164
11:15	0	0	0	0	0	23	42	0	2	1	7	0	15	70	0	0	160
11:30	0	0	0	0	0	30	57	0	1	0	9	0	22	92	0	0	211
11:45	0	0	0	0	0	30	48	2	2	1	8	0	25	49	0	0	165
Total	0	0	0	0	0	119	188	2	7	3	31	1	91	258	0	0	700
12:00	0	0	0	0	0	29	41	0	0	0	4	0	21	56	0	0	151
12:15	0	0	0	0	0	22	46	0	2	0	3	0	26	61	0	0	160
12:30	0	0	0	0	0	47	45	0	0	0	5	0	32	76	0	0	205
12:45	0	0	0	0	0	40	48	0	3	0	3	0	29	65	0	0	188
Total	0	0	0	0	0	138	180	0	5	0	15	0	108	258	0	0	704
13:00	0	0	0	0	0	37	48	0	2	0	5	0	19	67	0	0	178
13:15	0	0	0	0	0	31	44	0	1	0	6	0	29	82	0	0	193
13:30	0	0	0	0	0	31	45	0	1	0	2	0	16	81	0	0	176
13:45	0	0	0	0	0	31	46	0	0	0	5	0	32	72	0	0	186
Total	0	0	0	0	0	130	183	0	4	0	18	0	96	302	0	0	733
14:00	0	0	0	0	0	34	43	0	1	0	5	0	26	79	0	0	188
14:15	0	0	0	0	0	24	36	0	4	0	6	0	26	67	0	0	163
14:30	0	0	0	0	0	52	49	0	1	3	7	0	30	93	0	0	235
14:45	0	0	0	0	0	37	52	0	1	0	8	0	26	93	0	0	217
Total	0	0	0	0	0	147	180	0	7	3	26	0	108	332	0	0	803
15:00	0	0	0	0	0	31	46	0	1	0	7	0	32	96	0	0	213
15:15	0	0	0	0	0	35	46	0	1	0	6	0	52	114	0	0	254
15:30	0	0	0	0	0	33	52	0	3	0	13	0	33	116	0	0	250
15:45	0	0	0	0	0	47	55	0	3	2	21	0	41	134	0	0	303
Total	0	0	0	0	0	146	199	0	8	2	47	0	158	460	0	0	1020

MN Dept of Transportation

TRAFFIC DATA COLLECTION - Metro

TH-52 NB at 70th St /CSAH-26 (E ramps)

Ref.Pt.: 123.505

video AL

TURN MOVEMENT COUNT

File Name : TH-52 at 70th St EAST Ramps 2015

Site Code :

Start Date : 7/22/2015

Page No : 2

Groups Printed- Cars +

Start Time	ramp to TH-52 NB Southbound				70th St / CSAH-26 Westbound				ramp from TH-52 NB Northbound				70th St / CSAH-26 Eastbound				Int. Total
	Left	Thru	Right	Peds	Left	Thru	Right	Peds	Left	Thru	Right	Peds	Left	Thru	Right	Peds	
16:00	0	0	0	0	0	48	46	0	0	0	7	1	46	239	0	0	387
16:15	0	0	0	0	0	28	43	0	2	0	7	0	53	151	0	0	284
16:30	0	0	0	0	0	62	41	0	3	0	9	0	58	147	0	0	320
16:45	0	0	0	0	0	46	48	1	3	0	12	0	47	173	0	0	330
Total	0	0	0	0	0	184	178	1	8	0	35	1	204	710	0	0	1321
17:00	0	0	0	0	0	54	60	0	4	0	12	0	66	141	0	0	337
17:15	0	0	0	0	0	54	46	0	7	0	9	0	55	169	0	0	340
17:30	0	0	0	0	0	49	36	0	3	0	16	3	63	168	0	0	338
17:45	0	0	0	0	0	39	48	0	1	0	10	0	40	153	0	0	291
Total	0	0	0	0	0	196	190	0	15	0	47	3	224	631	0	0	1306
Grand Total	0	0	0	0	0	1795	2822	3	83	9	330	9	1724	3745	0	0	10520
Apprch %	0	0	0	0	0	38.9	61.1	0.1	19.3	2.1	76.6	2.1	31.5	68.5	0	0	
Total %	0	0	0	0	0	17.1	26.8	0	0.8	0.1	3.1	0.1	16.4	35.6	0	0	

MN Dept of Transportation

TRAFFIC DATA COLLECTION - Metro

TH-52 NB at 70th St /CSAH-26 (E ramps)
 Ref.Pt.: 123.505
 video AL
 TURN MOVEMENT COUNT

File Name : TH-52 at 70th St EAST Ramps 2015
 Site Code :
 Start Date : 7/22/2015
 Page No : 3

Start Time	ramp to TH-52 NB Southbound					70th St / CSAH-26 Westbound					ramp from TH-52 NB Northbound					70th St / CSAH-26 Eastbound					Int. Total
	Left	Thru	Right	Peds	App. Total	Left	Thru	Right	Peds	App. Total	Left	Thru	Right	Peds	App. Total	Left	Thru	Right	Peds	App. Total	
Peak Hour Analysis From 06:00 to 11:45 - Peak 1 of 1																					
Peak Hour for Entire Intersection Begins at 07:00																					
07:00	0	0	0	0	0	0	41	118	0	159	0	0	5	0	5	42	26	0	0	68	232
07:15	0	0	0	0	0	0	40	111	0	151	2	0	7	0	9	70	34	0	0	104	264
07:30	0	0	0	0	0	0	61	127	0	188	0	0	7	2	9	62	37	0	0	99	296
07:45	0	0	0	0	0	0	44	98	0	142	3	0	15	0	18	48	54	0	0	102	262
Total Volume	0	0	0	0	0	0	186	454	0	640	5	0	34	2	41	222	151	0	0	373	1054
% App. Total	0	0	0	0	0	0	29.1	70.9	0		12.2	0	82.9	4.9		59.5	40.5	0	0		
PHF	.000	.000	.000	.000	.000	.000	.762	.894	.000	.851	.417	.000	.567	.250	.569	.793	.699	.000	.000	.897	.890

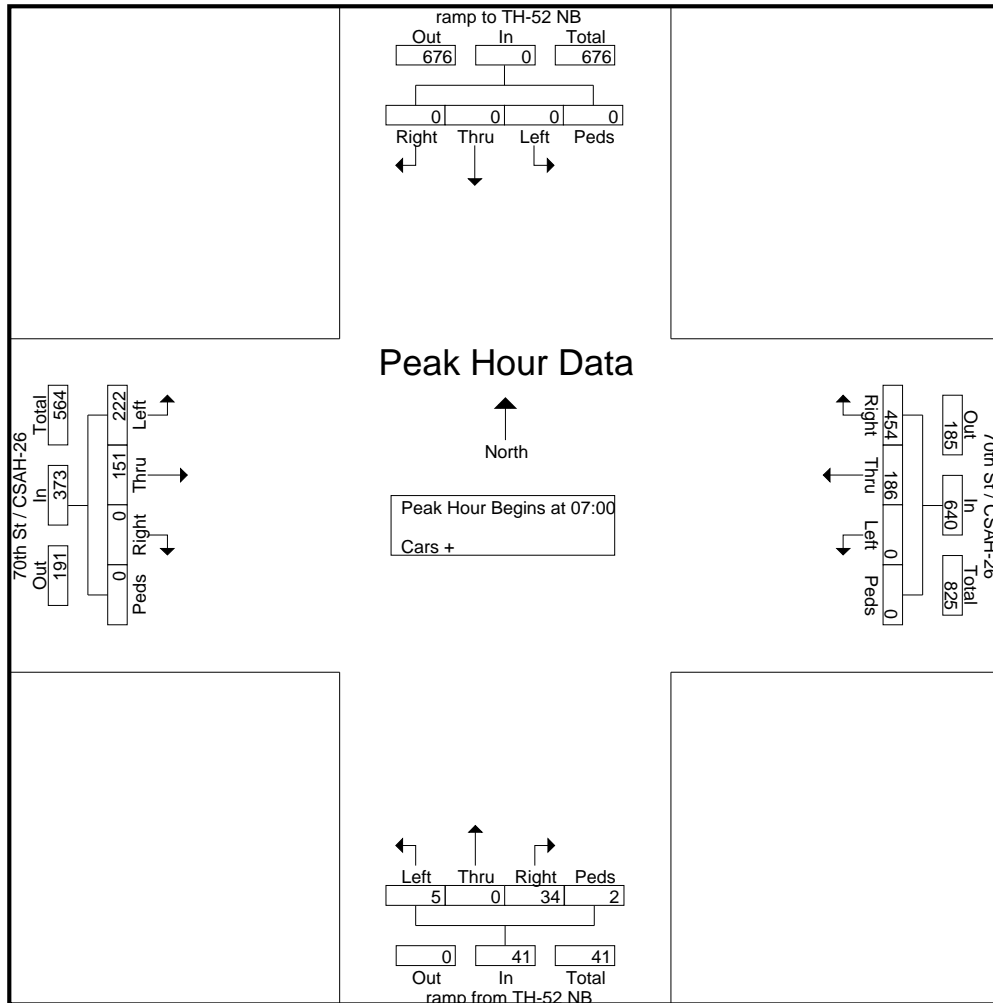

MN Dept of Transportation

TRAFFIC DATA COLLECTION - Metro

TH-52 NB at 70th St /CSAH-26 (E ramps)
 Ref.Pt.: 123.505
 video AL
 TURN MOVEMENT COUNT

File Name : TH-52 at 70th St EAST Ramps 2015
 Site Code :
 Start Date : 7/22/2015
 Page No : 4

Start Time	ramp to TH-52 NB Southbound					70th St / CSAH-26 Westbound					ramp from TH-52 NB Northbound					70th St / CSAH-26 Eastbound					Int. Total
	Left	Thru	Right	Peds	App. Total	Left	Thru	Right	Peds	App. Total	Left	Thru	Right	Peds	App. Total	Left	Thru	Right	Peds	App. Total	
Peak Hour Analysis From 12:00 to 17:45 - Peak 1 of 1																					
Peak Hour for Entire Intersection Begins at 16:45																					
16:45	0	0	0	0	0	0	46	48	1	95	3	0	12	0	15	47	173	0	0	220	330
17:00	0	0	0	0	0	0	54	60	0	114	4	0	12	0	16	66	141	0	0	207	337
17:15	0	0	0	0	0	0	54	46	0	100	7	0	9	0	16	55	169	0	0	224	340
17:30	0	0	0	0	0	0	49	36	0	85	3	0	16	3	22	63	168	0	0	231	338
Total Volume	0	0	0	0	0	0	203	190	1	394	17	0	49	3	69	231	651	0	0	882	1345
% App. Total	0	0	0	0	0	0	51.5	48.2	0.3		24.6	0	71	4.3		26.2	73.8	0	0		
PHF	.000	.000	.000	.000	.000	.000	.940	.792	.250	.864	.607	.000	.766	.250	.784	.875	.941	.000	.000	.955	.989

