



# MINNESOTA DEPT OF TRANSPORTATION

## TRAFFIC DATA COLLECTION - METRO

TH-52 at 70th St. E/CSAH-26, W Ramps  
 Ref.Pt.: 123.505  
 JAMAR #D4-3365  
 TURN MOVEMENT COUNT

File Name : th-52 at 70th ave e csah-26 w ramp 2009  
 Site Code : 00000000  
 Start Date : 6/24/2009  
 Page No : 1

WB 70th St E "right turn" = U Turn  
 EB 70th St E "left turn" = U Turn

### Groups Printed- Cars & Trucks

Start Time	ramp from SB TH-52 Southbound				70th St E / CSAH-26 Westbound				ramp to SB TH-52 Northbound				70th St E / CSAH-26 Eastbound				Int. Total
	Left	Thru	Right	Peds	Left	Thru	Right	Peds	Left	Thru	Right	Peds	Left	Thru	Right	Peds	
06:00	7	0	33	2	6	27	0	0	0	0	0	0	0	36	1	1	113
06:15	5	0	44	1	5	34	0	1	0	0	0	0	0	44	2	0	136
06:30	12	1	35	1	5	30	0	0	0	0	0	0	1	59	4	2	150
06:45	17	0	53	2	11	32	0	0	0	0	0	0	0	80	1	1	197
Total	41	1	165	6	27	123	0	1	0	0	0	0	1	219	8	4	596
07:00	20	0	57	0	4	40	0	0	0	0	0	0	0	93	5	1	220
07:15	24	0	59	2	12	51	0	0	0	0	0	0	0	95	2	0	245
07:30	23	1	57	3	7	63	0	0	0	0	0	0	0	94	2	2	252
07:45	22	1	50	1	6	68	0	0	0	0	0	1	0	95	3	0	247
Total	89	2	223	6	29	222	0	0	0	0	0	1	0	377	12	3	964
08:00	20	1	39	2	9	33	0	0	0	0	0	0	0	83	2	2	191
08:15	25	0	37	1	6	32	0	0	0	0	0	0	0	67	2	0	170
08:30	24	2	34	3	6	24	0	0	0	0	0	0	0	67	1	0	161
08:45	38	0	25	1	8	36	0	0	0	0	0	0	0	67	2	0	177
Total	107	3	135	7	29	125	0	0	0	0	0	0	0	284	7	2	699
15:00	81	0	23	1	11	30	0	0	0	0	0	0	0	77	4	1	228
15:15	63	11	32	1	30	29	4	1	0	0	0	0	0	76	5	0	252
15:30	96	1	49	0	12	26	0	0	0	0	0	0	0	88	1	0	273
15:45	102	0	51	0	12	42	0	0	0	0	0	0	0	99	2	0	308
Total	342	12	155	2	65	127	4	1	0	0	0	0	0	340	12	1	1061
16:00	94	0	50	0	11	30	0	0	0	0	0	0	0	117	3	0	305
16:15	102	0	69	2	12	35	0	0	0	0	0	0	0	119	5	0	344
16:30	101	1	70	2	11	33	1	0	0	0	0	0	1	122	3	0	345
16:45	116	0	92	0	20	25	0	0	0	0	0	0	0	122	5	1	381
Total	413	1	281	4	54	123	1	0	0	0	0	0	1	480	16	1	1375
17:00	98	2	91	2	22	31	0	0	0	0	0	0	0	132	3	2	383
17:15	93	0	86	4	20	44	0	0	0	0	0	0	0	130	3	1	381
17:30	94	0	65	2	17	53	0	0	0	0	0	0	0	119	4	0	354
17:45	96	1	59	0	13	43	0	0	0	0	0	0	0	94	3	1	310
Total	381	3	301	8	72	171	0	0	0	0	0	0	0	475	13	4	1428
Grand Total	1373	22	1260	33	276	891	5	2	0	0	0	1	2	2175	68	15	6123
Apprch %	51.1	0.8	46.9	1.2	23.5	75.9	0.4	0.2	0	0	0	100	0.1	96.2	3	0.7	
Total %	22.4	0.4	20.6	0.5	4.5	14.6	0.1	0	0	0	0	0	0	35.5	1.1	0.2	



# MINNESOTA DEPT OF TRANSPORTATION

## TRAFFIC DATA COLLECTION - METRO

TH-52 at 70th St. E/CSAH-26, W Ramps  
 Ref.Pt.: 123.505  
 JAMAR #D4-3365  
 TURN MOVEMENT COUNT

File Name : th-52 at 70th ave e csah-26 w ramp 2009  
 Site Code : 00000000  
 Start Date : 6/24/2009  
 Page No : 2

Start Time	ramp from SB TH-52 Southbound					70th St E / CSAH-26 Westbound					ramp to SB TH-52 Northbound					70th St E / CSAH-26 Eastbound					Int. Total
	Left	Thru	Right	Peds	App. Total	Left	Thru	Right	Peds	App. Total	Left	Thru	Right	Peds	App. Total	Left	Thru	Right	Peds	App. Total	
Peak Hour Analysis From 06:00 to 08:45 - Peak 1 of 1																					
Peak Hour for Entire Intersection Begins at 07:00																					
07:00	20	0	57	0	77	4	40	0	0	44	0	0	0	0	0	0	93	5	1	99	220
07:15	24	0	59	2	85	12	51	0	0	63	0	0	0	0	0	0	95	2	0	97	245
07:30	23	1	57	3	84	7	63	0	0	70	0	0	0	0	0	0	94	2	2	98	252
07:45	22	1	50	1	74	6	68	0	0	74	0	0	0	1	1	0	95	3	0	98	247
Total Volume	89	2	223	6	320	29	222	0	0	251	0	0	0	1	1	0	377	12	3	392	964
% App. Total	27.8	0.6	69.7	1.9		11.6	88.4	0	0		0	0	0	100		0	96.2	3.1	0.8		
PHF	.927	.500	.945	.500	.941	.604	.816	.000	.000	.848	.000	.000	.000	.250	.250	.000	.992	.600	.375	.990	.956

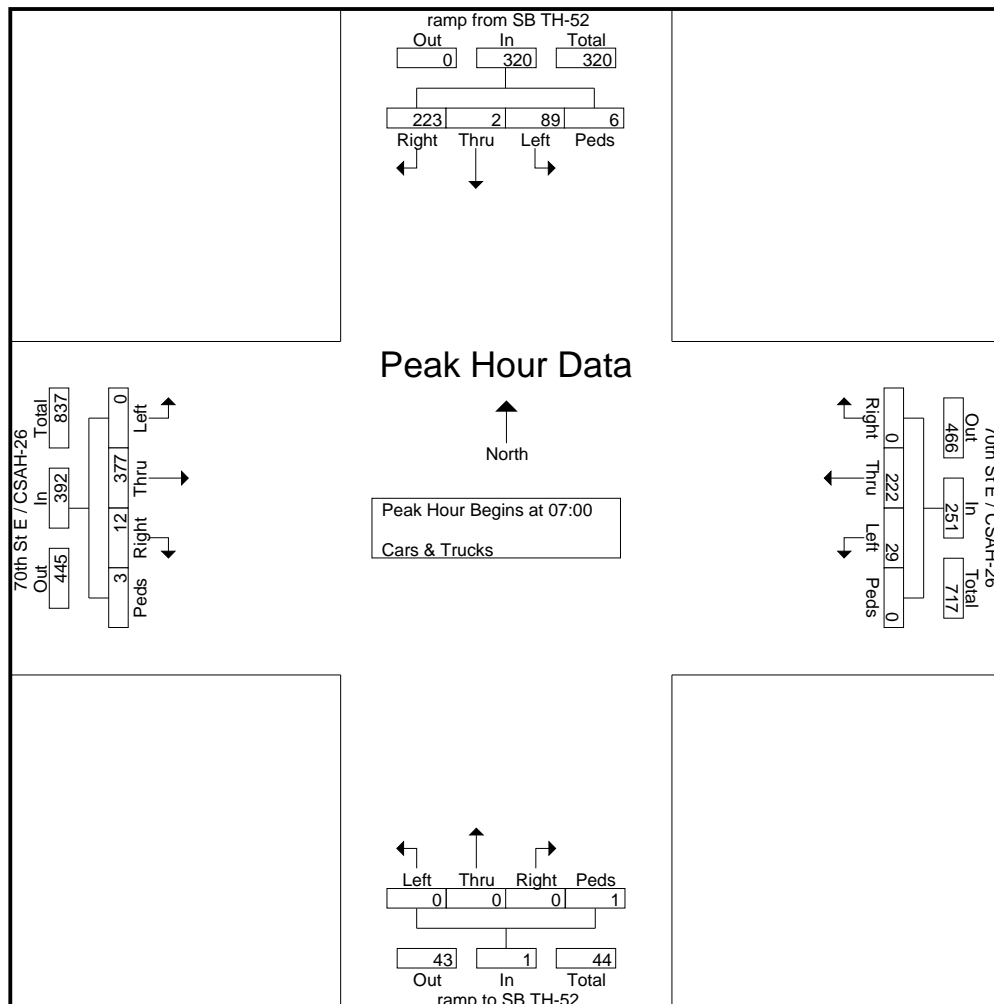



# MINNESOTA DEPT OF TRANSPORTATION

## TRAFFIC DATA COLLECTION - METRO

TH-52 at 70th St. E/CSAH-26, W Ramps  
 Ref.Pt.: 123.505  
 JAMAR #D4-3365  
 TURN MOVEMENT COUNT

File Name : th-52 at 70th ave e csah-26 w ramp 2009  
 Site Code : 00000000  
 Start Date : 6/24/2009  
 Page No : 3

Start Time	ramp from SB TH-52 Southbound					70th St E / CSAH-26 Westbound					ramp to SB TH-52 Northbound					70th St E / CSAH-26 Eastbound					Int. Total
	Left	Thru	Right	Peds	App. Total	Left	Thru	Right	Peds	App. Total	Left	Thru	Right	Peds	App. Total	Left	Thru	Right	Peds	App. Total	
Peak Hour Analysis From 15:00 to 17:45 - Peak 1 of 1																					
Peak Hour for Entire Intersection Begins at 16:45																					
16:45	116	0	92	0	208	20	25	0	0	45	0	0	0	0	0	0	122	5	1	128	381
17:00	98	2	91	2	193	22	31	0	0	53	0	0	0	0	0	0	132	3	2	137	383
17:15	93	0	86	4	183	20	44	0	0	64	0	0	0	0	0	0	130	3	1	134	381
17:30	94	0	65	2	161	17	53	0	0	70	0	0	0	0	0	0	119	4	0	123	354
Total Volume	401	2	334	8	745	79	153	0	0	232	0	0	0	0	0	0	503	15	4	522	1499
% App. Total	53.8	0.3	44.8	1.1		34.1	65.9	0	0		0	0	0	0		0	96.4	2.9	0.8		
PHF	.864	.250	.908	.500	.895	.898	.722	.000	.000	.829	.000	.000	.000	.000	.000	.000	.953	.750	.500	.953	.978

