

ALLIANT ENGINEERING, INC.

733 S Marquette Ave #700, Minneapolis, MN 55402

Intersection: Upper 55th Street & Cenex Drive - TH 52 West Ramp
 Date: 9/19/2024
 Duration: 0600-1900

Site Code: 420
 Ref Pt: N/A
 Page No: 2 of 4

All Vehicles (Cars & Trucks) Printed

Start Time	Cenex Drive Southbound						Upper 55th Street Westbound						TH 52 West Ramp Northbound						Upper 55th Street Eastbound						Int. Veh. Total	Int. Ped/Bike Total
	U-Turn	Left	Thru	Right	App. Total	Peds/Bikes	U-Turn	Left	Thru	Right	App. Total	Peds/Bikes	U-Turn	Left	Thru	Right	App. Total	Peds/Bikes	U-Turn	Left	Thru	Right	App. Total	Peds/Bikes		
7:15	--	7	3	1	11	1	--	14	42	11	67	--	--	16	27	62	105	--	--	3	37	12	52	1	235	2
7:30	--	6	--	--	6	--	--	18	63	18	99	--	--	12	37	60	109	--	--	1	69	12	82	--	296	--
7:45	--	7	2	--	9	--	--	21	54	31	106	--	--	6	38	73	117	--	--	2	50	20	72	--	304	--
8:00	--	9	1	--	10	2	--	13	39	7	59	--	--	7	38	57	102	--	1	--	37	15	53	1	224	3
Hour Total	--	29	6	1	36	3	--	66	198	67	331	--	--	41	140	252	433	--	1	6	193	59	259	2	1059	5
% of App.	0.0%	80.6%	16.7%	2.8%			0.0%	19.9%	59.8%	20.2%			0.0%	9.5%	32.3%	58.2%			0.4%	2.3%	74.5%	22.8%				
% of Total	0.0%	2.7%	0.6%	0.1%	3.4%	60.0%	0.0%	6.2%	18.7%	6.3%	31.3%	0.0%	0.0%	3.9%	13.2%	23.8%	40.9%	0.0%	0.1%	0.6%	18.2%	5.6%	24.5%	40.0%		
Cars Total	--	29	5	1	35	2	--	64	189	67	320	--	--	39	140	243	422	--	1	6	188	55	250	1	1027	3
Cars % of Movement	0.0%	100%	83.3%	100%	97.2%	66.7%	0.0%	97.0%	95.5%	100%	96.7%	0.0%	0.0%	95.1%	100%	96.4%	97.5%	0.0%	100%	100%	97.4%	93.2%	96.5%	33.3%	97.0%	
Trucks Total	--	--	1	--	1	1	--	2	9	--	11	--	--	2	--	9	11	--	--	--	5	4	9	1	32	2
Trucks % of Movement	0.0%	0.0%	16.7%	0.0%	2.8%	50.0%	0.0%	3.0%	4.5%	0.0%	3.3%	0.0%	0.0%	4.9%	0.0%	3.6%	2.5%	0.0%	0.0%	0.0%	2.6%	6.8%	3.5%	50.0%	3.0%	

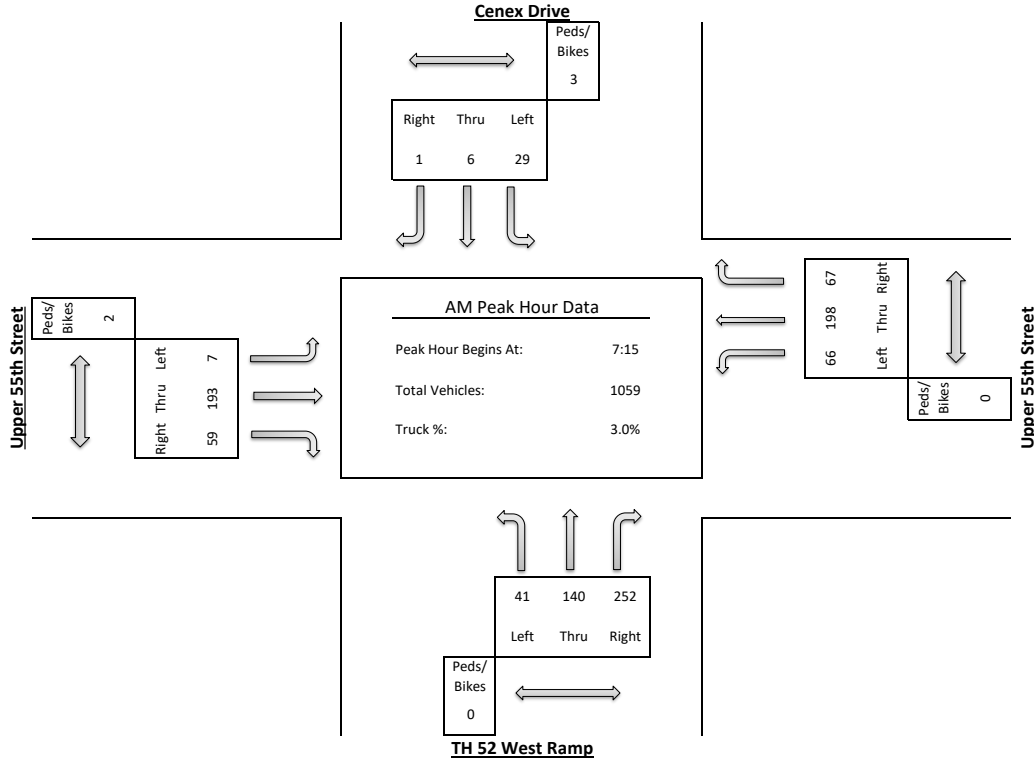

ALLIANT ENGINEERING, INC.

733 S Marquette Ave #700, Minneapolis, MN 55402

Intersection: Upper 55th Street & Cenex Drive - TH 52 West Ramp
 Date: 9/19/2024
 Duration: 0600-1900

Site Code: 420
 Ref Pt: N/A
 Page No: 3 of 4

All Vehicles (Cars & Trucks) Printed

Start Time	Cenex Drive Southbound						Upper 55th Street Westbound						TH 52 West Ramp Northbound						Upper 55th Street Eastbound						Int. Veh. Total	Int. Ped/Bike Total
	U-Turn	Left	Thru	Right	App. Total	Peds/Bikes	U-Turn	Left	Thru	Right	App. Total	Peds/Bikes	U-Turn	Left	Thru	Right	App. Total	Peds/Bikes	U-Turn	Left	Thru	Right	App. Total	Peds/Bikes		
12:00	--	13	2	2	17	1	--	14	50	7	71	--	1	12	8	63	84	--	--	2	56	4	62	3	234	4
12:15	--	16	1	1	18	2	--	14	47	16	77	--	--	5	6	75	86	--	--	--	64	1	65	2	246	4
12:30	--	6	1	--	7	2	--	13	48	5	66	--	--	9	13	68	90	--	1	1	57	5	64	2	227	4
12:45	--	11	1	2	14	2	--	18	43	8	69	--	--	11	12	83	106	--	1	2	56	10	69	1	258	3
Hour Total	--	46	5	5	56	7	--	59	188	36	283	--	1	37	39	289	366	--	2	5	233	20	260	8	965	15
% of App.	0.0%	82.1%	8.9%	8.9%			0.0%	20.8%	66.4%	12.7%			0.3%	10.1%	10.7%	79.0%			0.8%	1.9%	89.6%	7.7%				
% of Total	0.0%	4.8%	0.5%	0.5%	5.8%	46.7%	0.0%	6.1%	19.5%	3.7%	29.3%	0.0%	0.1%	3.8%	4.0%	29.9%	37.9%	0.0%	0.2%	0.5%	24.1%	2.1%	26.9%	53.3%		
Cars Total	--	46	5	5	56	5	--	57	185	36	278	--	1	37	39	272	349	--	2	5	231	18	256	8	939	13
Cars % of Movement	0.0%	100%	100%	100%	100%	38.5%	0.0%	96.6%	98.4%	100%	98.2%	0.0%	100%	100%	100%	94.1%	95.4%	0.0%	100%	100%	99.1%	90.0%	98.5%	61.5%	97.3%	
Trucks Total	--	--	--	--	0	2	--	2	3	--	5	--	--	--	--	17	17	--	--	--	2	2	4	--	26	2
Trucks % of Movement	0.0%	0.0%	0.0%	0.0%	0.0%	100.0%	0.0%	3.4%	1.6%	0.0%	1.8%	0.0%	0.0%	0.0%	0.0%	5.9%	4.6%	0.0%	0.0%	0.0%	0.9%	10.0%	1.5%	0.0%	2.7%	

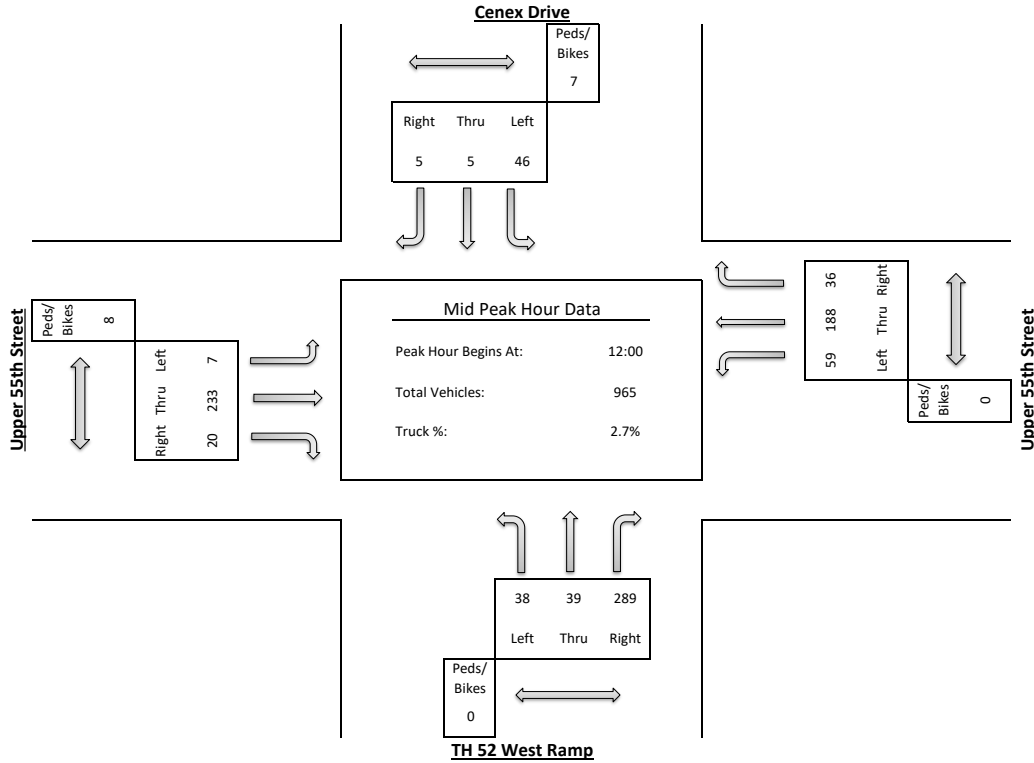

ALLIANT ENGINEERING, INC.

733 S Marquette Ave #700, Minneapolis, MN 55402

Intersection: Upper 55th Street & Cenex Drive - TH 52 West Ramp
 Date: 9/19/2024
 Duration: 0600-1900

Site Code: 420
 Ref Pt: N/A
 Page No: 4 of 4

All Vehicles (Cars & Trucks) Printed

Start Time	Cenex Drive Southbound						Upper 55th Street Westbound						TH 52 West Ramp Northbound						Upper 55th Street Eastbound						Int. Veh. Total	Int. Ped/Bike Total
	U-Turn	Left	Thru	Right	App. Total	Peds/Bikes	U-Turn	Left	Thru	Right	App. Total	Peds/Bikes	U-Turn	Left	Thru	Right	App. Total	Peds/Bikes	U-Turn	Left	Thru	Right	App. Total	Peds/Bikes		
16:00	--	29	5	4	38	--	1	19	62	11	93	--	--	21	11	95	127	--	--	1	75	16	92	--	350	--
16:15	--	35	8	1	44	1	--	21	46	9	76	--	--	15	7	118	140	--	--	1	84	14	99	3	359	4
16:30	--	33	10	2	45	--	--	16	49	5	70	--	1	18	8	98	125	--	--	--	86	6	92	--	332	--
16:45	--	18	9	3	30	3	1	21	45	10	77	--	--	25	12	107	144	--	2	--	89	8	99	--	350	3
Hour Total	--	115	32	10	157	4	2	77	202	35	316	--	1	79	38	418	536	--	2	2	334	44	382	3	1391	7
% of App.	0.0%	73.2%	20.4%	6.4%			0.6%	24.4%	63.9%	11.1%			0.2%	14.7%	7.1%	78.0%			0.5%	0.5%	87.4%	11.5%				
% of Total	0.0%	8.3%	2.3%	0.7%	11.3%	57.1%	0.1%	5.5%	14.5%	2.5%	22.7%	0.0%	0.1%	5.7%	2.7%	30.1%	38.5%	0.0%	0.1%	0.1%	24.0%	3.2%	27.5%	42.9%		
Cars Total	--	114	32	10	156	2	2	76	199	34	311	--	1	79	37	407	524	--	2	2	333	42	379	1	1370	3
Cars % of Movement	0.0%	99.1%	100%	100%	99.4%	66.7%	100%	98.7%	98.5%	97.1%	98.4%	0.0%	100%	100%	97.4%	97.4%	97.8%	0.0%	100%	100%	99.7%	95.5%	99.2%	33.3%	98.5%	
Trucks Total	--	1	--	--	1	2	--	1	3	1	5	--	--	--	1	11	12	--	--	--	1	2	3	2	21	4
Trucks % of Movement	0.0%	0.9%	0.0%	0.0%	0.6%	50.0%	0.0%	1.3%	1.5%	2.9%	1.6%	0.0%	0.0%	0.0%	2.6%	2.6%	2.2%	0.0%	0.0%	0.0%	0.3%	4.5%	0.8%	50.0%	1.5%	

