



# MINNESOTA DEPT OF TRANSPORTATION

## TRAFFIC DATA COLLECTION - METRO

I-394 at Louisiana Ave., North Ramps  
 REF.PT.: 004.455  
 JAMAR # 632/631` DR/ RE  
 TURN MOVEMENT COUNT

File Name : I-394 AT LOUISIANA AVE N RAMP 2007 AMPM  
 Site Code : 00000000  
 Start Date : 4/19/2007  
 Page No : 1

### Groups Printed- Cars & Trucks

Start Time	LOUISIANA AVE Southbound				RAMP FROM I-394 WB Westbound				LOUISIANA AVE Northbound				RAMP TO I-394 WB Eastbound				Int. Total
	Left	Thru	Right	Peds	Left	Thru	Right	Peds	Left	Thru	Right	Peds	Left	Thru	Right	Peds	
06:00	0	16	6	0	30	1	24	0	14	23	0	0	0	0	0	0	114
06:15	0	17	9	0	36	0	15	0	23	33	0	0	0	0	0	0	133
06:30	0	24	16	0	34	2	32	0	32	48	0	0	0	0	0	0	188
06:45	0	28	18	0	62	0	44	0	43	58	0	1	0	0	0	0	254
Total	0	85	49	0	162	3	115	0	112	162	0	1	0	0	0	0	689
07:00	0	35	21	2	43	0	44	0	44	85	0	0	0	0	0	0	274
07:15	0	30	33	2	64	0	52	0	53	78	0	3	0	0	0	0	315
07:30	0	54	36	1	57	0	43	0	83	95	0	1	0	0	0	0	370
07:45	0	62	28	0	49	1	50	0	92	100	0	0	0	0	0	0	382
Total	0	181	118	5	213	1	189	0	272	358	0	4	0	0	0	0	1341
08:00	0	45	41	0	55	0	50	0	79	130	0	0	0	0	0	0	400
08:15	0	46	37	1	59	0	54	0	69	106	0	0	0	0	0	0	372
08:30	0	52	50	0	71	0	66	0	53	95	0	2	0	0	0	0	389
08:45	0	56	46	0	53	2	65	0	48	111	0	0	0	0	0	0	381
Total	0	199	174	1	238	2	235	0	249	442	0	2	0	0	0	0	1542
*** BREAK ***																	
15:00	0	107	100	0	65	0	58	0	69	108	0	0	0	0	0	0	507
15:15	0	79	85	1	53	1	48	0	73	92	0	0	0	0	0	0	432
15:30	0	84	90	1	76	0	3	0	77	95	0	0	0	0	0	0	426
15:45	0	65	70	0	78	0	3	0	69	111	0	0	0	0	0	0	396
Total	0	335	345	2	272	1	112	0	288	406	0	0	0	0	0	0	1761
16:00	0	84	92	1	64	1	50	0	72	103	0	0	0	0	0	0	467
16:15	0	70	91	1	85	0	51	0	90	131	0	0	0	0	0	0	519
16:30	0	73	73	1	70	1	58	0	109	135	0	2	0	0	0	0	522
16:45	0	83	83	0	83	3	70	0	82	144	0	0	0	0	0	0	548
Total	0	310	339	3	302	5	229	0	353	513	0	2	0	0	0	0	2056
17:00	0	102	98	1	89	1	74	0	120	125	0	0	0	0	0	0	610
17:15	0	84	82	1	110	3	64	0	106	165	0	1	0	0	0	0	616
17:30	0	105	102	3	112	2	80	1	71	149	0	0	0	0	0	0	625
17:45	0	80	61	1	106	1	65	0	106	123	0	0	0	0	0	0	543
Total	0	371	343	6	417	7	283	1	403	562	0	1	0	0	0	0	2394
Grand Total	0	1481	1368	17	1604	19	1163	1	1677	2443	0	10	0	0	0	0	9783
Apprch %	0	51.7	47.7	0.6	57.6	0.7	41.7	0	40.6	59.2	0	0.2	0	0	0	0	
Total %	0	15.1	14	0.2	16.4	0.2	11.9	0	17.1	25	0	0.1	0	0	0	0	



# MINNESOTA DEPT OF TRANSPORTATION

TRAFFIC DATA COLLECTION - METRO

I-394 at Louisiana Ave., North Ramps  
 REF.PT.: 004.455  
 JAMAR # 632/631` DR/ RE  
 TURN MOVEMENT COUNT

File Name : I-394 AT LOUISIANA AVE N RAMP 2007 AMPM  
 Site Code : 00000000  
 Start Date : 4/19/2007  
 Page No : 2

Start Time	LOUISIANA AVE Southbound					RAMP FROM I-394 WB Westbound					LOUISIANA AVE Northbound					RAMP TO I-394 WB Eastbound					Int. Total
	Left	Thru	Right	Peds	App. Total	Left	Thru	Right	Peds	App. Total	Left	Thru	Right	Peds	App. Total	Left	Thru	Right	Peds	App. Total	
Peak Hour Analysis From 06:00 to 08:45 - Peak 1 of 1																					
Peak Hour for Entire Intersection Begins at 07:45																					
07:45	0	62	28	0	90	49	1	50	0	100	92	100	0	0	192	0	0	0	0	0	382
08:00	0	45	41	0	86	55	0	50	0	105	79	130	0	0	209	0	0	0	0	0	400
08:15	0	46	37	1	84	59	0	54	0	113	69	106	0	0	175	0	0	0	0	0	372
08:30	0	52	50	0	102	71	0	66	0	137	53	95	0	2	150	0	0	0	0	0	389
Total Volume	0	205	156	1	362	234	1	220	0	455	293	431	0	2	726	0	0	0	0	0	1543
% App. Total																					
PHF	.000	.827	.780	.250	.887	.824	.250	.833	.000	.830	.796	.829	.000	.250	.868	.000	.000	.000	.000	.000	.964

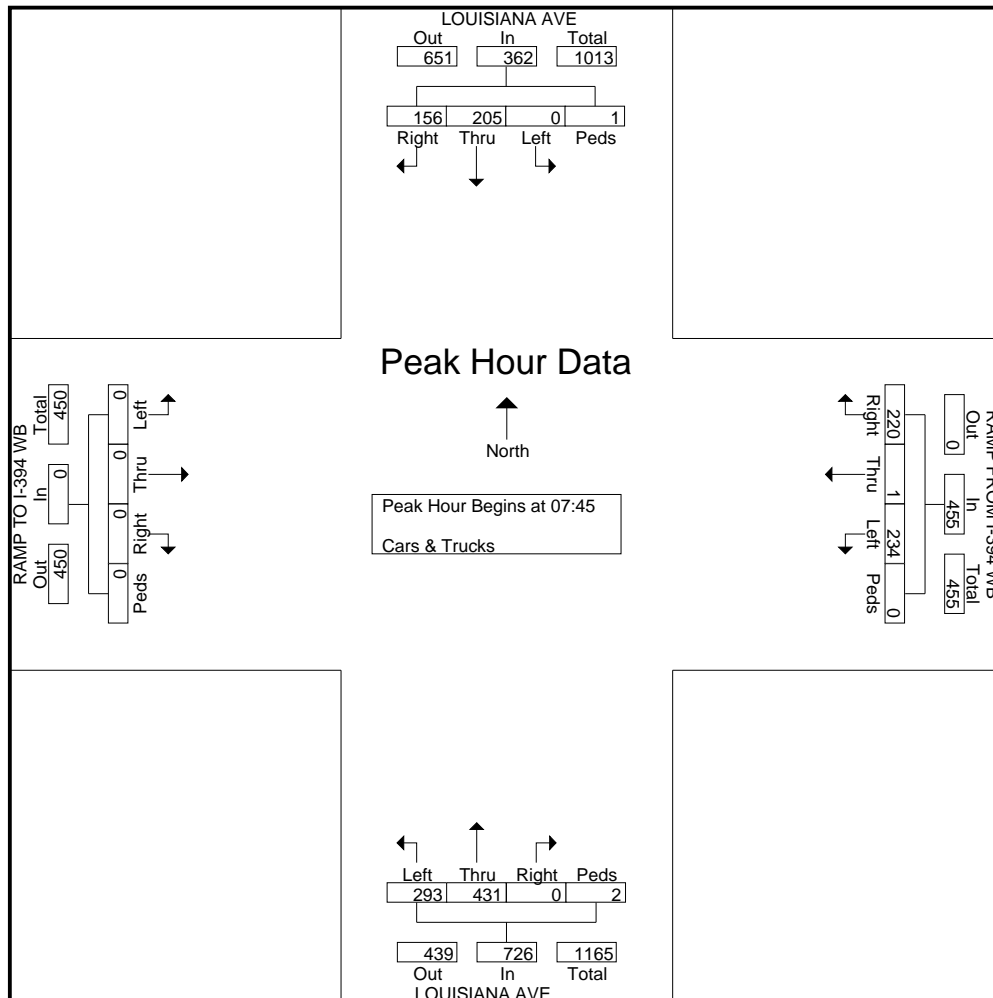



# MINNESOTA DEPT OF TRANSPORTATION

## TRAFFIC DATA COLLECTION - METRO

I-394 at Louisiana Ave., North Ramps  
 REF.PT.: 004.455  
 JAMAR # 632/631` DR/ RE  
 TURN MOVEMENT COUNT

File Name : I-394 AT LOUISIANA AVE N RAMP 2007 AMPM  
 Site Code : 00000000  
 Start Date : 4/19/2007  
 Page No : 3

Start Time	LOUISIANA AVE Southbound					RAMP FROM I-394 WB Westbound					LOUISIANA AVE Northbound					RAMP TO I-394 WB Eastbound					Int. Total
	Left	Thru	Right	Peds	App. Total	Left	Thru	Right	Peds	App. Total	Left	Thru	Right	Peds	App. Total	Left	Thru	Right	Peds	App. Total	
Peak Hour Analysis From 15:00 to 17:45 - Peak 1 of 1																					
Peak Hour for Entire Intersection Begins at 16:45																					
16:45	0	83	83	0	166	83	3	70	0	156	82	144	0	0	226	0	0	0	0	0	548
17:00	0	102	98	1	201	89	1	74	0	164	120	125	0	0	245	0	0	0	0	0	610
17:15	0	84	82	1	167	110	3	64	0	177	106	165	0	1	272	0	0	0	0	0	616
17:30	0	105	102	3	210	112	2	80	1	195	71	149	0	0	220	0	0	0	0	0	625
Total Volume	0	374	365	5	744	394	9	288	1	692	379	583	0	1	963	0	0	0	0	0	2399
% App. Total																					
PHF	.000	.890	.895	.417	.886	.879	.750	.900	.250	.887	.790	.883	.000	.250	.885	.000	.000	.000	.000	.000	.960

