



MINNESOTA DEPT OF TRANSPORTATION

TRAFFIC DATA COLLECTION - METRO

LYNDALE AVE AT 76TH ST (N OF I-494)

REF.PT.:

JAMAR# 631 RE

TURN MOVEMENT COUNT

File Name : LYNDALE AVE AT 76TH ST 2006

Site Code : 00000000

Start Date : 2/14/2006

Page No : 1

Groups Printed- Cars & Trucks

| Start Time | LYNDALE AVE. Southbound | | | | 76th ST. Westbound | | | | LYNDALE AVE. Northbound | | | | 76th ST. Eastbound | | | | Int. Total |
|-------------|----------------------------|------|-------|------|-----------------------|------|-------|------|----------------------------|------|-------|------|-----------------------|------|-------|------|------------|
| | Left | Thru | Right | Peds | Left | Thru | Right | Peds | Left | Thru | Right | Peds | Left | Thru | Right | Peds | |
| 06:00 | 0 | 20 | 4 | 1 | 4 | 3 | 1 | 1 | 1 | 15 | 5 | 0 | 7 | 2 | 3 | 0 | 67 |
| 06:15 | 4 | 29 | 2 | 1 | 4 | 3 | 4 | 0 | 3 | 29 | 2 | 0 | 3 | 3 | 4 | 1 | 92 |
| 06:30 | 2 | 34 | 13 | 1 | 6 | 11 | 1 | 0 | 4 | 26 | 4 | 0 | 10 | 4 | 10 | 0 | 126 |
| 06:45 | 2 | 52 | 21 | 1 | 5 | 16 | 2 | 0 | 3 | 32 | 6 | 0 | 9 | 13 | 8 | 0 | 170 |
| Total | 8 | 135 | 40 | 4 | 19 | 33 | 8 | 1 | 11 | 102 | 17 | 0 | 29 | 22 | 25 | 1 | 455 |
| 07:00 | 2 | 44 | 14 | 0 | 5 | 14 | 1 | 0 | 3 | 31 | 1 | 2 | 14 | 19 | 9 | 1 | 160 |
| 07:15 | 4 | 55 | 17 | 2 | 7 | 38 | 4 | 0 | 3 | 62 | 11 | 0 | 7 | 13 | 11 | 1 | 235 |
| 07:30 | 4 | 81 | 34 | 2 | 7 | 48 | 7 | 1 | 5 | 49 | 4 | 0 | 9 | 22 | 10 | 0 | 283 |
| 07:45 | 5 | 98 | 33 | 0 | 11 | 45 | 13 | 0 | 5 | 59 | 5 | 0 | 39 | 29 | 5 | 0 | 347 |
| Total | 15 | 278 | 98 | 4 | 30 | 145 | 25 | 1 | 16 | 201 | 21 | 2 | 69 | 83 | 35 | 2 | 1025 |
| 08:00 | 6 | 105 | 27 | 1 | 13 | 30 | 9 | 1 | 6 | 49 | 4 | 0 | 19 | 9 | 9 | 1 | 289 |
| 08:15 | 2 | 57 | 19 | 0 | 10 | 30 | 2 | 0 | 3 | 54 | 9 | 0 | 8 | 15 | 6 | 0 | 215 |
| 08:30 | 3 | 54 | 11 | 1 | 6 | 32 | 8 | 0 | 3 | 54 | 3 | 3 | 8 | 11 | 5 | 0 | 202 |
| 08:45 | 3 | 71 | 14 | 0 | 7 | 22 | 5 | 0 | 1 | 67 | 9 | 0 | 14 | 17 | 9 | 0 | 239 |
| Total | 14 | 287 | 71 | 2 | 36 | 114 | 24 | 1 | 13 | 224 | 25 | 3 | 49 | 52 | 29 | 1 | 945 |
| 10:30 | 1 | 73 | 11 | 1 | 7 | 12 | 3 | 1 | 3 | 51 | 8 | 2 | 8 | 10 | 4 | 0 | 195 |
| 10:45 | 3 | 71 | 10 | 0 | 10 | 11 | 6 | 1 | 6 | 71 | 9 | 2 | 7 | 12 | 3 | 0 | 222 |
| Total | 4 | 144 | 21 | 1 | 17 | 23 | 9 | 2 | 9 | 122 | 17 | 4 | 15 | 22 | 7 | 0 | 417 |
| 11:00 | 5 | 57 | 19 | 1 | 7 | 8 | 6 | 0 | 6 | 76 | 9 | 1 | 12 | 10 | 7 | 0 | 224 |
| 11:15 | 3 | 70 | 9 | 0 | 4 | 9 | 7 | 0 | 5 | 69 | 7 | 0 | 15 | 19 | 6 | 0 | 223 |
| 11:30 | 10 | 83 | 14 | 0 | 9 | 23 | 10 | 0 | 6 | 99 | 12 | 0 | 18 | 12 | 10 | 0 | 306 |
| 11:45 | 4 | 80 | 15 | 0 | 9 | 15 | 6 | 0 | 10 | 89 | 5 | 0 | 28 | 26 | 8 | 0 | 295 |
| Total | 22 | 290 | 57 | 1 | 29 | 55 | 29 | 0 | 27 | 333 | 33 | 1 | 73 | 67 | 31 | 0 | 1048 |
| 12:00 | 4 | 93 | 19 | 2 | 7 | 18 | 14 | 1 | 10 | 80 | 13 | 1 | 13 | 10 | 9 | 1 | 295 |
| 12:15 | 11 | 89 | 11 | 1 | 10 | 17 | 12 | 0 | 5 | 79 | 14 | 0 | 17 | 22 | 12 | 0 | 300 |
| 12:30 | 6 | 99 | 21 | 0 | 20 | 19 | 10 | 0 | 7 | 83 | 21 | 2 | 17 | 22 | 15 | 2 | 344 |
| 12:45 | 9 | 93 | 19 | 0 | 10 | 16 | 3 | 0 | 8 | 90 | 9 | 2 | 13 | 18 | 13 | 1 | 304 |
| Total | 30 | 374 | 70 | 3 | 47 | 70 | 39 | 1 | 30 | 332 | 57 | 5 | 60 | 72 | 49 | 4 | 1243 |
| 15:00 | 6 | 98 | 18 | 1 | 6 | 24 | 3 | 0 | 3 | 75 | 8 | 3 | 14 | 25 | 13 | 2 | 299 |
| 15:15 | 9 | 80 | 18 | 1 | 12 | 23 | 6 | 1 | 7 | 107 | 6 | 1 | 17 | 19 | 4 | 0 | 311 |
| 15:30 | 9 | 105 | 21 | 2 | 16 | 21 | 10 | 0 | 5 | 95 | 3 | 0 | 21 | 31 | 2 | 3 | 344 |
| 15:45 | 9 | 96 | 25 | 0 | 9 | 22 | 6 | 1 | 13 | 123 | 13 | 2 | 31 | 25 | 12 | 0 | 387 |
| Total | 33 | 379 | 82 | 4 | 43 | 90 | 25 | 2 | 28 | 400 | 30 | 6 | 83 | 100 | 31 | 5 | 1341 |
| 16:00 | 14 | 112 | 23 | 0 | 12 | 18 | 8 | 1 | 6 | 123 | 9 | 2 | 26 | 21 | 12 | 0 | 387 |
| 16:15 | 10 | 72 | 22 | 0 | 12 | 27 | 8 | 0 | 5 | 126 | 11 | 0 | 26 | 31 | 9 | 0 | 359 |
| 16:30 | 13 | 108 | 21 | 4 | 10 | 24 | 10 | 3 | 9 | 114 | 9 | 0 | 24 | 38 | 9 | 3 | 399 |
| 16:45 | 9 | 110 | 22 | 0 | 17 | 38 | 8 | 0 | 19 | 103 | 6 | 2 | 35 | 31 | 7 | 0 | 407 |
| Total | 46 | 402 | 88 | 4 | 51 | 107 | 34 | 4 | 39 | 466 | 35 | 4 | 111 | 121 | 37 | 3 | 1552 |
| 17:00 | 10 | 133 | 15 | 5 | 14 | 28 | 12 | 1 | 10 | 156 | 16 | 3 | 36 | 42 | 5 | 1 | 487 |
| 17:15 | 10 | 101 | 13 | 5 | 14 | 29 | 9 | 0 | 7 | 139 | 9 | 4 | 34 | 46 | 7 | 0 | 427 |
| 17:30 | 7 | 124 | 19 | 0 | 13 | 20 | 13 | 0 | 9 | 124 | 16 | 1 | 23 | 51 | 12 | 0 | 432 |
| 17:45 | 10 | 98 | 21 | 3 | 9 | 21 | 5 | 0 | 12 | 129 | 9 | 0 | 12 | 32 | 13 | 0 | 374 |
| Total | 37 | 456 | 68 | 13 | 50 | 98 | 39 | 1 | 38 | 548 | 50 | 8 | 105 | 171 | 37 | 1 | 1720 |
| Grand Total | 209 | 2745 | 595 | 36 | 322 | 735 | 232 | 13 | 211 | 2728 | 285 | 33 | 594 | 710 | 281 | 17 | 9746 |
| Apprch % | 5.8 | 76.6 | 16.6 | 1 | 24.7 | 56.5 | 17.8 | 1 | 6.5 | 83.8 | 8.8 | 1 | 37.1 | 44.3 | 17.5 | 1.1 | |
| Total % | 2.1 | 28.2 | 6.1 | 0.4 | 3.3 | 7.5 | 2.4 | 0.1 | 2.2 | 28 | 2.9 | 0.3 | 6.1 | 7.3 | 2.9 | 0.2 | |



MINNESOTA DEPT OF TRANSPORTATION

TRAFFIC DATA COLLECTION - METRO

LYNDALE AVE AT 76TH ST (N OF I-494)

REF.PT.:

JAMAR# 631 RE

TURN MOVEMENT COUNT

File Name : LYNDALE AVE AT 76TH ST 2006

Site Code : 00000000

Start Date : 2/14/2006

Page No : 3

| Start Time | LYNDALE AVE. Southbound | | | | | 76th ST. Westbound | | | | | LYNDALE AVE. Northbound | | | | | 76th ST. Eastbound | | | | | Int. Total |
|--|-------------------------|------|-------|------|------------|--------------------|------|-------|------|------------|-------------------------|------|-------|------|------------|--------------------|------|-------|------|------------|------------|
| | Left | Thru | Right | Peds | App. Total | Left | Thru | Right | Peds | App. Total | Left | Thru | Right | Peds | App. Total | Left | Thru | Right | Peds | App. Total | |
| Peak Hour Analysis From 06:00 to 08:45 - Peak 1 of 1 | | | | | | | | | | | | | | | | | | | | | |
| Peak Hour for Entire Intersection Begins at 07:15 | | | | | | | | | | | | | | | | | | | | | |
| 07:15 | 4 | 55 | 17 | 2 | 78 | 7 | 38 | 4 | 0 | 49 | 3 | 62 | 11 | 0 | 76 | 7 | 13 | 11 | 1 | 32 | 235 |
| 07:30 | 4 | 81 | 34 | 2 | 121 | 7 | 48 | 7 | 1 | 63 | 5 | 49 | 4 | 0 | 58 | 9 | 22 | 10 | 0 | 41 | 283 |
| 07:45 | 5 | 98 | 33 | 0 | 136 | 11 | 45 | 13 | 0 | 69 | 5 | 59 | 5 | 0 | 69 | 39 | 29 | 5 | 0 | 73 | 347 |
| 08:00 | 6 | 105 | 27 | 1 | 139 | 13 | 30 | 9 | 1 | 53 | 6 | 49 | 4 | 0 | 59 | 19 | 9 | 9 | 1 | 38 | 289 |
| Total Volume | 19 | 339 | 111 | 5 | 474 | 38 | 161 | 33 | 2 | 234 | 19 | 219 | 24 | 0 | 262 | 74 | 73 | 35 | 2 | 184 | 1154 |
| % App. Total | 4 | 71.5 | 23.4 | 1.1 | | 16.2 | 68.8 | 14.1 | 0.9 | | 7.3 | 83.6 | 9.2 | 0 | | 40.2 | 39.7 | 19 | 1.1 | | |
| PHF | .792 | .807 | .816 | .625 | .853 | .731 | .839 | .635 | .500 | .848 | .792 | .883 | .545 | .000 | .862 | .474 | .629 | .795 | .500 | .630 | .831 |

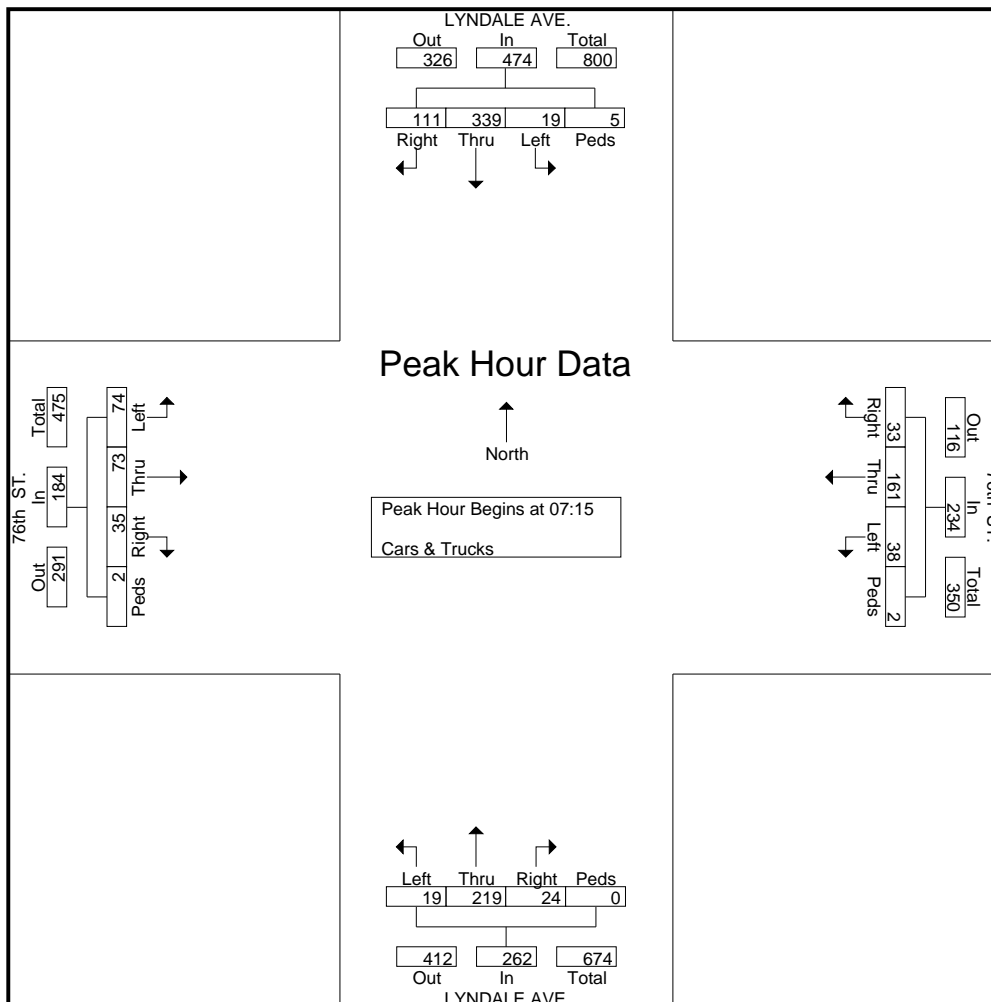



MINNESOTA DEPT OF TRANSPORTATION

TRAFFIC DATA COLLECTION - METRO

LYNDALE AVE AT 76TH ST (N OF I-494)

REF.PT.:

JAMAR# 631 RE

TURN MOVEMENT COUNT

File Name : LYNDALE AVE AT 76TH ST 2006

Site Code : 00000000

Start Date : 2/14/2006

Page No : 4

| Start Time | LYNDALE AVE. Southbound | | | | | 76th ST. Westbound | | | | | LYNDALE AVE. Northbound | | | | | 76th ST. Eastbound | | | | | Int. Total |
|--------------|-------------------------|------|-------|------|------------|--------------------|------|-------|------|------------|-------------------------|------|-------|------|------------|--------------------|------|-------|------|------------|------------|
| | Left | Thru | Right | Peds | App. Total | Left | Thru | Right | Peds | App. Total | Left | Thru | Right | Peds | App. Total | Left | Thru | Right | Peds | App. Total | |
| 16:45 | 9 | 110 | 22 | 0 | 141 | 17 | 38 | 8 | 0 | 63 | 19 | 103 | 6 | 2 | 130 | 35 | 31 | 7 | 0 | 73 | 407 |
| 17:00 | 10 | 133 | 15 | 5 | 163 | 14 | 28 | 12 | 1 | 55 | 10 | 156 | 16 | 3 | 185 | 36 | 42 | 5 | 1 | 84 | 487 |
| 17:15 | 10 | 101 | 13 | 5 | 129 | 14 | 29 | 9 | 0 | 52 | 7 | 139 | 9 | 4 | 159 | 34 | 46 | 7 | 0 | 87 | 427 |
| 17:30 | 7 | 124 | 19 | 0 | 150 | 13 | 20 | 13 | 0 | 46 | 9 | 124 | 16 | 1 | 150 | 23 | 51 | 12 | 0 | 86 | 432 |
| Total Volume | 36 | 468 | 69 | 10 | 583 | 58 | 115 | 42 | 1 | 216 | 45 | 522 | 47 | 10 | 624 | 128 | 170 | 31 | 1 | 330 | 1753 |
| % App. Total | 6.2 | 80.3 | 11.8 | 1.7 | | 26.9 | 53.2 | 19.4 | 0.5 | | 7.2 | 83.7 | 7.5 | 1.6 | | 38.8 | 51.5 | 9.4 | 0.3 | | |
| PHF | .900 | .880 | .784 | .500 | .894 | .853 | .757 | .808 | .250 | .857 | .592 | .837 | .734 | .625 | .843 | .889 | .833 | .646 | .250 | .948 | .900 |

Peak Hour Analysis From 15:00 to 17:45 - Peak 1 of 1
 Peak Hour for Entire Intersection Begins at 16:45

