

Albeck Gerken, Inc

Transportation Engineers

Traffic Data Collection

TH-47 / University Ave at I-694, S ramps

File Name : TH-47 at I-694 South ramps 2008

Ref. Pt.: 007.528

Site Code : 01828161

Data by: Albeck Gerken Inc

Start Date : 7/10/2008

TURN MOVEMENT COUNT

Page No : 1

Groups Printed- Unshifted

Start Time	TH-47 / University Ave Southbound				ramp to EB I-694 Westbound				TH-47 / University Ave Northbound				ramp from EB I-694 Eastbound				Int. Total
	Left	Thru	Right	Peds	Left	Thru	Right	Peds	Left	Thru	Free Right	Peds	Left	Thru	Free Right	Peds	
06:00	26	121	0	0	0	0	0	0	0	89	19	0	61	0	40	0	356
06:15	36	156	0	0	0	0	0	0	0	94	31	0	72	0	51	0	440
06:30	48	230	0	0	0	0	0	0	0	125	42	0	96	0	75	0	616
06:45	47	246	0	0	0	0	0	0	0	125	32	0	129	0	85	0	664
Total	157	753	0	0	0	0	0	0	0	433	124	0	358	0	251	0	2076
07:00	44	186	0	0	0	0	0	0	0	117	39	0	98	0	66	0	550
07:15	40	239	0	0	0	0	0	0	0	120	50	0	110	0	65	0	624
07:30	56	227	0	0	0	0	0	0	0	166	45	0	114	0	82	0	690
07:45	34	206	0	0	0	0	0	0	0	147	34	0	148	1	122	1	693
Total	174	858	0	0	0	0	0	0	0	550	168	0	470	1	335	1	2557
08:00	46	147	0	0	0	0	0	0	0	124	36	0	119	0	69	1	542
08:15	39	154	0	0	0	0	0	0	0	135	40	0	113	1	65	0	547
08:30	35	115	0	0	0	0	0	0	0	149	28	0	79	0	66	0	472
08:45	45	140	0	0	0	0	0	0	0	119	30	0	112	0	70	0	516
Total	165	556	0	0	0	0	0	0	0	527	134	0	423	1	270	1	2077
*** BREAK ***																	
11:00	64	106	0	0	0	0	0	1	0	135	25	0	109	0	61	1	502
11:15	59	103	0	0	0	0	0	0	0	142	21	0	158	0	86	1	570
11:30	62	104	0	0	0	0	0	1	0	159	39	0	126	0	67	0	558
11:45	67	119	0	0	0	0	0	0	0	133	34	0	150	0	81	0	584
Total	252	432	0	0	0	0	0	2	0	569	119	0	543	0	295	2	2214
12:00	65	102	0	0	0	0	0	0	0	163	29	0	139	0	83	0	581
12:15	66	124	0	0	0	0	0	0	0	155	37	0	136	3	85	0	606
12:30	67	128	0	0	0	0	0	0	0	146	36	1	149	0	85	0	612
12:45	66	130	0	0	0	0	0	0	0	174	36	0	130	2	101	0	639
Total	264	484	0	0	0	0	0	0	0	638	138	1	554	5	354	0	2438
*** BREAK ***																	
15:00	67	108	0	0	0	0	0	0	0	181	56	0	155	0	118	0	685
15:15	53	124	0	0	0	0	0	0	0	200	45	1	171	1	118	1	714
15:30	80	110	0	0	0	0	0	0	0	239	78	0	229	1	122	0	859
15:45	61	120	0	0	0	0	0	0	0	283	40	0	181	0	127	0	812
Total	261	462	0	0	0	0	0	0	0	903	219	1	736	2	485	1	3070
16:00	32	121	0	0	0	0	0	0	0	258	45	0	215	1	119	0	791
16:15	54	143	0	0	0	0	0	0	0	260	57	0	147	0	105	0	766
16:30	72	133	0	0	0	0	0	1	0	314	70	0	191	0	116	0	897
16:45	47	129	0	0	0	0	0	1	0	315	51	0	178	0	113	1	835
Total	205	526	0	0	0	0	0	2	0	1147	223	0	731	1	453	1	3289
17:00	57	131	0	0	0	0	0	0	0	281	57	0	169	1	117	0	813
17:15	38	130	0	0	0	0	0	0	0	311	58	0	187	0	113	0	837
17:30	55	118	0	0	0	0	0	1	0	274	47	0	177	1	101	1	775
17:45	42	127	0	0	0	0	0	2	0	234	31	0	192	0	118	1	747
Total	192	506	0	0	0	0	0	3	0	1100	193	0	725	2	449	2	3172
Grand Total	1670	4577	0	0	0	0	0	7	0	5867	1318	2	4540	12	2892	8	20893
Apprch %	26.7	73.3	0	0	0	0	0	100	0	81.6	18.3	0	60.9	0.2	38.8	0.1	
Total %	8	21.9	0	0	0	0	0	0	0	28.1	6.3	0	21.7	0.1	13.8	0	

Albeck Gerken, Inc

Transportation Engineers

Traffic Data Collection

TH-47 / University Ave at I-694, S ramps

Ref. Pt.: 007.528

Data by: Albeck Gerken Inc

TURN MOVEMENT COUNT

File Name : TH-47 at I-694 South ramps 2008

Site Code : 01828161

Start Date : 7/10/2008

Page No : 2

Start Time	TH-47 / University Ave Southbound					ramp to EB I-694 Westbound					TH-47 / University Ave Northbound					ramp from EB I-694 Eastbound					Int. Total
	Left	Thru	Right	Peds	App. Total	Left	Thru	Right	Peds	App. Total	Left	Thru	Free Right	Peds	App. Total	Left	Thru	Free Right	Peds	App. Total	
Peak Hour Analysis From 06:00 to 08:45 - Peak 1 of 1																					
Peak Hour for Entire Intersection Begins at 07:00																					
07:00	44	186	0	0	230	0	0	0	0	0	0	117	39	0	156	98	0	66	0	164	550
07:15	40	239	0	0	279	0	0	0	0	0	0	120	50	0	170	110	0	65	0	175	624
07:30	56	227	0	0	283	0	0	0	0	0	0	166	45	0	211	114	0	82	0	196	690
07:45	34	206	0	0	240	0	0	0	0	0	0	147	34	0	181	148	1	122	1	272	693
Total Volume	174	858	0	0	1032	0	0	0	0	0	0	550	168	0	718	470	1	335	1	807	2557
% App. Total	16.9	83.1	0	0		0	0	0	0	0	0	76.6	23.4	0		58.2	0.1	41.5	0.1		
PHF	.777	.897	.000	.000	.912	.000	.000	.000	.000	.000	.000	.828	.840	.000	.851	.794	.250	.686	.250	.742	.922

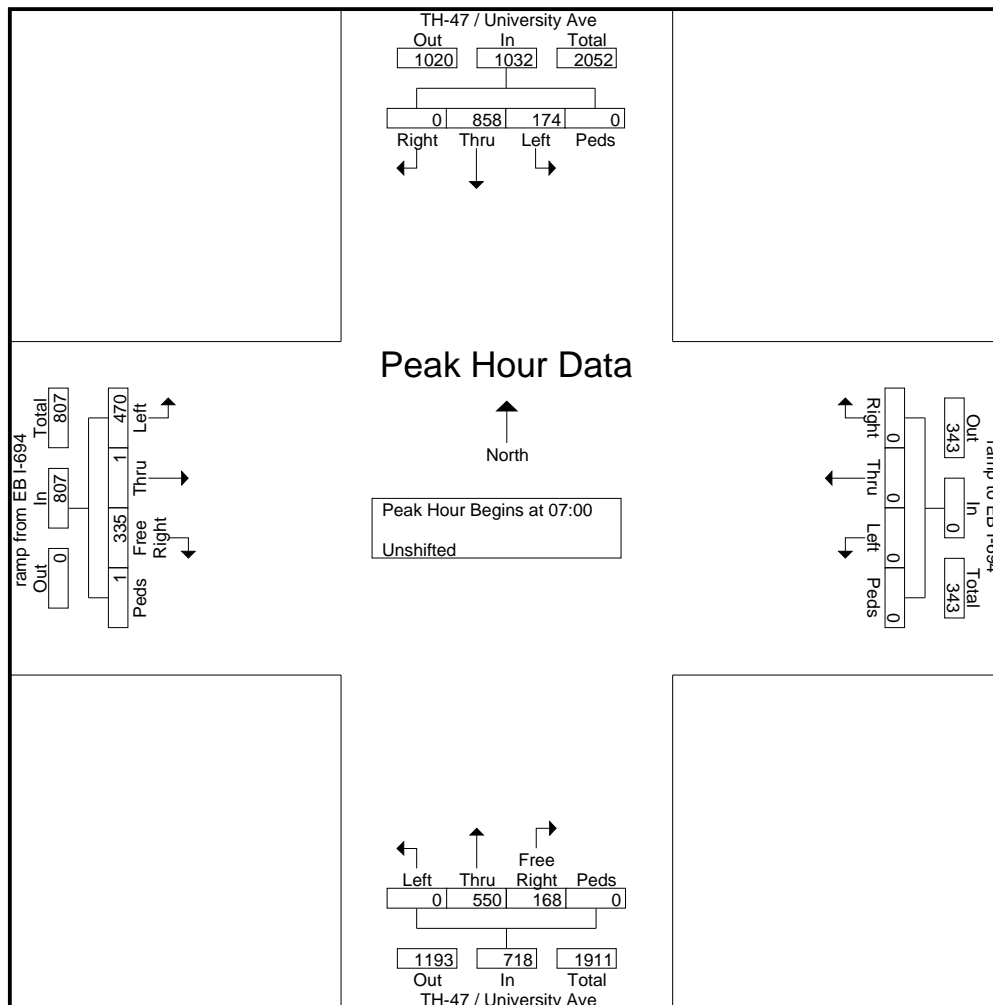

Albeck Gerken, Inc

Transportation Engineers

Traffic Data Collection

TH-47 / University Ave at I-694, S ramps

Ref. Pt.: 007.528

Data by: Albeck Gerken Inc

TURN MOVEMENT COUNT

File Name : TH-47 at I-694 South ramps 2008

Site Code : 01828161

Start Date : 7/10/2008

Page No : 3

Start Time	TH-47 / University Ave Southbound					ramp to EB I-694 Westbound					TH-47 / University Ave Northbound					ramp from EB I-694 Eastbound					Int. Total
	Left	Thru	Right	Peds	App. Total	Left	Thru	Right	Peds	App. Total	Left	Thru	Free Right	Peds	App. Total	Left	Thru	Free Right	Peds	App. Total	
Peak Hour Analysis From 15:00 to 17:45 - Peak 1 of 1																					
Peak Hour for Entire Intersection Begins at 16:30																					
16:30	72	133	0	0	205	0	0	0	1	1	0	314	70	0	384	191	0	116	0	307	897
16:45	47	129	0	0	176	0	0	0	1	1	0	315	51	0	366	178	0	113	1	292	835
17:00	57	131	0	0	188	0	0	0	0	0	0	281	57	0	338	169	1	117	0	287	813
17:15	38	130	0	0	168	0	0	0	0	0	0	311	58	0	369	187	0	113	0	300	837
Total Volume	214	523	0	0	737	0	0	0	2	2	0	1221	236	0	1457	725	1	459	1	1186	3382
% App. Total	29	71	0	0		0	0	0	100		0	83.8	16.2	0		61.1	0.1	38.7	0.1		
PHF	.743	.983	.000	.000	.899	.000	.000	.000	.500	.500	.000	.969	.843	.000	.949	.949	.250	.981	.250	.966	.943

