

# Alliant Engineering

Minneapolis, MN 55415

--TRAFFIC DATA --

I-94 at Boone Ave, South Ramps

Ref.Pt.; 219.520

Alliant Eng.

TURN MOVEMENT COUNT

File Name : 501\_I-94 & Boone Ave S Ramp

Site Code : 501

Start Date : 3/8/2016

Page No : 1

Groups Printed- Vehicles - Trucks

Start Time	Boone Ave Southbound				I-94, South Ramp Westbound				Boone Ave Northbound				I-94, South Ramp Eastbound				Int. Total
	Left	Thru	Rght	Other	Left	Thru	Rght	Other	Left	Thru	Rght	Other	Left	Thru	Rght	Other	
06:00	22	40	2	0	12	3	2	0	0	27	20	0	0	1	0	0	129
06:15	13	57	3	0	13	2	27	0	2	47	25	0	2	3	1	0	195
06:30	16	76	8	0	15	4	44	0	1	41	38	0	3	2	0	0	248
06:45	14	82	6	0	21	6	82	0	0	38	46	2	1	1	0	0	299
Total	65	255	19	0	61	15	155	0	3	153	129	2	6	7	1	0	871
07:00	20	98	4	0	14	9	81	0	3	44	45	0	3	10	2	0	333
07:15	39	108	4	0	21	11	58	0	1	55	31	0	7	4	1	0	340
07:30	35	97	10	0	20	9	62	0	1	66	57	0	3	8	2	0	370
07:45	22	63	13	0	18	7	46	0	2	65	40	0	7	1	2	0	286
Total	116	366	31	0	73	36	247	0	7	230	173	0	20	23	7	0	1329
08:00	23	73	7	0	15	10	57	0	5	41	34	3	8	9	0	0	285
08:15	15	42	8	0	12	11	51	0	5	53	33	1	9	4	1	0	245
08:30	23	41	13	0	8	8	66	0	2	47	34	1	8	9	3	0	263
08:45	21	42	10	1	10	4	27	0	3	56	42	0	2	9	1	0	228
Total	82	198	38	1	45	33	201	0	15	197	143	5	27	31	5	0	1021
09:00	18	26	5	0	7	3	21	0	9	35	33	0	10	8	4	0	179
09:15	19	34	10	0	9	4	28	0	3	82	38	0	9	4	4	0	244
*** BREAK ***																	
Total	37	60	15	0	16	7	49	0	12	117	71	0	19	12	8	0	423
*** BREAK ***																	
10:30	34	42	14	0	7	5	14	0	9	48	21	0	7	5	6	0	212
10:45	35	37	20	0	8	11	13	0	10	51	24	0	6	3	6	0	224
Total	69	79	34	0	15	16	27	0	19	99	45	0	13	8	12	0	436
11:00	30	42	12	0	9	5	17	0	8	36	11	1	16	4	7	0	198
11:15	55	55	15	0	10	6	8	0	7	47	25	0	14	11	7	0	260
11:30	49	69	12	0	6	7	8	0	6	62	29	0	13	8	12	0	281
11:45	45	67	15	0	7	6	12	0	6	78	22	0	9	7	5	0	279
Total	179	233	54	0	32	24	45	0	27	223	87	1	52	30	31	0	1018
12:00	30	46	11	1	11	9	22	0	6	97	35	0	13	9	6	0	296
12:15	25	48	7	1	2	6	18	0	5	75	46	0	13	6	6	0	258
12:30	20	45	12	0	13	7	28	0	10	71	43	0	18	12	4	0	283
12:45	36	63	14	1	6	8	24	0	8	84	34	0	9	9	6	0	302
Total	111	202	44	3	32	30	92	0	29	327	158	0	53	36	22	0	1139
13:00	36	39	12	0	10	11	8	0	4	76	29	1	18	6	5	0	255
13:15	47	52	15	0	10	12	21	0	3	54	19	2	15	6	7	0	263
*** BREAK ***																	
Total	83	91	27	0	20	23	29	0	7	130	48	3	33	12	12	0	518
*** BREAK ***																	
14:30	68	84	10	1	13	15	24	0	1	55	31	0	17	5	3	0	327
14:45	69	73	4	1	12	9	18	0	3	62	34	1	18	12	5	0	321
Total	137	157	14	2	25	24	42	0	4	117	65	1	35	17	8	0	648
15:00	63	64	16	0	17	5	15	0	2	63	33	0	12	10	1	0	301
15:15	67	90	13	1	21	10	12	0	6	78	42	0	9	9	2	0	360
15:30	74	65	10	2	18	7	12	0	3	95	40	0	12	6	3	0	347
15:45	120	78	11	1	31	7	10	0	3	83	44	0	16	8	5	0	417
Total	324	297	50	4	87	29	49	0	14	319	159	0	49	33	11	0	1425
16:00	81	94	17	1	21	9	8	0	4	84	38	0	11	7	6	0	381
16:15	131	86	10	0	25	9	7	0	6	76	55	0	17	6	3	0	431
16:30	92	91	12	0	17	8	4	0	4	81	42	0	17	6	6	0	380

# Alliant Engineering

Minneapolis, MN 55415

--TRAFFIC DATA --

I-94 at Boone Ave, South Ramps

Ref.Pt.; 219.520

Alliant Eng.

TURN MOVEMENT COUNT

File Name : 501\_I-94 & Boone Ave S Ramp

Site Code : 501

Start Date : 3/8/2016

Page No : 2

Groups Printed- Vehicles - Trucks

Start Time	Boone Ave Southbound				I-94, South Ramp Westbound				Boone Ave Northbound				I-94, South Ramp Eastbound				Int. Total
	Left	Thru	Rght	Other	Left	Thru	Rght	Other	Left	Thru	Rght	Other	Left	Thru	Rght	Other	
16:45	124	102	19	1	14	5	6	0	2	78	48	0	16	5	9	0	429
Total	428	373	58	2	77	31	25	0	16	319	183	0	61	24	24	0	1621
17:00	70	103	9	0	9	10	9	0	7	76	45	1	7	12	6	0	364
17:15	55	59	5	0	11	9	10	0	4	90	59	0	13	4	1	0	320
17:30	37	48	4	0	14	3	4	0	3	74	31	0	10	4	3	0	235
17:45	52	58	6	0	17	3	9	0	3	56	31	0	11	2	2	0	250
Total	214	268	24	0	51	25	32	0	17	296	166	1	41	22	12	0	1169
Grand Total	1845	2579	408	12	534	293	993	0	170	2527	1427	13	409	255	153	0	11618
Apprch %	38.1	53.2	8.4	0.2	29.3	16.1	54.6	0	4.1	61.1	34.5	0.3	50.1	31.2	18.7	0	
Total %	15.9	22.2	3.5	0.1	4.6	2.5	8.5	0	1.5	21.8	12.3	0.1	3.5	2.2	1.3	0	
Vehicles	1735	2414	394	10	499	274	901	0	163	2389	1363	9	389	239	151	0	10930
% Vehicles	94	93.6	96.6	83.3	93.4	93.5	90.7	0	95.9	94.5	95.5	69.2	95.1	93.7	98.7	0	94.1
Trucks	110	165	14	2	35	19	92	0	7	138	64	4	20	16	2	0	688
% Trucks	6	6.4	3.4	16.7	6.6	6.5	9.3	0	4.1	5.5	4.5	30.8	4.9	6.3	1.3	0	5.9

# Alliant Engineering

Minneapolis, MN 55415

--TRAFFIC DATA --

I-94 at Boone Ave, South Ramps

Ref.Pt.; 219.520

Alliant Eng.

TURN MOVEMENT COUNT

File Name : 501\_I-94 & Boone Ave S Ramp

Site Code : 501

Start Date : 3/8/2016

Page No : 3

Start Time	Boone Ave Southbound					I-94, South Ramp Westbound					Boone Ave Northbound					I-94, South Ramp Eastbound					Int. Total
	Left	Thru	Right	Other	App. Total	Left	Thru	Right	Other	App. Total	Left	Thru	Right	Other	App. Total	Left	Thru	Right	Other	App. Total	
Peak Hour Analysis From 06:00 to 11:45 - Peak 1 of 1																					
Peak Hour for Entire Intersection Begins at 06:45																					
06:45	14	82	6	0	102	21	6	82	0	109	0	38	46	2	86	1	1	0	0	2	299
07:00	20	98	4	0	122	14	9	81	0	104	3	44	45	0	92	3	10	2	0	15	333
07:15	39	108	4	0	151	21	11	58	0	90	1	55	31	0	87	7	4	1	0	12	340
07:30	35	97	10	0	142	20	9	62	0	91	1	66	57	0	124	3	8	2	0	13	370
Total Volume	108	385	24	0	517	76	35	283	0	394	5	203	179	2	389	14	23	5	0	42	1342
% App. Total	20.9	74.5	4.6	0		19.3	8.9	71.8	0		1.3	52.2	46	0.5		33.3	54.8	11.9	0		
PHF	.692	.891	.600	.000	.856	.905	.795	.863	.000	.904	.417	.769	.785	.250	.784	.500	.575	.625	.000	.700	.907

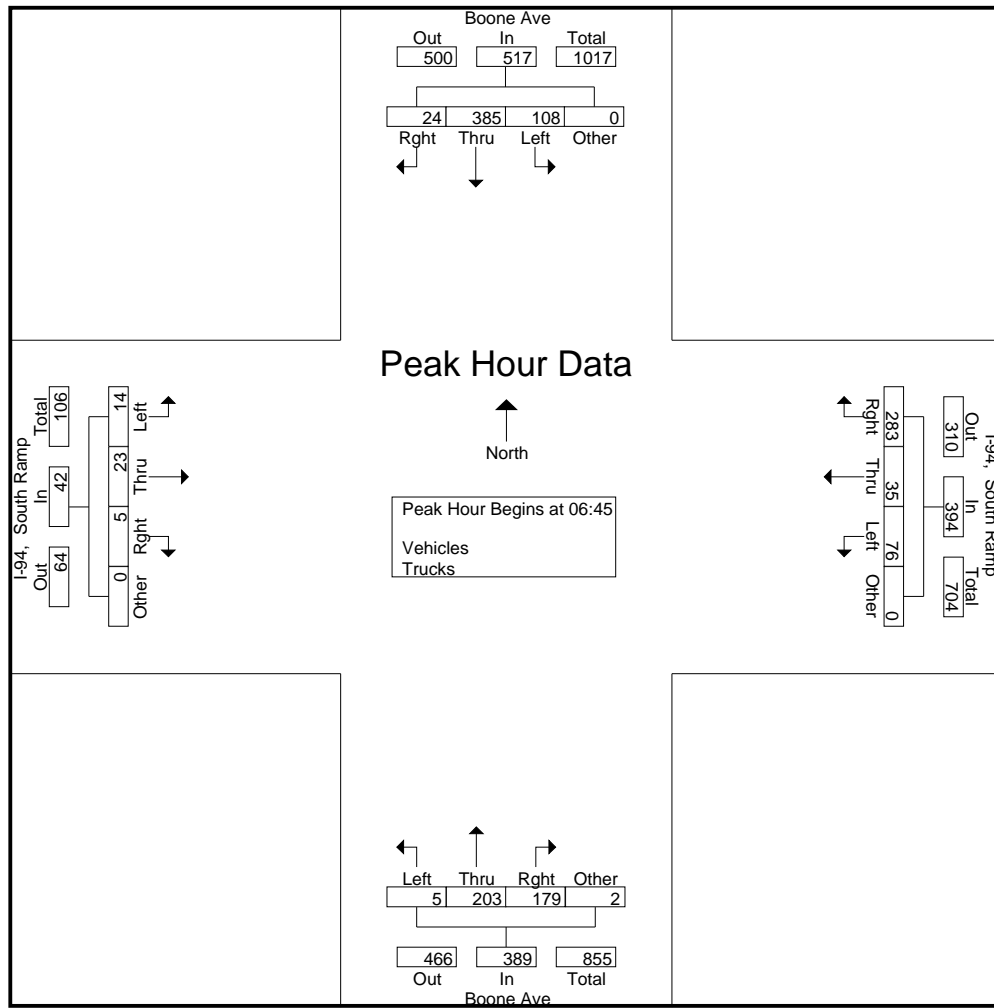

# Alliant Engineering

Minneapolis, MN 55415

--TRAFFIC DATA --

I-94 at Boone Ave, South Ramps

Ref.Pt.; 219.520

Alliant Eng.

TURN MOVEMENT COUNT

File Name : 501\_I-94 & Boone Ave S Ramp

Site Code : 501

Start Date : 3/8/2016

Page No : 4

Start Time	Boone Ave Southbound					I-94, South Ramp Westbound					Boone Ave Northbound					I-94, South Ramp Eastbound					Int. Total
	Left	Thru	Rght	Other	App. Total	Left	Thru	Rght	Other	App. Total	Left	Thru	Rght	Other	App. Total	Left	Thru	Rght	Other	App. Total	
Peak Hour Analysis From 12:00 to 17:45 - Peak 1 of 1																					
Peak Hour for Entire Intersection Begins at 16:00																					
16:00	81	94	17	1	193	21	9	8	0	38	4	84	38	0	126	11	7	6	0	24	381
16:15	131	86	10	0	227	25	9	7	0	41	6	76	55	0	137	17	6	3	0	26	431
16:30	92	91	12	0	195	17	8	4	0	29	4	81	42	0	127	17	6	6	0	29	380
16:45	124	102	19	1	246	14	5	6	0	25	2	78	48	0	128	16	5	9	0	30	429
Total Volume	428	373	58	2	861	77	31	25	0	133	16	319	183	0	518	61	24	24	0	109	1621
% App. Total	49.7	43.3	6.7	0.2		57.9	23.3	18.8	0		3.1	61.6	35.3	0		56	22	22	0		
PHF	.817	.914	.763	.500	.875	.770	.861	.781	.000	.811	.667	.949	.832	.000	.945	.897	.857	.667	.000	.908	.940

