

Albeck Gerken, Inc

Transportation Engineers

Traffic Data Collection

McKnight Rd at Burns Ave/ ramp to I-94 EB

Ref.Pt.: 246.641

File Name : 13 I-94 South Ramp & McKnight Rd

Site Code : 13

Start Date : 1/13/2012

Page No : 1

TURN MOVEMENT COUNT

Groups Printed- Cars - Heavy Vehicles

Start Time	McKnight Rd Southbound				Ramp to I-94 EB / Hudson Place Westbound				McKnight Rd Northbound				Burns Ave Eastbound				Int. Total
	Left	Thru	Right	Peds	Left	Thru	Right	Peds	Left	Thru	Right	Peds	Left	Thru	Right	Peds	
06:00	11	31	8	0	0	0	0	0	1	49	7	0	3	3	1	0	114
06:15	21	45	10	0	0	1	3	0	3	53	8	0	7	2	2	0	155
06:30	16	32	9	0	0	0	5	0	11	108	16	0	9	10	3	0	219
06:45	16	51	24	0	0	2	7	0	7	98	20	0	12	8	3	0	248
Total	64	159	51	0	0	3	15	0	22	308	51	0	31	23	9	0	736
07:00	25	78	31	0	0	0	3	0	10	129	10	0	19	14	1	1	321
07:15	37	59	35	0	0	2	6	0	8	149	16	0	18	12	8	0	350
07:30	42	69	31	0	1	2	6	0	12	137	17	0	17	14	6	0	354
07:45	34	77	16	0	1	2	6	0	13	123	14	0	14	15	7	0	322
Total	138	283	113	0	2	6	21	0	43	538	57	0	68	55	22	1	1347
08:00	37	65	14	0	2	2	1	0	7	142	10	0	15	15	7	0	317
08:15	38	53	16	0	0	0	5	0	14	124	14	0	8	7	6	1	286
08:30	37	62	6	0	1	1	5	0	11	118	15	0	39	15	10	0	320
08:45	34	77	13	0	1	1	7	0	11	88	14	0	16	12	6	1	281
Total	146	257	49	0	4	4	18	0	43	472	53	0	78	49	29	2	1204
09:00	35	46	21	0	0	2	4	0	10	84	13	0	11	6	4	0	236
09:15	25	53	11	0	1	0	1	0	7	79	13	0	4	12	2	0	208
09:30	25	41	10	0	1	0	6	0	9	54	7	0	7	14	7	1	182
09:45	30	51	1	0	0	0	2	0	7	54	10	0	8	16	4	1	184
Total	115	191	43	0	2	2	13	0	33	271	43	0	30	48	17	2	810
10:00	27	41	11	0	1	0	2	0	3	62	7	0	2	9	8	1	174
10:15	48	51	24	0	0	0	2	0	12	58	5	0	7	8	6	2	223
10:30	37	51	14	0	0	0	1	0	14	58	10	0	10	14	6	1	216
10:45	46	63	17	1	0	0	2	0	3	62	11	0	5	14	7	0	231
Total	158	206	66	1	1	0	7	0	32	240	33	0	24	45	27	4	844
11:00	43	61	13	0	1	1	3	1	19	70	3	0	14	15	6	0	250
11:15	53	71	22	1	0	6	2	3	15	70	7	0	13	9	5	0	277
11:30	74	92	29	0	0	0	5	2	17	57	4	0	20	14	10	0	324
11:45	47	83	20	0	1	0	6	0	6	49	5	0	14	17	14	1	263
Total	217	307	84	1	2	7	16	6	57	246	19	0	61	55	35	1	1114
12:00	59	86	22	0	0	1	2	3	6	70	6	0	11	16	5	0	287
12:15	47	75	28	0	0	4	4	1	9	79	7	0	13	19	12	0	298
12:30	56	70	22	0	0	2	2	0	9	83	12	0	15	21	6	0	298
12:45	43	71	19	0	1	1	3	2	7	86	8	0	12	14	13	0	280
Total	205	302	91	0	1	8	11	6	31	318	33	0	51	70	36	0	1163
13:00	46	68	23	0	1	1	10	0	6	72	11	0	14	10	10	0	272
13:15	55	84	18	0	1	0	3	0	8	65	12	0	11	24	5	1	287
13:30	54	69	18	0	1	0	1	0	12	63	3	0	14	24	8	1	268
13:45	46	76	28	0	0	1	0	0	5	64	9	0	9	15	7	0	260
Total	201	297	87	0	3	2	14	0	31	264	35	0	48	73	30	2	1087
14:00	44	73	22	0	0	0	3	0	9	85	10	0	14	20	11	0	291
14:15	51	98	20	0	0	1	3	0	8	59	4	0	17	20	13	0	294
14:30	50	95	22	0	0	0	1	0	6	82	17	0	8	17	12	0	310
14:45	68	105	18	2	1	2	2	0	13	62	11	0	11	17	9	0	321
Total	213	371	82	2	1	3	9	0	36	288	42	0	50	74	45	0	1216
15:00	83	111	14	0	0	3	10	1	9	61	14	1	8	12	9	2	338
15:15	84	104	21	0	2	2	5	1	4	71	8	1	15	15	14	2	349
15:30	86	126	17	0	0	2	0	0	12	87	9	0	14	32	12	1	398
15:45	83	107	22	0	0	2	0	1	3	93	6	0	15	11	10	0	353
Total	336	448	74	0	2	9	15	3	28	312	37	2	52	70	45	5	1438

Albeck Gerken, Inc

Transportation Engineers

Traffic Data Collection

McKnight Rd at Burns Ave/ ramp to I-94 EB

Ref.Pt.: 246.641

File Name : 13 I-94 South Ramp & McKnight Rd

Site Code : 13

Start Date : 1/13/2012

Page No : 2

TURN MOVEMENT COUNT

Groups Printed- Cars - Heavy Vehicles

Start Time	McKnight Rd Southbound				Ramp to I-94 EB / Hudson Place Westbound				McKnight Rd Northbound				Burns Ave Eastbound				Int. Total
	Left	Thru	Right	Peds	Left	Thru	Right	Peds	Left	Thru	Right	Peds	Left	Thru	Right	Peds	
16:00	106	132	30	0	0	0	3	0	11	78	12	0	12	31	8	0	423
16:15	131	155	35	1	0	2	0	0	4	101	14	0	16	14	8	1	482
16:30	150	160	31	0	0	0	0	0	7	98	7	0	14	37	16	2	522
16:45	140	164	21	0	2	0	1	0	13	101	12	0	10	24	23	0	511
Total	527	611	117	1	2	2	4	0	35	378	45	0	52	106	55	3	1938
17:00	144	166	26	0	1	0	9	0	13	88	9	0	5	27	12	1	501
17:15	121	150	30	1	0	0	2	0	11	93	18	0	13	34	16	0	489
17:30	111	134	21	0	2	1	3	0	12	74	14	0	11	26	11	1	421
17:45	88	152	32	0	1	2	1	0	9	99	10	0	11	22	16	1	444
Total	464	602	109	1	4	3	15	0	45	354	51	0	40	109	55	3	1855
18:00	86	106	20	0	0	2	6	0	4	68	12	0	9	24	17	0	354
18:15	75	119	21	1	2	0	2	0	7	78	16	0	7	22	14	0	364
18:30	60	90	12	0	1	2	0	1	14	83	12	0	4	16	17	0	312
18:45	55	80	18	0	0	1	2	0	9	50	7	0	12	23	12	1	270
Total	276	395	71	1	3	5	10	1	34	279	47	0	32	85	60	1	1300
Grand Total	3060	4429	1037	7	27	54	168	16	470	4268	546	2	617	862	465	24	16052
Apprch %	35.9	51.9	12.2	0.1	10.2	20.4	63.4	6	8.9	80.7	10.3	0	31.4	43.8	23.6	1.2	
Total %	19.1	27.6	6.5	0	0.2	0.3	1	0.1	2.9	26.6	3.4	0	3.8	5.4	2.9	0.1	
Cars	2979	4174	989	7	24	50	161	16	451	4067	520	2	590	833	431	21	15315
% Cars	97.4	94.2	95.4	100	88.9	92.6	95.8	100	96	95.3	95.2	100	95.6	96.6	92.7	87.5	95.4
Heavy Vehicles	81	255	48	0	3	4	7	0	19	201	26	0	27	29	34	3	737
% Heavy Vehicles	2.6	5.8	4.6	0	11.1	7.4	4.2	0	4	4.7	4.8	0	4.4	3.4	7.3	12.5	4.6

Albeck Gerken, Inc

Transportation Engineers

Traffic Data Collection

McKnight Rd at Burns Ave/ ramp to I-94 EB

Ref.Pt.: 246.641

File Name : 13 I-94 South Ramp & McKnight Rd

Site Code : 13

Start Date : 1/13/2012

Page No : 3

TURN MOVEMENT COUNT

Start Time	McKnight Rd Southbound					Ramp to I-94 EB / Hudson Place Westbound					McKnight Rd Northbound					Burns Ave Eastbound					Int. Total
	Left	Thru	Right	Peds	App. Total	Left	Thru	Right	Peds	App. Total	Left	Thru	Right	Peds	App. Total	Left	Thru	Right	Peds	App. Total	
Peak Hour Analysis From 06:00 to 09:30 - Peak 1 of 1																					
Peak Hour for Entire Intersection Begins at 07:00																					
07:00	25	78	31	0	134	0	0	3	0	3	10	129	10	0	149	19	14	1	1	35	321
07:15	37	59	35	0	131	0	2	6	0	8	8	149	16	0	173	18	12	8	0	38	350
07:30	42	69	31	0	142	1	2	6	0	9	12	137	17	0	166	17	14	6	0	37	354
07:45	34	77	16	0	127	1	2	6	0	9	13	123	14	0	150	14	15	7	0	36	322
Total Volume	138	283	113	0	534	2	6	21	0	29	43	538	57	0	638	68	55	22	1	146	1347
% App. Total	25.8	53	21.2	0		6.9	20.7	72.4	0		6.7	84.3	8.9	0		46.6	37.7	15.1	0.7		
PHF	.821	.907	.807	.000	.940	.500	.750	.875	.000	.806	.827	.903	.838	.000	.922	.895	.917	.688	.250	.961	.951

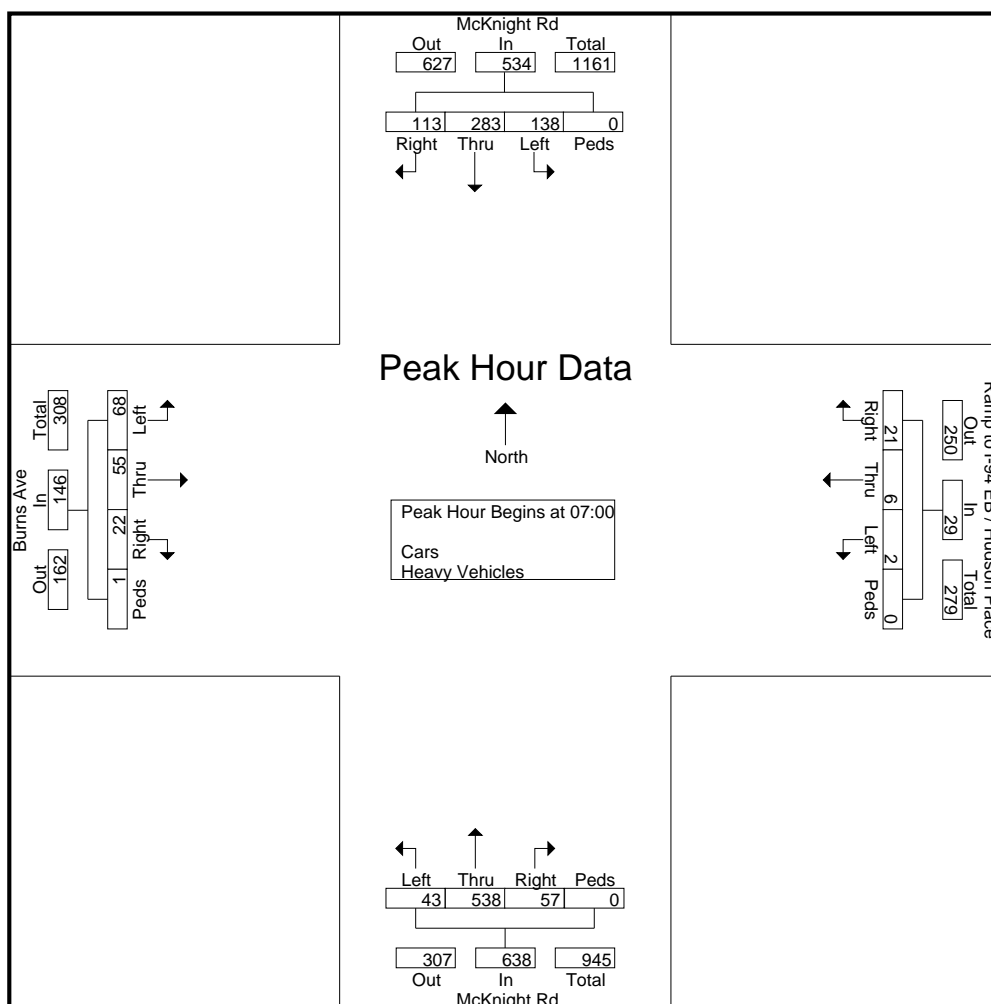

Albeck Gerken, Inc

Transportation Engineers

Traffic Data Collection

McKnight Rd at Burns Ave/ ramp to I-94 EB
Ref.Pt.: 246.641

File Name : 13 I-94 South Ramp & McKnight Rd

Site Code : 13

Start Date : 1/13/2012

Page No : 4

TURN MOVEMENT COUNT

Start Time	McKnight Rd Southbound					Ramp to I-94 EB / Hudson Place Westbound					McKnight Rd Northbound					Burns Ave Eastbound					Int. Total
	Left	Thru	Right	Peds	App. Total	Left	Thru	Right	Peds	App. Total	Left	Thru	Right	Peds	App. Total	Left	Thru	Right	Peds	App. Total	
Peak Hour Analysis From 15:00 to 18:45 - Peak 1 of 1																					
Peak Hour for Entire Intersection Begins at 16:30																					
16:30	150	160	31	0	341	0	0	0	0	0	7	98	7	0	112	14	37	16	2	69	522
16:45	140	164	21	0	325	2	0	1	0	3	13	101	12	0	126	10	24	23	0	57	511
17:00	144	166	26	0	336	1	0	9	0	10	13	88	9	0	110	5	27	12	1	45	501
17:15	121	150	30	1	302	0	0	2	0	2	11	93	18	0	122	13	34	16	0	63	489
Total Volume	555	640	108	1	1304	3	0	12	0	15	44	380	46	0	470	42	122	67	3	234	2023
% App. Total	42.6	49.1	8.3	0.1		20	0	80	0		9.4	80.9	9.8	0		17.9	52.1	28.6	1.3		
PHF	.925	.964	.871	.250	.956	.375	.000	.333	.000	.375	.846	.941	.639	.000	.933	.750	.824	.728	.375	.848	.969

