

# Alliant Engineering

Minneapolis, MN 55415

--TRAFFIC DATA --

Foley Blvd at 99th Ave  
 Ref.Pt.:  
 Alliant Eng.  
 TURN MOVEMENT COUNT

File Name : 321\_Foley Blvd & 99th Ave  
 Site Code : 321  
 Start Date : 3/1/2016  
 Page No : 1

Groups Printed- Vehicles - Trucks

| Start Time    | Foley Blvd Southbound |      |      |       | 99th Ave Westbound |      |      |       | Foley Blvd Northbound |      |      |       | 99th Ave Eastbound |      |      |       | Int. Total |
|---------------|-----------------------|------|------|-------|--------------------|------|------|-------|-----------------------|------|------|-------|--------------------|------|------|-------|------------|
|               | Left                  | Thru | Rght | Other | Left               | Thru | Rght | Other | Left                  | Thru | Rght | Other | Left               | Thru | Rght | Other |            |
| 06:00         | 0                     | 95   | 21   | 0     | 0                  | 0    | 0    | 0     | 3                     | 27   | 0    | 0     | 56                 | 0    | 25   | 0     | 227        |
| 06:15         | 0                     | 117  | 24   | 0     | 0                  | 0    | 0    | 0     | 4                     | 37   | 0    | 0     | 50                 | 0    | 37   | 0     | 269        |
| 06:30         | 0                     | 128  | 36   | 0     | 0                  | 0    | 0    | 0     | 10                    | 39   | 0    | 0     | 59                 | 0    | 36   | 0     | 308        |
| 06:45         | 0                     | 152  | 32   | 0     | 0                  | 0    | 0    | 0     | 15                    | 62   | 0    | 0     | 59                 | 0    | 29   | 0     | 349        |
| Total         | 0                     | 492  | 113  | 0     | 0                  | 0    | 0    | 0     | 32                    | 165  | 0    | 0     | 224                | 0    | 127  | 0     | 1153       |
| 07:00         | 0                     | 143  | 37   | 0     | 0                  | 0    | 0    | 0     | 9                     | 59   | 0    | 0     | 60                 | 0    | 39   | 0     | 347        |
| 07:15         | 0                     | 133  | 55   | 0     | 0                  | 0    | 0    | 0     | 19                    | 65   | 0    | 0     | 72                 | 0    | 34   | 0     | 378        |
| 07:30         | 0                     | 160  | 53   | 0     | 0                  | 0    | 0    | 0     | 14                    | 67   | 0    | 0     | 58                 | 0    | 40   | 0     | 392        |
| 07:45         | 0                     | 167  | 45   | 0     | 0                  | 0    | 0    | 0     | 23                    | 73   | 0    | 0     | 80                 | 0    | 42   | 0     | 430        |
| Total         | 0                     | 603  | 190  | 0     | 0                  | 0    | 0    | 0     | 65                    | 264  | 0    | 0     | 270                | 0    | 155  | 0     | 1547       |
| 08:00         | 0                     | 113  | 60   | 0     | 0                  | 0    | 0    | 0     | 28                    | 60   | 0    | 0     | 47                 | 0    | 31   | 0     | 339        |
| 08:15         | 0                     | 117  | 42   | 0     | 0                  | 0    | 0    | 0     | 16                    | 66   | 0    | 0     | 54                 | 0    | 20   | 0     | 315        |
| 08:30         | 0                     | 106  | 54   | 0     | 0                  | 0    | 0    | 0     | 26                    | 62   | 0    | 0     | 48                 | 0    | 32   | 0     | 328        |
| 08:45         | 0                     | 106  | 68   | 0     | 0                  | 0    | 0    | 0     | 17                    | 41   | 0    | 0     | 43                 | 0    | 31   | 0     | 306        |
| Total         | 0                     | 442  | 224  | 0     | 0                  | 0    | 0    | 0     | 87                    | 229  | 0    | 0     | 192                | 0    | 114  | 0     | 1288       |
| 09:00         | 0                     | 63   | 53   | 0     | 0                  | 0    | 0    | 0     | 26                    | 74   | 0    | 0     | 46                 | 0    | 42   | 0     | 304        |
| 09:15         | 0                     | 80   | 54   | 0     | 0                  | 0    | 0    | 0     | 27                    | 59   | 0    | 0     | 36                 | 0    | 24   | 0     | 280        |
| *** BREAK *** |                       |      |      |       |                    |      |      |       |                       |      |      |       |                    |      |      |       |            |
| Total         | 0                     | 143  | 107  | 0     | 0                  | 0    | 0    | 0     | 53                    | 133  | 0    | 0     | 82                 | 0    | 66   | 0     | 584        |
| *** BREAK *** |                       |      |      |       |                    |      |      |       |                       |      |      |       |                    |      |      |       |            |
| 10:30         | 0                     | 48   | 61   | 0     | 0                  | 0    | 0    | 0     | 30                    | 49   | 0    | 0     | 62                 | 0    | 26   | 0     | 276        |
| 10:45         | 0                     | 44   | 84   | 0     | 0                  | 0    | 0    | 0     | 24                    | 50   | 0    | 0     | 42                 | 0    | 25   | 0     | 269        |
| Total         | 0                     | 92   | 145  | 0     | 0                  | 0    | 0    | 0     | 54                    | 99   | 0    | 0     | 104                | 0    | 51   | 0     | 545        |
| 11:00         | 0                     | 51   | 64   | 0     | 0                  | 0    | 0    | 0     | 30                    | 67   | 0    | 0     | 55                 | 0    | 29   | 0     | 296        |
| 11:15         | 0                     | 55   | 90   | 0     | 0                  | 0    | 0    | 0     | 35                    | 54   | 0    | 0     | 53                 | 0    | 35   | 0     | 322        |
| 11:30         | 0                     | 50   | 80   | 0     | 0                  | 0    | 0    | 0     | 22                    | 66   | 0    | 0     | 81                 | 0    | 23   | 0     | 322        |
| 11:45         | 0                     | 58   | 77   | 0     | 0                  | 0    | 0    | 0     | 38                    | 83   | 0    | 0     | 68                 | 0    | 43   | 0     | 367        |
| Total         | 0                     | 214  | 311  | 0     | 0                  | 0    | 0    | 0     | 125                   | 270  | 0    | 0     | 257                | 0    | 130  | 0     | 1307       |
| 12:00         | 0                     | 61   | 86   | 0     | 0                  | 0    | 0    | 0     | 39                    | 85   | 0    | 0     | 57                 | 0    | 33   | 0     | 361        |
| 12:15         | 0                     | 73   | 75   | 0     | 0                  | 0    | 0    | 0     | 33                    | 71   | 0    | 0     | 57                 | 0    | 30   | 0     | 339        |
| 12:30         | 0                     | 63   | 57   | 0     | 0                  | 0    | 0    | 0     | 35                    | 73   | 0    | 0     | 59                 | 0    | 37   | 0     | 324        |
| 12:45         | 0                     | 61   | 69   | 0     | 0                  | 0    | 0    | 0     | 41                    | 57   | 0    | 0     | 56                 | 0    | 28   | 0     | 312        |
| Total         | 0                     | 258  | 287  | 0     | 0                  | 0    | 0    | 0     | 148                   | 286  | 0    | 0     | 229                | 0    | 128  | 0     | 1336       |
| 13:00         | 0                     | 71   | 64   | 0     | 0                  | 0    | 0    | 0     | 43                    | 76   | 0    | 0     | 57                 | 0    | 23   | 0     | 334        |
| 13:15         | 0                     | 57   | 68   | 0     | 0                  | 0    | 0    | 0     | 26                    | 78   | 0    | 0     | 67                 | 0    | 37   | 0     | 333        |
| *** BREAK *** |                       |      |      |       |                    |      |      |       |                       |      |      |       |                    |      |      |       |            |
| Total         | 0                     | 128  | 132  | 0     | 0                  | 0    | 0    | 0     | 69                    | 154  | 0    | 0     | 124                | 0    | 60   | 0     | 667        |
| *** BREAK *** |                       |      |      |       |                    |      |      |       |                       |      |      |       |                    |      |      |       |            |
| 14:30         | 0                     | 62   | 93   | 0     | 0                  | 0    | 0    | 0     | 40                    | 107  | 0    | 0     | 62                 | 0    | 38   | 0     | 402        |
| 14:45         | 0                     | 75   | 83   | 0     | 0                  | 0    | 0    | 0     | 38                    | 117  | 0    | 0     | 83                 | 0    | 25   | 0     | 421        |
| Total         | 0                     | 137  | 176  | 0     | 0                  | 0    | 0    | 0     | 78                    | 224  | 0    | 0     | 145                | 0    | 63   | 0     | 823        |
| 15:00         | 0                     | 71   | 94   | 0     | 0                  | 0    | 0    | 0     | 41                    | 172  | 0    | 0     | 77                 | 0    | 34   | 0     | 489        |
| 15:15         | 0                     | 98   | 91   | 0     | 0                  | 0    | 0    | 0     | 36                    | 221  | 0    | 0     | 75                 | 0    | 45   | 0     | 566        |
| 15:30         | 0                     | 95   | 89   | 0     | 0                  | 0    | 0    | 0     | 44                    | 242  | 0    | 0     | 75                 | 0    | 25   | 0     | 570        |
| 15:45         | 0                     | 72   | 104  | 0     | 0                  | 0    | 0    | 0     | 57                    | 221  | 0    | 0     | 80                 | 0    | 34   | 0     | 568        |
| Total         | 0                     | 336  | 378  | 0     | 0                  | 0    | 0    | 0     | 178                   | 856  | 0    | 0     | 307                | 0    | 138  | 0     | 2193       |
| 16:00         | 0                     | 76   | 134  | 0     | 0                  | 0    | 0    | 0     | 86                    | 202  | 0    | 0     | 76                 | 0    | 46   | 0     | 620        |
| 16:15         | 0                     | 89   | 133  | 0     | 0                  | 0    | 0    | 0     | 55                    | 216  | 0    | 0     | 66                 | 0    | 18   | 0     | 577        |
| 16:30         | 0                     | 69   | 125  | 0     | 0                  | 0    | 0    | 0     | 58                    | 235  | 0    | 0     | 74                 | 0    | 34   | 0     | 595        |

# Alliant Engineering

Minneapolis, MN 55415

--TRAFFIC DATA --

Foley Blvd at 99th Ave  
 Ref.Pt.:  
 Alliant Eng.  
 TURN MOVEMENT COUNT

File Name : 321\_Foley Blvd & 99th Ave  
 Site Code : 321  
 Start Date : 3/1/2016  
 Page No : 2

Groups Printed- Vehicles - Trucks

| Start Time  | Foley Blvd Southbound |      |      |       | 99th Ave Westbound |      |      |       | Foley Blvd Northbound |      |      |       | 99th Ave Eastbound |      |      |       | Int. Total |
|-------------|-----------------------|------|------|-------|--------------------|------|------|-------|-----------------------|------|------|-------|--------------------|------|------|-------|------------|
|             | Left                  | Thru | Rght | Other | Left               | Thru | Rght | Other | Left                  | Thru | Rght | Other | Left               | Thru | Rght | Other |            |
| 16:45       | 0                     | 97   | 115  | 0     | 0                  | 0    | 0    | 0     | 75                    | 176  | 0    | 0     | 86                 | 0    | 41   | 0     | 590        |
| Total       | 0                     | 331  | 507  | 0     | 0                  | 0    | 0    | 0     | 274                   | 829  | 0    | 0     | 302                | 0    | 139  | 0     | 2382       |
| 17:00       | 0                     | 58   | 121  | 0     | 0                  | 0    | 0    | 0     | 68                    | 215  | 0    | 0     | 81                 | 0    | 34   | 0     | 577        |
| 17:15       | 0                     | 90   | 126  | 0     | 0                  | 0    | 0    | 0     | 59                    | 171  | 0    | 0     | 83                 | 0    | 31   | 0     | 560        |
| 17:30       | 0                     | 63   | 88   | 0     | 0                  | 0    | 0    | 0     | 51                    | 214  | 0    | 0     | 68                 | 0    | 33   | 0     | 517        |
| 17:45       | 0                     | 78   | 89   | 0     | 0                  | 0    | 0    | 0     | 45                    | 168  | 0    | 0     | 70                 | 0    | 32   | 0     | 482        |
| Total       | 0                     | 289  | 424  | 0     | 0                  | 0    | 0    | 0     | 223                   | 768  | 0    | 0     | 302                | 0    | 130  | 0     | 2136       |
| Grand Total | 0                     | 3465 | 2994 | 0     | 0                  | 0    | 0    | 0     | 1386                  | 4277 | 0    | 0     | 2538               | 0    | 1301 | 0     | 15961      |
| Apprch %    | 0                     | 53.6 | 46.4 | 0     | 0                  | 0    | 0    | 0     | 24.5                  | 75.5 | 0    | 0     | 66.1               | 0    | 33.9 | 0     |            |
| Total %     | 0                     | 21.7 | 18.8 | 0     | 0                  | 0    | 0    | 0     | 8.7                   | 26.8 | 0    | 0     | 15.9               | 0    | 8.2  | 0     |            |
| Vehicles    | 0                     | 3373 | 2926 | 0     | 0                  | 0    | 0    | 0     | 1343                  | 4131 | 0    | 0     | 2482               | 0    | 1258 | 0     | 15513      |
| % Vehicles  | 0                     | 97.3 | 97.7 | 0     | 0                  | 0    | 0    | 0     | 96.9                  | 96.6 | 0    | 0     | 97.8               | 0    | 96.7 | 0     | 97.2       |
| Trucks      | 0                     | 92   | 68   | 0     | 0                  | 0    | 0    | 0     | 43                    | 146  | 0    | 0     | 56                 | 0    | 43   | 0     | 448        |
| % Trucks    | 0                     | 2.7  | 2.3  | 0     | 0                  | 0    | 0    | 0     | 3.1                   | 3.4  | 0    | 0     | 2.2                | 0    | 3.3  | 0     | 2.8        |

# Alliant Engineering

Minneapolis, MN 55415

--TRAFFIC DATA --

Foley Blvd at 99th Ave  
 Ref.Pt.:  
 Alliant Eng.  
 TURN MOVEMENT COUNT

File Name : 321\_Foley Blvd & 99th Ave  
 Site Code : 321  
 Start Date : 3/1/2016  
 Page No : 3

| Start Time   | Foley Blvd Southbound |      |       |       |            | 99th Ave Westbound |      |       |       |            | Foley Blvd Northbound |      |       |       |            | 99th Ave Eastbound |      |       |       |            | Int. Total |
|--|-----------------------|------|-------|-------|------------|--------------------|------|-------|-------|------------|-----------------------|------|-------|-------|------------|--------------------|------|-------|-------|------------|------------|
|  | Left                  | Thru | Right | Other | App. Total | Left               | Thru | Right | Other | App. Total | Left                  | Thru | Right | Other | App. Total | Left               | Thru | Right | Other | App. Total |            |
| Peak Hour Analysis From 06:00 to 11:45 - Peak 1 of 1 |                       |      |       |       |            |                    |      |       |       |            |                       |      |       |       |            |                    |      |       |       |            |            |
| Peak Hour for Entire Intersection Begins at 07:00    |                       |      |       |       |            |                    |      |       |       |            |                       |      |       |       |            |                    |      |       |       |            |            |
| 07:00  | 0                     | 143  | 37    | 0     | 180        | 0                  | 0    | 0     | 0     | 0          | 9                     | 59   | 0     | 0     | 68         | 60                 | 0    | 39    | 0     | 99         | 347        |
| 07:15  | 0                     | 133  | 55    | 0     | 188        | 0                  | 0    | 0     | 0     | 0          | 19                    | 65   | 0     | 0     | 84         | 72                 | 0    | 34    | 0     | 106        | 378        |
| 07:30  | 0                     | 160  | 53    | 0     | 213        | 0                  | 0    | 0     | 0     | 0          | 14                    | 67   | 0     | 0     | 81         | 58                 | 0    | 40    | 0     | 98         | 392        |
| 07:45  | 0                     | 167  | 45    | 0     | 212        | 0                  | 0    | 0     | 0     | 0          | 23                    | 73   | 0     | 0     | 96         | 80                 | 0    | 42    | 0     | 122        | 430        |
| Total Volume   | 0                     | 603  | 190   | 0     | 793        | 0                  | 0    | 0     | 0     | 0          | 65                    | 264  | 0     | 0     | 329        | 270                | 0    | 155   | 0     | 425        | 1547       |
| % App. Total   | 0                     | .76  | .24   | 0     |            | 0                  | 0    | 0     | 0     | 0          | 19.8                  | 80.2 | 0     | 0     |            | 63.5               | 0    | 36.5  | 0     |            |            |
| PHF  | .000                  | .903 | .864  | .000  | .931       | .000               | .000 | .000  | .000  | .000       | .707                  | .904 | .000  | .000  | .857       | .844               | .000 | .923  | .000  | .871       | .899       |

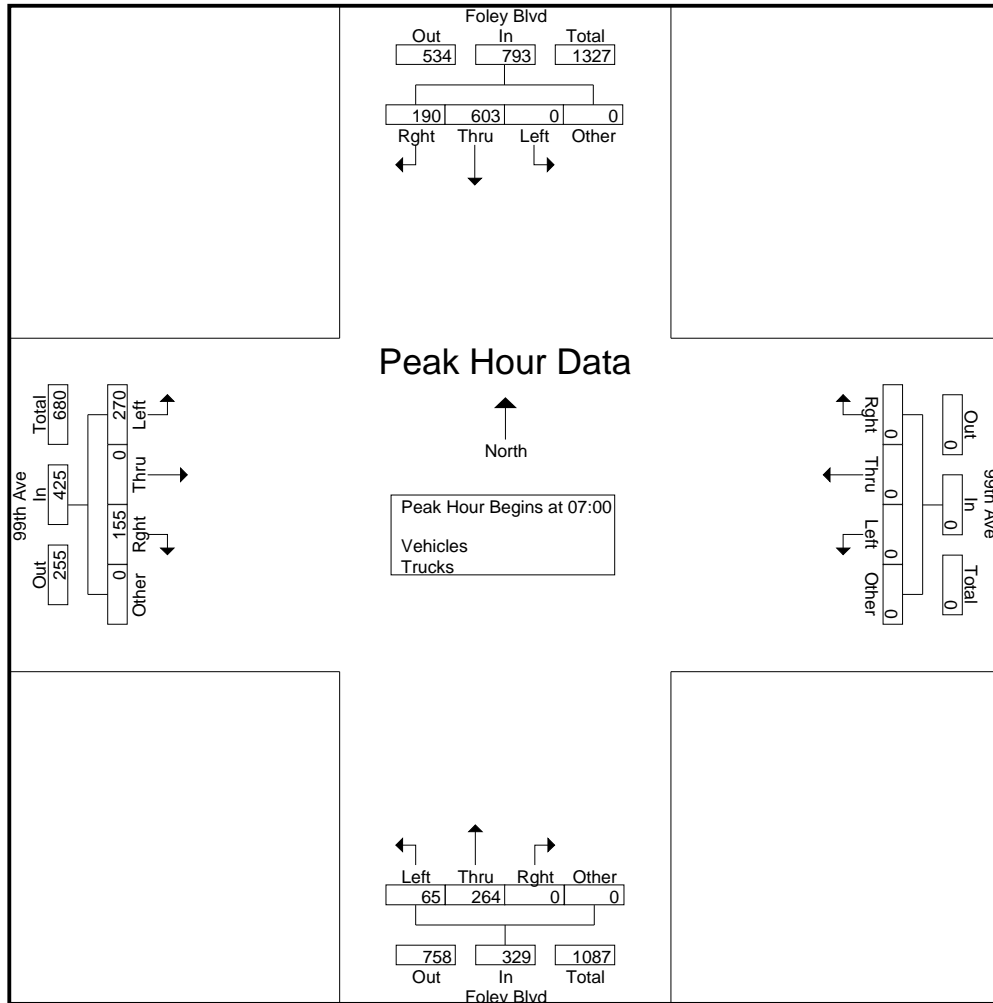

# Alliant Engineering

Minneapolis, MN 55415

--TRAFFIC DATA --

Foley Blvd at 99th Ave  
 Ref.Pt.:  
 Alliant Eng.  
 TURN MOVEMENT COUNT

File Name : 321\_Foley Blvd & 99th Ave  
 Site Code : 321  
 Start Date : 3/1/2016  
 Page No : 4

| Start Time   | Foley Blvd Southbound |      |      |       |            | 99th Ave Westbound |      |      |       |            | Foley Blvd Northbound |      |      |       |            | 99th Ave Eastbound |      |      |       |            | Int. Total |
|--|-----------------------|------|------|-------|------------|--------------------|------|------|-------|------------|-----------------------|------|------|-------|------------|--------------------|------|------|-------|------------|------------|
|  | Left                  | Thru | Rght | Other | App. Total | Left               | Thru | Rght | Other | App. Total | Left                  | Thru | Rght | Other | App. Total | Left               | Thru | Rght | Other | App. Total |            |
| Peak Hour Analysis From 12:00 to 17:45 - Peak 1 of 1 |                       |      |      |       |            |                    |      |      |       |            |                       |      |      |       |            |                    |      |      |       |            |            |
| Peak Hour for Entire Intersection Begins at 16:00    |                       |      |      |       |            |                    |      |      |       |            |                       |      |      |       |            |                    |      |      |       |            |            |
| 16:00  | 0                     | 76   | 134  | 0     | 210        | 0                  | 0    | 0    | 0     | 0          | 86                    | 202  | 0    | 0     | 288        | 76                 | 0    | 46   | 0     | 122        | 620        |
| 16:15  | 0                     | 89   | 133  | 0     | 222        | 0                  | 0    | 0    | 0     | 0          | 55                    | 216  | 0    | 0     | 271        | 66                 | 0    | 18   | 0     | 84         | 577        |
| 16:30  | 0                     | 69   | 125  | 0     | 194        | 0                  | 0    | 0    | 0     | 0          | 58                    | 235  | 0    | 0     | 293        | 74                 | 0    | 34   | 0     | 108        | 595        |
| 16:45  | 0                     | 97   | 115  | 0     | 212        | 0                  | 0    | 0    | 0     | 0          | 75                    | 176  | 0    | 0     | 251        | 86                 | 0    | 41   | 0     | 127        | 590        |
| Total Volume   | 0                     | 331  | 507  | 0     | 838        | 0                  | 0    | 0    | 0     | 0          | 274                   | 829  | 0    | 0     | 1103       | 302                | 0    | 139  | 0     | 441        | 2382       |
| % App. Total   | 0                     | 39.5 | 60.5 | 0     |            | 0                  | 0    | 0    | 0     |            | 24.8                  | 75.2 | 0    | 0     |            | 68.5               | 0    | 31.5 | 0     |            |            |
| PHF  | .000                  | .853 | .946 | .000  | .944       | .000               | .000 | .000 | .000  | .000       | .797                  | .882 | .000 | .000  | .941       | .878               | .000 | .755 | .000  | .868       | .960       |

