



MINNESOTA DEPT OF TRANSPORTATION

TRAFFIC DATA COLLECTION - METRO

TH-100 AT 57TH AVE N., WEST RAMPS
 REF.PT.: 014.894
 JAMAR # D4-3358 KF
 TURN MOVEMENT COUNT

File Name : TH-100 at 57th Ave N west ramp 2007
 Site Code : 00000000
 Start Date : 5/10/2007
 Page No : 1

TH-100 AT 57TH AVE N./ BASS LAKE RD., WEST RAMPS

Groups Printed- Cars & Trucks

Start Time	RAMP FROM TH-100 SB / FRT RD. Southbound				57TH AVE N./ BASS LAKE RD. Westbound				RAMP TO TH-100 SB Northbound				57TH AVE N./ BASS LAKE RD. Eastbound				Int. Total
	Left	Thru	Right	Peds	Left	Thru	Right	Peds	Left	Thru	Right	Peds	Left	Thru	Right	Peds	
06:00	8	0	6	0	37	14	0	0	0	0	0	0	0	21	7	0	93
06:15	16	1	19	0	39	26	0	0	0	0	0	0	0	32	2	0	135
06:30	17	2	25	0	49	36	0	0	0	0	0	0	0	60	3	0	192
06:45	18	1	31	0	40	32	0	0	0	0	0	0	0	44	6	0	172
Total	59	4	81	0	165	108	0	0	0	0	0	0	0	157	18	0	592
07:00	28	1	25	0	58	31	0	0	0	0	0	0	0	54	8	0	205
07:15	23	10	70	0	59	55	0	0	0	0	0	0	0	69	12	0	298
07:30	27	25	100	0	45	68	0	0	0	0	0	0	0	87	7	0	359
07:45	28	39	140	0	43	83	3	0	0	0	0	0	0	85	10	0	431
Total	106	75	335	0	205	237	3	0	0	0	0	0	0	295	37	0	1293
08:00	33	34	99	0	34	63	0	0	0	0	0	0	0	74	6	0	343
08:15	46	16	87	0	43	76	0	0	0	0	0	0	0	61	5	0	334
08:30	19	7	40	0	56	70	0	0	0	0	0	0	0	59	9	0	260
08:45	23	9	61	0	30	55	0	0	0	0	0	0	0	64	12	0	254
Total	121	66	287	0	163	264	0	0	0	0	0	0	0	258	32	0	1191
*** BREAK ***																	
15:00	47	13	51	0	40	94	0	0	0	0	0	0	0	131	22	0	398
15:15	53	17	58	0	29	83	0	0	0	0	0	0	0	123	20	0	383
15:30	65	9	67	0	31	74	0	0	0	0	0	0	0	107	15	0	368
15:45	43	10	59	0	34	81	0	0	0	0	0	0	0	141	18	0	386
Total	208	49	235	0	134	332	0	0	0	0	0	0	0	502	75	0	1535
16:00	53	25	65	0	32	94	0	0	0	0	0	0	0	158	20	0	447
16:15	46	26	62	0	35	82	0	0	0	0	0	0	0	137	20	0	408
16:30	56	20	60	0	35	93	0	0	0	0	0	0	0	177	22	0	463
16:45	59	20	53	0	22	84	0	0	0	0	0	0	1	141	10	0	390
Total	214	91	240	0	124	353	0	0	0	0	0	0	1	613	72	0	1708
17:00	62	16	55	0	21	135	0	0	0	0	0	0	0	160	26	0	475
17:15	58	13	81	0	20	117	0	0	0	0	0	0	0	155	15	0	459
17:30	59	8	52	0	31	182	0	0	0	0	0	0	0	178	21	0	531
17:45	48	12	49	0	27	133	0	0	0	0	0	0	0	134	12	0	415
Total	227	49	237	0	99	567	0	0	0	0	0	0	0	627	74	0	1880
Grand Total	935	334	1415	0	890	1861	3	0	0	0	0	0	1	2452	308	0	8199
Apprch %	34.8	12.4	52.7	0	32.3	67.6	0.1	0	0	0	0	0	0	88.8	11.2	0	
Total %	11.4	4.1	17.3	0	10.9	22.7	0	0	0	0	0	0	0	29.9	3.8	0	



MINNESOTA DEPT OF TRANSPORTATION

TRAFFIC DATA COLLECTION - METRO

TH-100 AT 57TH AVE N., WEST RAMPS
 REF.PT.: 014.894
 JAMAR # D4-3358 KF
 TURN MOVEMENT COUNT

File Name : TH-100 at 57th Ave N west ramp 2007
 Site Code : 00000000
 Start Date : 5/10/2007
 Page No : 2

Start Time	RAMP FROM TH-100 SB / FRT RD. Southbound					57TH AVE N./ BASS LAKE RD. Westbound					RAMP TO TH-100 SB Northbound					57TH AVE N./ BASS LAKE RD. Eastbound					Int. Total
	Left	Thru	Right	Peds	App. Total	Left	Thru	Right	Peds	App. Total	Left	Thru	Right	Peds	App. Total	Left	Thru	Right	Peds	App. Total	
Peak Hour Analysis From 06:00 to 08:45 - Peak 1 of 1																					
Peak Hour for Entire Intersection Begins at 07:30																					
07:30	27	25	100	0	152	45	68	0	0	113	0	0	0	0	0	0	87	7	0	94	359
07:45	28	39	140	0	207	43	83	3	0	129	0	0	0	0	0	0	85	10	0	95	431
08:00	33	34	99	0	166	34	63	0	0	97	0	0	0	0	0	0	74	6	0	80	343
08:15	46	16	87	0	149	43	76	0	0	119	0	0	0	0	0	0	61	5	0	66	334
Total Volume	134	114	426	0	674	165	290	3	0	458	0	0	0	0	0	0	307	28	0	335	1467
% App. Total																					
PHF	.728	.731	.761	.000	.814	.917	.873	.250	.000	.888	.000	.000	.000	.000	.000	.000	.882	.700	.000	.882	.851

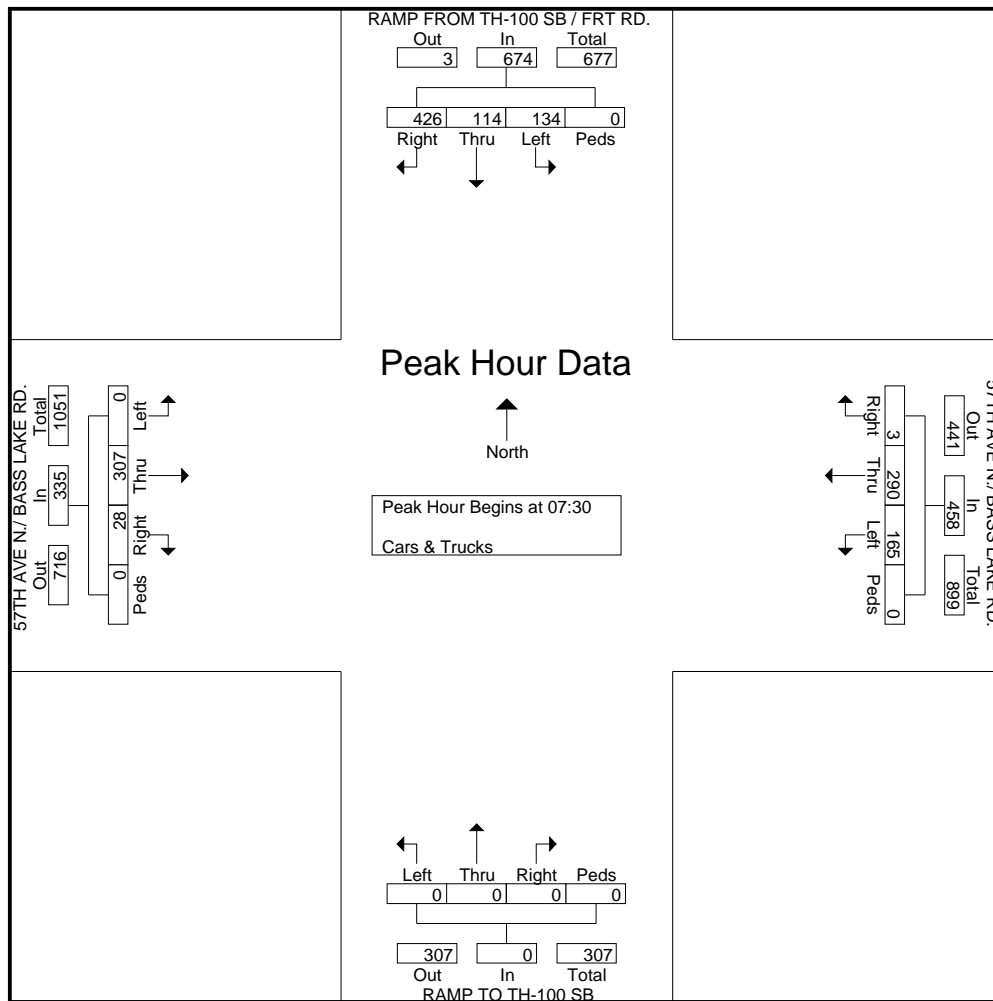



MINNESOTA DEPT OF TRANSPORTATION

TRAFFIC DATA COLLECTION - METRO

TH-100 AT 57TH AVE N., WEST RAMPS
 REF.PT.: 014.894
 JAMAR # D4-3358 KF
 TURN MOVEMENT COUNT

File Name : TH-100 at 57th Ave N west ramp 2007
 Site Code : 00000000
 Start Date : 5/10/2007
 Page No : 3

Start Time	RAMP FROM TH-100 SB / FRT RD. Southbound					57TH AVE N./ BASS LAKE RD. Westbound					RAMP TO TH-100 SB Northbound					57TH AVE N./ BASS LAKE RD. Eastbound					Int. Total
	Left	Thru	Right	Peds	App. Total	Left	Thru	Right	Peds	App. Total	Left	Thru	Right	Peds	App. Total	Left	Thru	Right	Peds	App. Total	
Peak Hour Analysis From 15:00 to 17:45 - Peak 1 of 1																					
Peak Hour for Entire Intersection Begins at 17:00																					
17:00	62	16	55	0	133	21	135	0	0	156	0	0	0	0	0	0	160	26	0	186	475
17:15	58	13	81	0	152	20	117	0	0	137	0	0	0	0	0	0	155	15	0	170	459
17:30	59	8	52	0	119	31	182	0	0	213	0	0	0	0	0	0	178	21	0	199	531
17:45	48	12	49	0	109	27	133	0	0	160	0	0	0	0	0	0	134	12	0	146	415
Total Volume	227	49	237	0	513	99	567	0	0	666	0	0	0	0	0	0	627	74	0	701	1880
% App. Total																					
PHF	.915	.766	.731	.000	.844	.798	.779	.000	.000	.782	.000	.000	.000	.000	.000	.000	.881	.712	.000	.881	.885

