

# Alliant Engineering

Minneapolis, MN 55415

--TRAFFIC DATA --

TH-149 at Argenta Trail

File Name : 117 - TH 149 & Argenta Trail

Site Code : 117

BY: Alliant Eng.

Start Date : 12/3/2014

TURN MOVEMENT COUNT

Page No : 1

Groups Printed- Cars - Trucks

Start Time	TH 149 Southbound				Argenta Trail Westbound				TH 149 Northbound				Wescott Rd Eastbound				Int. Total
	Left	Thru	Rght	Bikes	Left	Thru	Rght	Bikes	Left	Thru	Rght	Bikes	Left	Thru	Rght	Bikes	
06:00	0	9	4	0	2	14	1	0	9	69	1	0	17	8	3	0	137
06:15	0	17	7	0	1	18	0	0	21	90	0	0	25	8	2	0	189
06:30	0	25	2	0	5	10	1	0	15	100	3	0	23	12	7	0	203
06:45	0	23	9	0	4	12	2	0	24	143	3	0	34	9	10	0	273
Total	0	74	22	0	12	54	4	0	69	402	7	0	99	37	22	0	802
07:00	0	17	17	0	9	29	4	0	12	164	5	0	36	23	8	0	324
07:15	0	26	8	0	8	9	3	0	16	192	5	0	49	13	11	0	340
07:30	0	22	11	0	4	13	4	0	18	209	5	0	51	26	12	0	375
07:45	1	19	12	0	7	12	1	0	28	225	7	0	63	19	5	0	399
Total	1	84	48	0	28	63	12	0	74	790	22	0	199	81	36	0	1438
08:00	1	24	20	0	3	6	2	0	21	157	11	0	48	29	5	0	327
08:15	1	35	22	0	4	10	0	0	27	143	8	0	41	24	3	0	318
08:30	0	18	17	0	1	9	0	0	8	119	6	0	28	16	8	0	230
08:45	1	22	8	0	5	17	1	0	13	83	2	0	13	10	5	0	180
Total	3	99	67	0	13	42	3	0	69	502	27	0	130	79	21	0	1055
09:00	0	29	7	0	6	14	4	0	13	62	3	0	14	9	5	0	166
09:15	0	35	13	0	11	10	1	0	11	76	11	0	25	20	9	0	222
*** BREAK ***																	
Total	0	64	20	0	17	24	5	0	24	138	14	0	39	29	14	0	388
*** BREAK ***																	
10:30	2	27	4	0	8	5	2	0	1	51	2	0	10	8	3	0	123
10:45	1	25	9	0	6	6	0	0	2	37	4	0	8	4	5	0	107
Total	3	52	13	0	14	11	2	0	3	88	6	0	18	12	8	0	230
11:00	0	26	9	0	1	3	2	0	3	34	3	0	17	8	4	0	110
11:15	2	52	9	0	8	3	0	0	3	37	3	0	7	4	2	0	130
11:30	2	40	15	0	6	9	1	0	4	43	5	0	10	2	5	0	142
11:45	1	34	15	0	1	12	1	0	7	35	3	0	14	7	7	0	137
Total	5	152	48	0	16	27	4	0	17	149	14	0	48	21	18	0	519
12:00	1	34	14	0	9	11	2	0	4	35	1	0	11	5	5	0	132
12:15	1	48	12	0	1	7	0	0	7	33	4	0	11	3	4	0	131
12:30	1	33	7	0	4	3	0	0	2	49	3	0	11	6	6	0	125
12:45	3	34	10	0	5	1	0	0	4	40	3	0	6	4	8	0	118
Total	6	149	43	0	19	22	2	0	17	157	11	0	39	18	23	0	506
13:00	0	37	11	0	2	10	2	0	7	45	0	0	15	8	4	0	141
13:15	0	23	12	1	4	4	0	0	6	41	5	1	12	7	3	0	119
*** BREAK ***																	
Total	0	60	23	1	6	14	2	0	13	86	5	1	27	15	7	0	260
*** BREAK ***																	
14:30	1	69	17	0	4	14	4	0	11	39	5	0	12	30	33	0	239
14:45	1	67	18	0	3	9	1	0	3	43	6	0	25	10	9	0	195
Total	2	136	35	0	7	23	5	0	14	82	11	0	37	40	42	0	434
15:00	0	92	14	0	7	10	4	0	5	40	0	0	13	12	14	0	211
15:15	0	81	25	0	4	17	0	0	8	42	5	0	15	11	19	0	227
15:30	0	101	24	0	5	14	2	0	8	46	6	0	20	20	13	0	259
15:45	1	136	35	0	3	7	3	0	5	73	10	0	18	14	16	0	321
Total	1	410	98	0	19	48	9	0	26	201	21	0	66	57	62	0	1018
16:00	1	103	31	0	7	13	2	0	4	34	4	0	10	13	18	0	240
16:15	2	135	37	0	8	13	0	0	8	38	8	0	16	18	32	0	315
16:30	1	155	41	0	4	5	2	0	7	52	7	0	11	15	25	0	325

# Alliant Engineering

Minneapolis, MN 55415

--TRAFFIC DATA --

TH-149 at Argenta Trail

File Name : 117 - TH 149 & Argenta Trail

Site Code : 117

BY: Alliant Eng.

Start Date : 12/3/2014

TURN MOVEMENT COUNT

Page No : 2

Groups Printed- Cars - Trucks

Start Time	TH 149 Southbound				Argenta Trail Westbound				TH 149 Northbound				Wescott Rd Eastbound				Int. Total
	Left	Thru	Rght	Bikes	Left	Thru	Rght	Bikes	Left	Thru	Rght	Bikes	Left	Thru	Rght	Bikes	
16:45	4	146	56	0	13	23	0	1	11	46	7	0	27	21	20	0	375
Total	8	539	165	0	32	54	4	1	30	170	26	0	64	67	95	0	1255
17:00	1	157	54	0	8	14	1	0	7	67	6	0	19	12	16	0	362
17:15	1	145	52	0	10	8	1	0	13	48	1	0	26	17	30	0	352
17:30	0	133	54	0	6	14	1	0	11	39	3	0	19	12	21	0	313
17:45	1	101	33	0	6	13	2	0	3	61	6	0	18	18	17	0	279
Total	3	536	193	0	30	49	5	0	34	215	16	0	82	59	84	0	1306
Grand Total	32	2355	775	1	213	431	57	1	390	2980	180	1	848	515	432	0	9211
Apprch %	1	74.5	24.5	0	30.3	61.4	8.1	0.1	11	83.9	5.1	0	47.2	28.7	24.1	0	
Total %	0.3	25.6	8.4	0	2.3	4.7	0.6	0	4.2	32.4	2	0	9.2	5.6	4.7	0	
Cars	30	2286	739	1	187	426	37	1	385	2898	164	1	819	511	430	0	8915
% Cars	93.8	97.1	95.4	100	87.8	98.8	64.9	100	98.7	97.2	91.1	100	96.6	99.2	99.5	0	96.8
Trucks	2	69	36	0	26	5	20	0	5	82	16	0	29	4	2	0	296
% Trucks	6.2	2.9	4.6	0	12.2	1.2	35.1	0	1.3	2.8	8.9	0	3.4	0.8	0.5	0	3.2

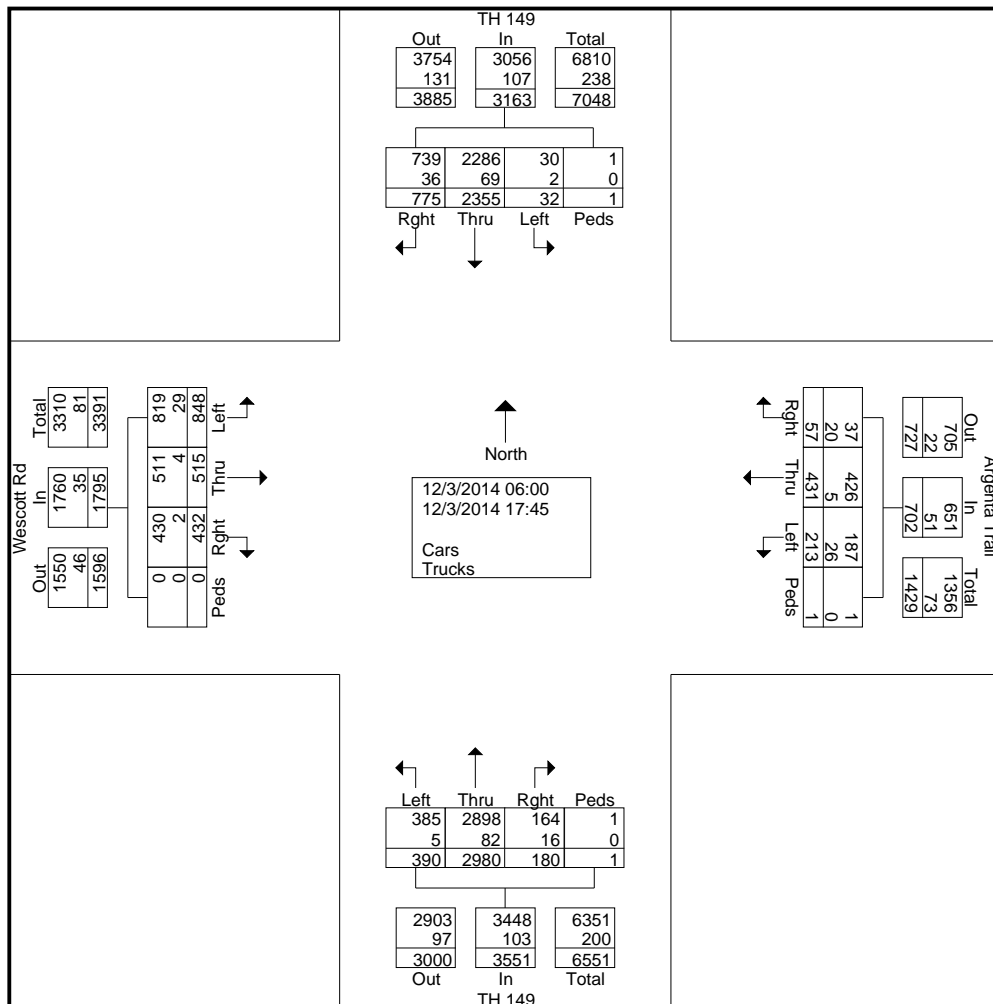

# Alliant Engineering

Minneapolis, MN 55415

--TRAFFIC DATA --

TH-149 at Argenta Trail

File Name : 117 - TH 149 & Argenta Trail

Site Code : 117

BY: Alliant Eng.

Start Date : 12/3/2014

TURN MOVEMENT COUNT

Page No : 3

Start Time	TH 149 Southbound					Argenta Trail Westbound					TH 149 Northbound					Wescott Rd Eastbound					Int. Total
	Left	Thru	Rght	Bikes	App. Total	Left	Thru	Rght	Bikes	App. Total	Left	Thru	Rght	Bikes	App. Total	Left	Thru	Rght	Bikes	App. Total	
Peak Hour Analysis From 06:00 to 11:45 - Peak 1 of 1																					
Peak Hour for Entire Intersection Begins at 07:15																					
07:15	0	26	8	0	34	8	9	3	0	20	16	192	5	0	213	49	13	11	0	73	340
07:30	0	22	11	0	33	4	13	4	0	21	18	209	5	0	232	51	26	12	0	89	375
07:45	1	19	12	0	32	7	12	1	0	20	28	225	7	0	260	63	19	5	0	87	399
08:00	1	24	20	0	45	3	6	2	0	11	21	157	11	0	189	48	29	5	0	82	327
Total Volume	2	91	51	0	144	22	40	10	0	72	83	783	28	0	894	211	87	33	0	331	1441
% App. Total	1.4	63.2	35.4	0		30.6	55.6	13.9	0		9.3	87.6	3.1	0		63.7	26.3	10	0		
PHF	.500	.875	.638	.000	.800	.688	.769	.625	.000	.857	.741	.870	.636	.000	.860	.837	.750	.688	.000	.930	.903

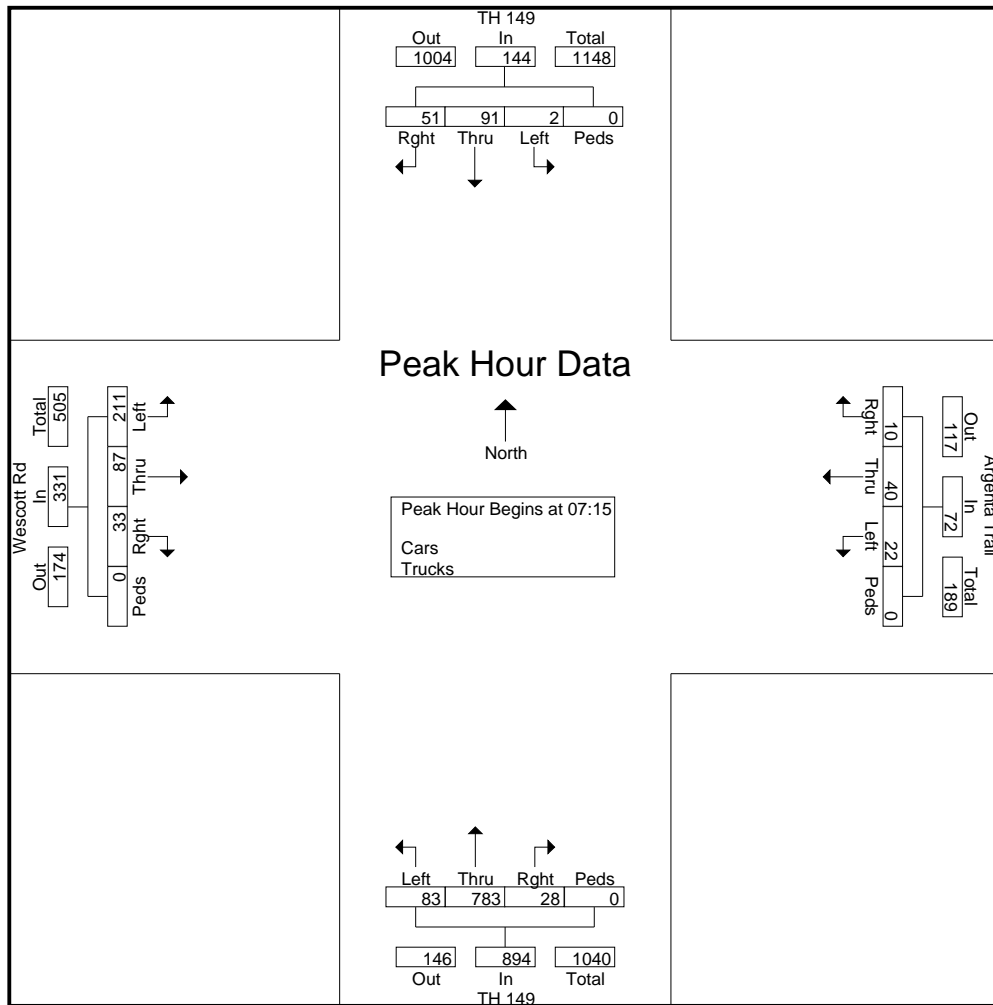

# Alliant Engineering

Minneapolis, MN 55415

--TRAFFIC DATA --

TH-149 at Argenta Trail

File Name : 117 - TH 149 & Argenta Trail

Site Code : 117

BY: Alliant Eng.

Start Date : 12/3/2014

TURN MOVEMENT COUNT

Page No : 4

Start Time	TH 149 Southbound					Argenta Trail Westbound					TH 149 Northbound					Wescott Rd Eastbound					Int. Total
	Left	Thru	Rght	Bikes	App. Total	Left	Thru	Rght	Bikes	App. Total	Left	Thru	Rght	Bikes	App. Total	Left	Thru	Rght	Bikes	App. Total	
Peak Hour Analysis From 12:00 to 17:45 - Peak 1 of 1																					
Peak Hour for Entire Intersection Begins at 16:30																					
16:30	1	155	41	0	197	4	5	2	0	11	7	52	7	0	66	11	15	25	0	51	325
16:45	4	146	56	0	206	13	23	0	1	37	11	46	7	0	64	27	21	20	0	68	375
17:00	1	157	54	0	212	8	14	1	0	23	7	67	6	0	80	19	12	16	0	47	362
17:15	1	145	52	0	198	10	8	1	0	19	13	48	1	0	62	26	17	30	0	73	352
Total Volume	7	603	203	0	813	35	50	4	1	90	38	213	21	0	272	83	65	91	0	239	1414
% App. Total	0.9	74.2	25	0		38.9	55.6	4.4	1.1		14	78.3	7.7	0		34.7	27.2	38.1	0		
PHF	.438	.960	.906	.000	.959	.673	.543	.500	.250	.608	.731	.795	.750	.000	.850	.769	.774	.758	.000	.818	.943

