

Alliant Engineering, Inc

233 Park Ave Suite 300

Minneapolis, MN 55415

--TRAFFIC DATA --

Vierling Drive at Tasha Boulevard

Ref.Pt.: Not Available

data by : Alliant Inc.

TURN MOVEMENT COUNT

File Name : 335_Vierling Dr & Tasha Blvd

Site Code : 335

Start Date : 11/8/2017

Page No : 1

Groups Printed- Vehicles - Trucks

| Start Time | Tasha Boulevard From North | | | | Vierling Dr From East | | | | Tasha Boulevard From South | | | | Vierling Dr From West | | | | Int. Total |
|---------------|-------------------------------|------|------|------|--------------------------|------|------|------|-------------------------------|------|------|------|--------------------------|------|------|------|------------|
| | Other | Left | Thru | Rght | Other | Left | Thru | Rght | Other | Left | Thru | Rght | Other | Left | Thru | Rght | |
| 06:00 AM | 0 | 0 | 0 | 0 | 0 | 17 | 9 | 2 | 0 | 0 | 0 | 12 | 0 | 0 | 39 | 8 | 87 |
| 06:15 AM | 0 | 0 | 0 | 0 | 0 | 14 | 5 | 9 | 0 | 0 | 0 | 13 | 0 | 0 | 52 | 2 | 95 |
| 06:30 AM | 0 | 0 | 0 | 0 | 0 | 16 | 17 | 5 | 0 | 0 | 0 | 20 | 0 | 0 | 51 | 6 | 115 |
| 06:45 AM | 0 | 0 | 0 | 0 | 0 | 17 | 24 | 11 | 0 | 0 | 0 | 16 | 0 | 0 | 45 | 8 | 121 |
| Total | 0 | 0 | 0 | 0 | 0 | 64 | 55 | 27 | 0 | 0 | 0 | 61 | 0 | 0 | 187 | 24 | 418 |
| 07:00 AM | 0 | 0 | 0 | 1 | 0 | 29 | 29 | 17 | 0 | 0 | 0 | 26 | 0 | 0 | 85 | 10 | 197 |
| 07:15 AM | 0 | 0 | 0 | 1 | 0 | 17 | 38 | 14 | 0 | 0 | 0 | 23 | 0 | 0 | 78 | 11 | 182 |
| 07:30 AM | 0 | 0 | 0 | 0 | 0 | 24 | 33 | 26 | 0 | 0 | 0 | 26 | 0 | 0 | 84 | 6 | 199 |
| 07:45 AM | 0 | 0 | 0 | 1 | 0 | 29 | 38 | 11 | 0 | 0 | 0 | 18 | 0 | 0 | 69 | 7 | 173 |
| Total | 0 | 0 | 0 | 3 | 0 | 99 | 138 | 68 | 0 | 0 | 0 | 93 | 0 | 0 | 316 | 34 | 751 |
| 08:00 AM | 0 | 0 | 0 | 2 | 0 | 25 | 30 | 23 | 0 | 0 | 0 | 14 | 0 | 0 | 55 | 10 | 159 |
| 08:15 AM | 0 | 0 | 0 | 1 | 0 | 40 | 25 | 19 | 0 | 0 | 0 | 28 | 0 | 0 | 59 | 7 | 179 |
| 08:30 AM | 0 | 0 | 0 | 3 | 0 | 35 | 21 | 16 | 0 | 0 | 0 | 34 | 0 | 0 | 66 | 6 | 181 |
| 08:45 AM | 0 | 0 | 0 | 4 | 0 | 34 | 27 | 20 | 0 | 0 | 0 | 21 | 0 | 0 | 57 | 6 | 169 |
| Total | 0 | 0 | 0 | 10 | 0 | 134 | 103 | 78 | 0 | 0 | 0 | 97 | 0 | 0 | 237 | 29 | 688 |
| 09:00 AM | 0 | 0 | 0 | 5 | 0 | 49 | 29 | 8 | 0 | 0 | 0 | 30 | 0 | 0 | 49 | 8 | 178 |
| 09:15 AM | 0 | 0 | 0 | 4 | 0 | 42 | 24 | 26 | 0 | 0 | 0 | 42 | 0 | 0 | 53 | 8 | 199 |
| *** BREAK *** | | | | | | | | | | | | | | | | | |
| Total | 0 | 0 | 0 | 9 | 0 | 91 | 53 | 34 | 0 | 0 | 0 | 72 | 0 | 0 | 102 | 16 | 377 |
| *** BREAK *** | | | | | | | | | | | | | | | | | |
| 10:30 AM | 0 | 0 | 0 | 4 | 0 | 62 | 25 | 23 | 0 | 0 | 0 | 42 | 0 | 0 | 66 | 7 | 229 |
| 10:45 AM | 0 | 0 | 0 | 4 | 0 | 54 | 45 | 31 | 0 | 0 | 0 | 46 | 0 | 0 | 67 | 5 | 252 |
| Total | 0 | 0 | 0 | 8 | 0 | 116 | 70 | 54 | 0 | 0 | 0 | 88 | 0 | 0 | 133 | 12 | 481 |
| 11:00 AM | 0 | 0 | 0 | 5 | 0 | 50 | 36 | 26 | 0 | 0 | 0 | 49 | 0 | 0 | 66 | 5 | 237 |
| 11:15 AM | 0 | 0 | 0 | 7 | 0 | 62 | 42 | 29 | 0 | 0 | 0 | 54 | 0 | 0 | 67 | 10 | 271 |
| 11:30 AM | 0 | 0 | 0 | 6 | 0 | 66 | 55 | 22 | 0 | 0 | 0 | 46 | 0 | 0 | 78 | 11 | 284 |
| 11:45 AM | 0 | 0 | 0 | 11 | 0 | 80 | 58 | 29 | 0 | 0 | 0 | 52 | 0 | 0 | 72 | 4 | 306 |
| Total | 0 | 0 | 0 | 29 | 0 | 258 | 191 | 106 | 0 | 0 | 0 | 201 | 0 | 0 | 283 | 30 | 1098 |
| 12:00 PM | 0 | 0 | 0 | 8 | 0 | 68 | 64 | 46 | 0 | 0 | 0 | 58 | 0 | 0 | 83 | 9 | 336 |
| 12:15 PM | 0 | 0 | 0 | 15 | 0 | 66 | 86 | 39 | 0 | 0 | 0 | 65 | 0 | 0 | 95 | 8 | 374 |
| 12:30 PM | 0 | 0 | 0 | 8 | 0 | 48 | 41 | 29 | 0 | 0 | 0 | 65 | 0 | 0 | 98 | 8 | 297 |
| 12:45 PM | 0 | 0 | 0 | 5 | 0 | 53 | 51 | 30 | 0 | 0 | 0 | 56 | 0 | 0 | 93 | 3 | 291 |
| Total | 0 | 0 | 0 | 36 | 0 | 235 | 242 | 144 | 0 | 0 | 0 | 244 | 0 | 0 | 369 | 28 | 1298 |
| 01:00 PM | 0 | 0 | 0 | 8 | 0 | 51 | 66 | 22 | 0 | 0 | 0 | 59 | 0 | 0 | 82 | 4 | 292 |
| 01:15 PM | 0 | 0 | 0 | 7 | 0 | 46 | 36 | 29 | 0 | 0 | 0 | 74 | 0 | 0 | 62 | 14 | 268 |
| *** BREAK *** | | | | | | | | | | | | | | | | | |
| Total | 0 | 0 | 0 | 15 | 0 | 97 | 102 | 51 | 0 | 0 | 0 | 133 | 0 | 0 | 144 | 18 | 560 |
| *** BREAK *** | | | | | | | | | | | | | | | | | |
| 02:30 PM | 0 | 0 | 0 | 6 | 0 | 75 | 56 | 26 | 0 | 0 | 0 | 46 | 0 | 0 | 86 | 12 | 307 |
| 02:45 PM | 0 | 0 | 0 | 6 | 0 | 50 | 59 | 21 | 0 | 0 | 0 | 64 | 0 | 0 | 75 | 8 | 283 |
| Total | 0 | 0 | 0 | 12 | 0 | 125 | 115 | 47 | 0 | 0 | 0 | 110 | 0 | 0 | 161 | 20 | 590 |
| 03:00 PM | 0 | 0 | 0 | 6 | 0 | 56 | 87 | 30 | 0 | 0 | 0 | 64 | 0 | 0 | 98 | 7 | 348 |
| 03:15 PM | 0 | 0 | 0 | 10 | 0 | 59 | 53 | 25 | 0 | 0 | 0 | 61 | 0 | 0 | 106 | 14 | 328 |
| 03:30 PM | 0 | 0 | 0 | 14 | 0 | 69 | 62 | 29 | 0 | 0 | 0 | 69 | 0 | 0 | 85 | 5 | 333 |
| 03:45 PM | 0 | 0 | 0 | 6 | 0 | 69 | 76 | 20 | 0 | 0 | 0 | 62 | 0 | 0 | 81 | 11 | 325 |
| Total | 0 | 0 | 0 | 36 | 0 | 253 | 278 | 104 | 0 | 0 | 0 | 256 | 0 | 0 | 370 | 37 | 1334 |
| 04:00 PM | 0 | 0 | 0 | 11 | 0 | 86 | 82 | 25 | 0 | 0 | 0 | 69 | 0 | 0 | 93 | 8 | 374 |
| 04:15 PM | 0 | 0 | 0 | 6 | 0 | 105 | 82 | 34 | 0 | 0 | 0 | 78 | 0 | 0 | 99 | 10 | 414 |
| 04:30 PM | 0 | 0 | 0 | 4 | 0 | 96 | 82 | 29 | 0 | 0 | 0 | 92 | 0 | 0 | 101 | 9 | 413 |
| 04:45 PM | 0 | 0 | 0 | 4 | 0 | 109 | 93 | 39 | 0 | 0 | 0 | 98 | 0 | 0 | 99 | 18 | 460 |
| Total | 0 | 0 | 0 | 25 | 0 | 396 | 339 | 127 | 0 | 0 | 0 | 337 | 0 | 0 | 392 | 45 | 1661 |

Alliant Engineering, Inc

233 Park Ave Suite 300

Minneapolis, MN 55415

--TRAFFIC DATA --

Vierling Drive at Tasha Boulevard

Ref.Pt.: Not Available

data by : Alliant Inc.

TURN MOVEMENT COUNT

File Name : 335_Vierling Dr & Tasha Blvd

Site Code : 335

Start Date : 11/8/2017

Page No : 2

Groups Printed- Vehicles - Trucks

| Start Time | Tasha Boulevard From North | | | | Vierling Dr From East | | | | Tasha Boulevard From South | | | | Vierling Dr From West | | | | Int. Total |
|-------------|-------------------------------|------|------|------|--------------------------|------|------|------|-------------------------------|------|------|------|--------------------------|------|------|------|------------|
| | Other | Left | Thru | Rght | Other | Left | Thru | Rght | Other | Left | Thru | Rght | Other | Left | Thru | Rght | |
| 05:00 PM | 0 | 0 | 0 | 8 | 0 | 80 | 124 | 36 | 0 | 0 | 0 | 101 | 0 | 0 | 105 | 14 | 468 |
| 05:15 PM | 0 | 0 | 0 | 16 | 0 | 88 | 93 | 32 | 0 | 0 | 0 | 81 | 0 | 0 | 102 | 13 | 425 |
| 05:30 PM | 0 | 0 | 0 | 5 | 0 | 62 | 66 | 33 | 0 | 0 | 0 | 74 | 0 | 0 | 95 | 10 | 345 |
| 05:45 PM | 0 | 0 | 0 | 10 | 0 | 71 | 85 | 29 | 0 | 0 | 0 | 74 | 0 | 0 | 98 | 17 | 384 |
| Total | 0 | 0 | 0 | 39 | 0 | 301 | 368 | 130 | 0 | 0 | 0 | 330 | 0 | 0 | 400 | 54 | 1622 |
| Grand Total | 0 | 0 | 0 | 222 | 0 | 2169 | 2054 | 970 | 0 | 0 | 0 | 2022 | 0 | 0 | 3094 | 347 | 10878 |
| Apprch % | 0 | 0 | 0 | 100 | 0 | 41.8 | 39.6 | 18.7 | 0 | 0 | 0 | 100 | 0 | 0 | 89.9 | 10.1 | |
| Total % | 0 | 0 | 0 | 2 | 0 | 19.9 | 18.9 | 8.9 | 0 | 0 | 0 | 18.6 | 0 | 0 | 28.4 | 3.2 | |
| Vehicles | 0 | 0 | 0 | 221 | 0 | 2121 | 2012 | 946 | 0 | 0 | 0 | 1956 | 0 | 0 | 3017 | 342 | 10615 |
| % Vehicles | 0 | 0 | 0 | 99.5 | 0 | 97.8 | 98 | 97.5 | 0 | 0 | 0 | 96.7 | 0 | 0 | 97.5 | 98.6 | 97.6 |
| Trucks | 0 | 0 | 0 | 1 | 0 | 48 | 42 | 24 | 0 | 0 | 0 | 66 | 0 | 0 | 77 | 5 | 263 |
| % Trucks | 0 | 0 | 0 | 0.5 | 0 | 2.2 | 2 | 2.5 | 0 | 0 | 0 | 3.3 | 0 | 0 | 2.5 | 1.4 | 2.4 |

Alliant Engineering, Inc

233 Park Ave Suite 300
 Minneapolis, MN 55415
 --TRAFFIC DATA --

Vierling Drive at Tasha Boulevard
 Ref.Pt.: Not Available
 data by : Alliant Inc.
 TURN MOVEMENT COUNT

File Name : 335_Vierling Dr & Tasha Blvd
 Site Code : 335
 Start Date : 11/8/2017
 Page No : 3

| Start Time | Tasha Boulevard From North | | | | | Vierling Dr From East | | | | | Tasha Boulevard From South | | | | | Vierling Dr From West | | | | | Int. Total |
|--|----------------------------|------|------|-------|------------|-----------------------|------|------|-------|------------|----------------------------|------|------|-------|------------|-----------------------|------|------|-------|------------|------------|
| | Other | Left | Thru | Right | App. Total | Other | Left | Thru | Right | App. Total | Other | Left | Thru | Right | App. Total | Other | Left | Thru | Right | App. Total | |
| Peak Hour Analysis From 06:00 AM to 11:45 AM - Peak 1 of 1 | | | | | | | | | | | | | | | | | | | | | |
| Peak Hour for Entire Intersection Begins at 11:00 AM | | | | | | | | | | | | | | | | | | | | | |
| 11:00 AM | 0 | 0 | 0 | 5 | 5 | 0 | 50 | 36 | 26 | 112 | 0 | 0 | 0 | 49 | 49 | 0 | 0 | 66 | 5 | 71 | 237 |
| 11:15 AM | 0 | 0 | 0 | 7 | 7 | 0 | 62 | 42 | 29 | 133 | 0 | 0 | 0 | 54 | 54 | 0 | 0 | 67 | 10 | 77 | 271 |
| 11:30 AM | 0 | 0 | 0 | 6 | 6 | 0 | 66 | 55 | 22 | 143 | 0 | 0 | 0 | 46 | 46 | 0 | 0 | 78 | 11 | 89 | 284 |
| 11:45 AM | 0 | 0 | 0 | 11 | 11 | 0 | 80 | 58 | 29 | 167 | 0 | 0 | 0 | 52 | 52 | 0 | 0 | 72 | 4 | 76 | 306 |
| Total Volume | 0 | 0 | 0 | 29 | 29 | 0 | 258 | 191 | 106 | 555 | 0 | 0 | 0 | 201 | 201 | 0 | 0 | 283 | 30 | 313 | 1098 |
| % App. Total | 0 | 0 | 0 | 100 | | 0 | 46.5 | 34.4 | 19.1 | | 0 | 0 | 0 | 100 | | 0 | 0 | 90.4 | 9.6 | | |
| PHF | .000 | .000 | .000 | .659 | .659 | .000 | .806 | .823 | .914 | .831 | .000 | .000 | .000 | .931 | .931 | .000 | .000 | .907 | .682 | .879 | .897 |

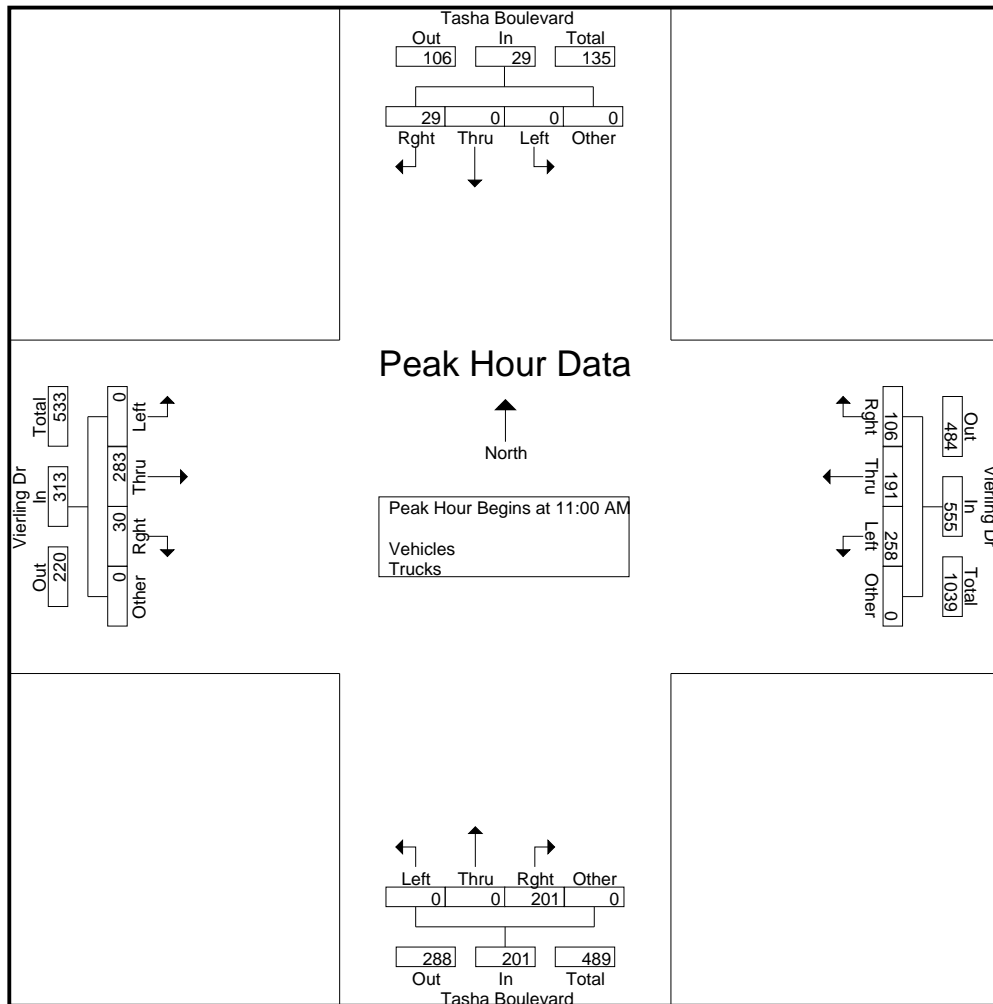

Alliant Engineering, Inc

233 Park Ave Suite 300
 Minneapolis, MN 55415
 --TRAFFIC DATA --

Vierling Drive at Tasha Boulevard
 Ref.Pt.: Not Available
 data by : Alliant Inc.
 TURN MOVEMENT COUNT

File Name : 335_Vierling Dr & Tasha Blvd
 Site Code : 335
 Start Date : 11/8/2017
 Page No : 4

| Start Time | Tasha Boulevard From North | | | | | Vierling Dr From East | | | | | Tasha Boulevard From South | | | | | Vierling Dr From West | | | | | Int. Total |
|--|----------------------------|------|------|------|------------|-----------------------|------|------|------|------------|----------------------------|------|------|------|------------|-----------------------|------|------|------|------------|------------|
| | Other | Left | Thru | Rght | App. Total | Other | Left | Thru | Rght | App. Total | Other | Left | Thru | Rght | App. Total | Other | Left | Thru | Rght | App. Total | |
| Peak Hour Analysis From 12:00 PM to 05:45 PM - Peak 1 of 1 | | | | | | | | | | | | | | | | | | | | | |
| Peak Hour for Entire Intersection Begins at 04:30 PM | | | | | | | | | | | | | | | | | | | | | |
| 04:30 PM | 0 | 0 | 0 | 4 | 4 | 0 | 96 | 82 | 29 | 207 | 0 | 0 | 0 | 92 | 92 | 0 | 0 | 101 | 9 | 110 | 413 |
| 04:45 PM | 0 | 0 | 0 | 4 | 4 | 0 | 109 | 93 | 39 | 241 | 0 | 0 | 0 | 98 | 98 | 0 | 0 | 99 | 18 | 117 | 460 |
| 05:00 PM | 0 | 0 | 0 | 8 | 8 | 0 | 80 | 124 | 36 | 240 | 0 | 0 | 0 | 101 | 101 | 0 | 0 | 105 | 14 | 119 | 468 |
| 05:15 PM | 0 | 0 | 0 | 16 | 16 | 0 | 88 | 93 | 32 | 213 | 0 | 0 | 0 | 81 | 81 | 0 | 0 | 102 | 13 | 115 | 425 |
| Total Volume | 0 | 0 | 0 | 32 | 32 | 0 | 373 | 392 | 136 | 901 | 0 | 0 | 0 | 372 | 372 | 0 | 0 | 407 | 54 | 461 | 1766 |
| % App. Total | 0 | 0 | 0 | 100 | | 0 | 41.4 | 43.5 | 15.1 | | 0 | 0 | 0 | 100 | | 0 | 0 | 88.3 | 11.7 | | |
| PHF | .000 | .000 | .000 | .500 | .500 | .000 | .856 | .790 | .872 | .935 | .000 | .000 | .000 | .921 | .921 | .000 | .000 | .969 | .750 | .968 | .943 |

