



# MINNESOTA DEPT OF TRANSPORTATION

## TRAFFIC DATA COLLECTION - METRO

TH-169 at 101st Ave. N  
 REF.PT.: 141.815  
 JAMAR # 633/D4-3358 DR/KF  
 TURN MOVEMENT COUNT

File Name : TH-169 AT 101ST AVE N 2007  
 Site Code : 00000000  
 Start Date : 5/2/2007  
 Page No : 1

### Groups Printed- Cars & Trucks

Start Time	TH-169 Southbound				101st AVE N. Westbound				TH-169 Northbound				101st AVE N. Eastbound				Int. Total
	Left	Thru	Right	Peds	Left	Thru	Right	Peds	Left	Thru	Right	Peds	Left	Thru	Right	Peds	
06:00	1	591	5	0	1	0	0	0	6	32	0	0	1	1	11	0	649
06:15	7	572	31	0	0	0	0	0	23	158	1	0	0	3	22	0	817
06:30	13	499	49	0	0	0	0	0	38	209	0	0	0	2	19	0	829
06:45	6	562	30	0	0	1	0	0	50	213	0	0	0	0	38	0	900
<b>Total</b>	<b>27</b>	<b>2224</b>	<b>115</b>	<b>0</b>	<b>1</b>	<b>1</b>	<b>0</b>	<b>0</b>	<b>117</b>	<b>612</b>	<b>1</b>	<b>0</b>	<b>1</b>	<b>6</b>	<b>90</b>	<b>0</b>	<b>3195</b>
07:00	4	584	30	0	0	1	0	0	59	188	2	0	0	0	21	0	889
07:15	19	484	84	0	1	0	0	0	68	253	0	0	1	1	39	0	950
07:30	9	499	65	0	0	3	0	0	84	308	0	0	2	1	51	0	1022
07:45	9	431	41	0	0	0	0	0	90	265	0	0	4	1	23	0	864
<b>Total</b>	<b>41</b>	<b>1998</b>	<b>220</b>	<b>0</b>	<b>1</b>	<b>4</b>	<b>0</b>	<b>0</b>	<b>301</b>	<b>1014</b>	<b>2</b>	<b>0</b>	<b>7</b>	<b>3</b>	<b>134</b>	<b>0</b>	<b>3725</b>
08:00	5	468	20	0	0	0	0	0	74	222	1	0	3	2	37	0	832
08:15	5	520	22	0	0	0	0	0	47	217	5	0	0	1	30	0	847
08:30	5	385	23	0	1	2	0	0	34	219	4	0	1	0	36	0	710
08:45	3	280	11	0	0	1	2	0	49	191	1	0	5	1	19	0	563
<b>Total</b>	<b>18</b>	<b>1653</b>	<b>76</b>	<b>0</b>	<b>1</b>	<b>3</b>	<b>2</b>	<b>0</b>	<b>204</b>	<b>849</b>	<b>11</b>	<b>0</b>	<b>9</b>	<b>4</b>	<b>122</b>	<b>0</b>	<b>2952</b>
*** BREAK ***																	
15:00	2	297	7	0	0	0	0	0	35	407	1	0	4	0	17	0	770
15:15	0	298	4	0	0	0	1	0	34	462	0	0	1	2	24	0	826
15:30	3	296	2	0	1	0	1	0	43	484	1	0	6	1	30	0	868
15:45	1	312	7	0	0	0	0	0	61	501	2	0	6	2	37	0	929
<b>Total</b>	<b>6</b>	<b>1203</b>	<b>20</b>	<b>0</b>	<b>1</b>	<b>0</b>	<b>2</b>	<b>0</b>	<b>173</b>	<b>1854</b>	<b>4</b>	<b>0</b>	<b>17</b>	<b>5</b>	<b>108</b>	<b>0</b>	<b>3393</b>
16:00	0	299	10	0	1	0	0	0	45	532	0	0	2	0	44	0	933
16:15	3	305	6	0	0	1	1	0	42	457	1	0	1	3	47	0	867
16:30	0	352	13	0	1	2	0	0	60	433	2	0	3	0	43	0	909
16:45	2	352	7	0	0	0	0	0	64	487	2	0	3	2	35	0	954
<b>Total</b>	<b>5</b>	<b>1308</b>	<b>36</b>	<b>0</b>	<b>2</b>	<b>3</b>	<b>1</b>	<b>0</b>	<b>211</b>	<b>1909</b>	<b>5</b>	<b>0</b>	<b>9</b>	<b>5</b>	<b>169</b>	<b>0</b>	<b>3663</b>
17:00	1	376	9	0	0	1	1	0	50	457	0	0	3	2	56	0	956
17:15	2	334	16	0	1	1	0	0	63	482	1	0	0	0	39	0	939
17:30	0	378	15	0	0	5	1	0	63	469	2	0	4	1	47	0	985
17:45	3	320	9	0	1	3	1	0	61	463	1	0	0	2	38	0	902
<b>Total</b>	<b>6</b>	<b>1408</b>	<b>49</b>	<b>0</b>	<b>2</b>	<b>10</b>	<b>3</b>	<b>0</b>	<b>237</b>	<b>1871</b>	<b>4</b>	<b>0</b>	<b>7</b>	<b>5</b>	<b>180</b>	<b>0</b>	<b>3782</b>
<b>Grand Total</b>	<b>103</b>	<b>9794</b>	<b>516</b>	<b>0</b>	<b>8</b>	<b>21</b>	<b>8</b>	<b>0</b>	<b>1243</b>	<b>8109</b>	<b>27</b>	<b>0</b>	<b>50</b>	<b>28</b>	<b>803</b>	<b>0</b>	<b>20710</b>
Apprch %	1	94.1	5	0	21.6	56.8	21.6	0	13.3	86.5	0.3	0	5.7	3.2	91.1	0	
Total %	0.5	47.3	2.5	0	0	0.1	0	0	6	39.2	0.1	0	0.2	0.1	3.9	0	



# MINNESOTA DEPT OF TRANSPORTATION

## TRAFFIC DATA COLLECTION - METRO

TH-169 at 101st Ave. N  
 REF.PT.: 141.815  
 JAMAR # 633/D4-3358 DR/KF  
 TURN MOVEMENT COUNT

File Name : TH-169 AT 101ST AVE N 2007  
 Site Code : 00000000  
 Start Date : 5/2/2007  
 Page No : 2

Start Time	TH-169 Southbound					101st AVE N. Westbound					TH-169 Northbound					101st AVE N. Eastbound					Int. Total
	Left	Thru	Right	Peds	App. Total	Left	Thru	Right	Peds	App. Total	Left	Thru	Right	Peds	App. Total	Left	Thru	Right	Peds	App. Total	
Peak Hour Analysis From 06:00 to 08:45 - Peak 1 of 1																					
Peak Hour for Entire Intersection Begins at 06:45																					
06:45	6	562	30	0	598	0	1	0	0	1	50	213	0	0	263	0	0	38	0	38	900
07:00	4	<b>584</b>	30	0	<b>618</b>	0	1	0	0	1	59	188	2	0	249	0	0	21	0	21	889
07:15	<b>19</b>	484	<b>84</b>	0	587	<b>1</b>	0	0	0	1	68	253	0	0	321	1	<b>1</b>	39	0	41	950
07:30	9	499	65	0	573	0	<b>3</b>	0	0	<b>3</b>	<b>84</b>	<b>308</b>	0	0	<b>392</b>	<b>2</b>	<b>1</b>	<b>51</b>	0	<b>54</b>	<b>1022</b>
Total Volume	38	2129	209	0	2376	1	5	0	0	6	261	962	2	0	1225	3	2	149	0	154	3761
% App. Total	1.6	89.6	8.8	0		16.7	83.3	0	0		21.3	78.5	0.2	0		1.9	1.3	96.8	0		
PHF	.500	.911	.622	.000	.961	.250	.417	.000	.000	.500	.777	.781	.250	.000	.781	.375	.500	.730	.000	.713	.920

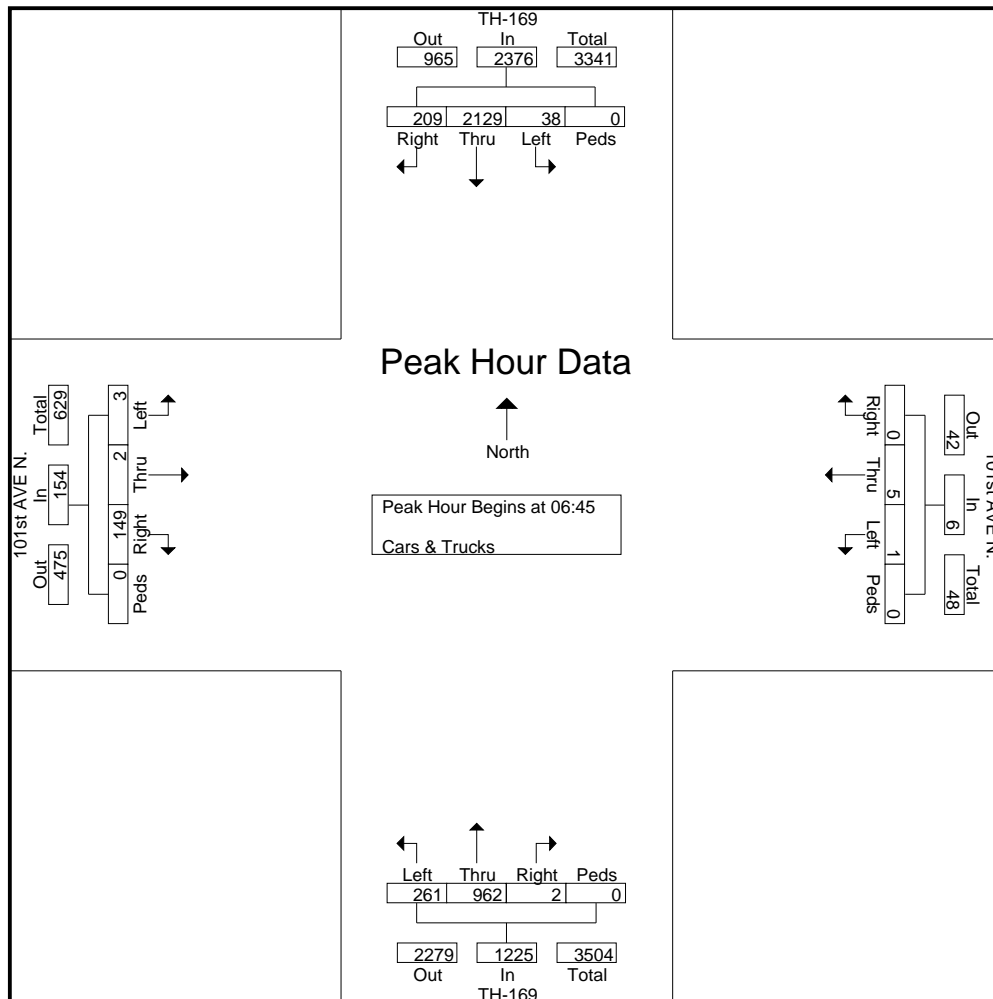



# MINNESOTA DEPT OF TRANSPORTATION

## TRAFFIC DATA COLLECTION - METRO

TH-169 at 101st Ave. N  
 REF.PT.: 141.815  
 JAMAR # 633/D4-3358 DR/KF  
 TURN MOVEMENT COUNT

File Name : TH-169 AT 101ST AVE N 2007  
 Site Code : 00000000  
 Start Date : 5/2/2007  
 Page No : 3

Start Time	TH-169 Southbound					101st AVE N. Westbound					TH-169 Northbound					101st AVE N. Eastbound					Int. Total
	Left	Thru	Right	Peds	App. Total	Left	Thru	Right	Peds	App. Total	Left	Thru	Right	Peds	App. Total	Left	Thru	Right	Peds	App. Total	
Peak Hour Analysis From 15:00 to 17:45 - Peak 1 of 1																					
Peak Hour for Entire Intersection Begins at 16:45																					
16:45	2	352	7	0	361	0	0	0	0	0	64	487	2	0	553	3	2	35	0	40	954
17:00	1	376	9	0	386	0	1	1	0	2	50	457	0	0	507	3	2	56	0	61	956
17:15	2	334	16	0	352	1	1	0	0	2	63	482	1	0	546	0	0	39	0	39	939
17:30	0	378	15	0	393	0	5	1	0	6	63	469	2	0	534	4	1	47	0	52	985
Total Volume	5	1440	47	0	1492	1	7	2	0	10	240	1895	5	0	2140	10	5	177	0	192	3834
% App. Total	0.3	96.5	3.2	0		10	70	20	0		11.2	88.6	0.2	0		5.2	2.6	92.2	0		
PHF	.625	.952	.734	.000	.949	.250	.350	.500	.000	.417	.938	.973	.625	.000	.967	.625	.625	.790	.000	.787	.973

