

SEH CONSULTING
Traffic Data Collection
TURN MOVEMENT COUNT

TH 36 at Hadley Avenue N
Ref.Pt.: 011.260
data by SEH
TURN MOVEMENT COUNT

File Name : TH-36 at Hadley Ave N 2008
Site Code : 00000004
Start Date : 12/11/2008
Page No : 1

Groups Printed- Unshifted - Heavy Veh

Start Time	Hadley Ave N Southbound				TH-36 Westbound				Hadley Ave N Northbound				TH-36 Eastbound				Int. Total
	Left	Thru	Right	Peds	Left	Thru	Right	Peds	Left	Thru	Right	Peds	Left	Thru	Right	Peds	
06:00	4	2	2	0	12	154	10	0	22	5	25	0	2	42	4	1	285
06:15	9	8	12	1	9	234	11	0	30	10	35	0	2	68	5	0	434
06:30	12	10	7	0	7	267	18	0	29	6	46	0	1	109	8	0	520
06:45	27	6	7	0	16	352	15	0	40	10	35	0	3	112	8	0	631
Total	52	26	28	1	44	1007	54	0	121	31	141	0	8	331	25	1	1870
07:00	16	10	6	0	8	367	10	0	55	21	59	0	5	105	13	0	675
07:15	6	5	10	0	17	371	17	0	52	23	49	0	4	154	4	0	712
07:30	13	16	10	0	19	300	21	0	42	19	44	0	7	168	17	0	676
07:45	12	26	11	0	29	357	39	0	60	23	34	0	5	213	18	0	827
Total	47	57	37	0	73	1395	87	0	209	86	186	0	21	640	52	0	2890
08:00	9	10	11	0	32	324	29	0	53	21	33	0	8	164	16	0	710
08:15	14	9	10	0	22	242	21	0	32	18	42	0	10	151	13	0	584
08:30	16	15	8	0	11	283	26	0	25	17	38	0	13	161	7	0	620
08:45	13	11	14	0	8	245	22	0	40	16	40	0	19	157	11	0	596
Total	52	45	43	0	73	1094	98	0	150	72	153	0	50	633	47	0	2510
*** BREAK ***																	
11:00	37	18	34	0	13	152	48	0	10	16	20	0	32	134	17	0	531
11:15	33	20	23	0	6	181	52	0	20	16	17	0	26	128	15	0	537
11:30	42	24	32	0	11	125	74	8	12	19	20	0	40	145	9	0	561
11:45	38	21	29	0	7	130	51	0	21	20	16	0	37	128	19	0	517
Total	150	83	118	0	37	588	225	8	63	71	73	0	135	535	60	0	2146
12:00	29	23	37	0	24	146	56	0	17	19	14	0	32	155	19	1	572
12:15	48	33	23	0	14	150	46	0	13	18	19	0	33	145	19	1	562
12:30	39	25	21	0	25	140	39	1	16	17	18	0	35	159	14	0	549
12:45	60	22	26	0	18	156	58	0	16	16	14	0	35	141	21	0	583
Total	176	103	107	0	81	592	199	1	62	70	65	0	135	600	73	2	2266
*** BREAK ***																	
15:00	58	34	29	0	19	171	46	0	22	24	35	1	42	271	36	0	788
15:15	51	34	38	0	24	187	65	1	28	31	39	0	37	260	28	0	823
15:30	60	27	24	0	16	187	60	0	32	31	42	0	28	291	37	0	835
15:45	44	25	27	0	22	192	51	0	20	24	27	0	51	325	38	0	846
Total	213	120	118	0	81	737	222	1	102	110	143	1	158	1147	139	0	3292
16:00	76	47	23	0	28	156	53	0	28	36	34	0	41	301	28	0	851
16:15	68	55	23	0	33	174	49	1	22	19	26	0	38	378	48	0	934
16:30	63	44	22	0	28	170	69	1	36	30	30	0	48	354	38	0	933
16:45	56	40	31	0	29	197	52	0	22	34	32	0	31	383	37	0	944
Total	263	186	99	0	118	697	223	2	108	119	122	0	158	1416	151	0	3662
17:00	60	30	13	0	48	198	54	0	21	26	38	0	31	384	32	0	935
17:15	62	41	28	0	30	177	73	1	41	27	30	0	36	324	34	0	904
17:30	52	44	15	0	20	173	55	0	30	21	38	0	31	348	35	0	862
17:45	44	29	24	0	32	163	37	0	22	25	26	0	53	342	28	1	826
Total	218	144	80	0	130	711	219	1	114	99	132	0	151	1398	129	1	3527
Grand Total	1171	764	630	1	637	6821	1327	13	929	658	1015	1	816	6700	676	4	22163
Apprch %	45.6	29.8	24.6	0	7.2	77.5	15.1	0.1	35.7	25.3	39	0	10	81.7	8.2	0	
Total %	5.3	3.4	2.8	0	2.9	30.8	6	0.1	4.2	3	4.6	0	3.7	30.2	3.1	0	
Unshifted	1171	764	630	1	637	6820	1327	13	925	656	1005	1	813	6632	669	4	22068
% Unshifted	100	100	100	100	100	100	100	100	99.6	99.7	99	100	99.6	99	99	100	99.6
Heavy Veh	0	0	0	0	0	1	0	0	4	2	10	0	3	68	7	0	95
% Heavy Veh	0	0	0	0	0	0	0	0	0.4	0.3	1	0	0.4	1	1	0	0.4

SEH CONSULTING
Traffic Data Collection
TURN MOVEMENT COUNT

TH 36 at Hadley Avenue N
Ref.Pt.: 011.260
data by SEH
TURN MOVEMENT COUNT

File Name : TH-36 at Hadley Ave N 2008
Site Code : 00000004
Start Date : 12/11/2008
Page No : 2

Start Time	Hadley Ave N Southbound					TH-36 Westbound					Hadley Ave N Northbound					TH-36 Eastbound					Int. Total
	Left	Thru	Right	Peds	App. Total	Left	Thru	Right	Peds	App. Total	Left	Thru	Right	Peds	App. Total	Left	Thru	Right	Peds	App. Total	
Peak Hour Analysis From 06:00 to 08:45 - Peak 1 of 1																					
Peak Hour for Entire Intersection Begins at 07:15																					
07:15	6	5	10	0	21	17	371	17	0	405	52	23	49	0	124	4	154	4	0	162	712
07:30	13	16	10	0	39	19	300	21	0	340	42	19	44	0	105	7	168	17	0	192	676
07:45	12	26	11	0	49	29	357	39	0	425	60	23	34	0	117	5	213	18	0	236	827
08:00	9	10	11	0	30	32	324	29	0	385	53	21	33	0	107	8	164	16	0	188	710
Total Volume	40	57	42	0	139	97	1352	106	0	1555	207	86	160	0	453	24	699	55	0	778	2925
% App. Total	28.8	41	30.2	0		6.2	86.9	6.8	0		45.7	19	35.3	0		3.1	89.8	7.1	0		
PHF	.769	.548	.955	.000	.709	.758	.911	.679	.000	.915	.863	.935	.816	.000	.913	.750	.820	.764	.000	.824	.884

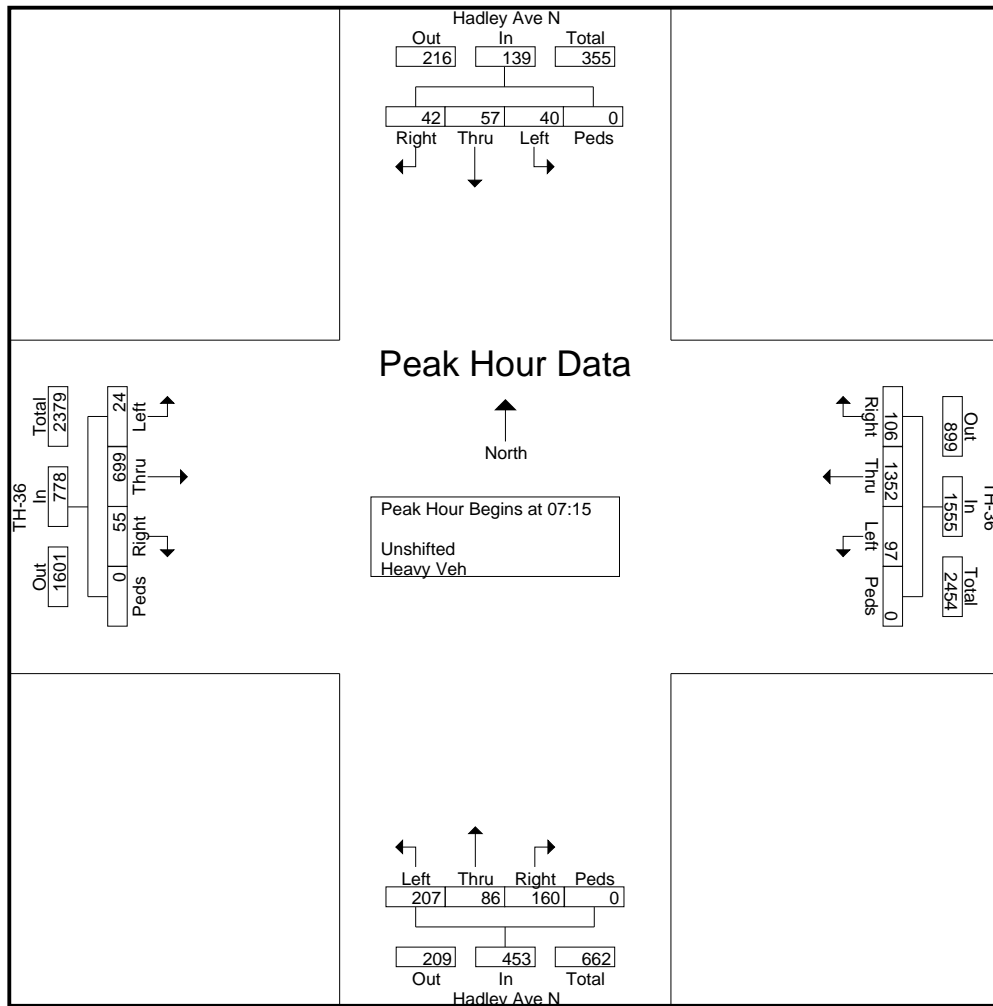

SEH CONSULTING
Traffic Data Collection
TURN MOVEMENT COUNT

TH 36 at Hadley Avenue N
Ref.Pt.: 011.260
data by SEH
TURN MOVEMENT COUNT

File Name : TH-36 at Hadley Ave N 2008
Site Code : 00000004
Start Date : 12/11/2008
Page No : 3

Start Time	Hadley Ave N Southbound					TH-36 Westbound					Hadley Ave N Northbound					TH-36 Eastbound					Int. Total
	Left	Thru	Right	Peds	App. Total	Left	Thru	Right	Peds	App. Total	Left	Thru	Right	Peds	App. Total	Left	Thru	Right	Peds	App. Total	
Peak Hour Analysis From 15:00 to 17:45 - Peak 1 of 1																					
Peak Hour for Entire Intersection Begins at 16:15																					
16:15	68	55	23	0	146	33	174	49	1	257	22	19	26	0	67	38	378	48	0	464	934
16:30	63	44	22	0	129	28	170	69	1	268	36	30	30	0	96	48	354	38	0	440	933
16:45	56	40	31	0	127	29	197	52	0	278	22	34	32	0	88	31	383	37	0	451	944
17:00	60	30	13	0	103	48	198	54	0	300	21	26	38	0	85	31	384	32	0	447	935
Total Volume	247	169	89	0	505	138	739	224	2	1103	101	109	126	0	336	148	1499	155	0	1802	3746
% App. Total	48.9	33.5	17.6	0		12.5	67	20.3	0.2		30.1	32.4	37.5	0		8.2	83.2	8.6	0		
PHF	.908	.768	.718	.000	.865	.719	.933	.812	.500	.919	.701	.801	.829	.000	.875	.771	.976	.807	.000	.971	.992

