



MINNESOTA DEPT OF TRANSPORTATION

TRAFFIC DATA COLLECTION - METRO

TH-41 at Canyon Rd CHASKA

Ref.Pt.: 003.634

video SP

TURN MOVEMENT COUNT - AM + NOON

File Name : TH-41 at Canyon Rd 2013

Site Code :

Start Date : 10/23/2013

Page No : 1

Groups Printed- Cars +

Start Time	TH 41 Southbound				Canyon Westbound				TH 41 Northbound				Canyon Eastbound				Int. Total
	Right	Thru	Left	Peds	Right	Thru	Left	Peds	Right	Thru	Left	Peds	Right	Thru	Left	Peds	
06:00	21	54	0	0	0	0	1	0	0	89	6	0	1	0	3	0	175
06:15	25	48	0	0	2	0	0	0	1	165	7	0	1	0	4	0	253
06:30	27	86	0	0	4	0	1	0	0	168	12	0	1	0	7	0	306
06:45	33	107	0	0	3	0	1	0	0	261	14	0	3	0	3	0	425
Total	106	295	0	0	9	0	3	0	1	683	39	0	6	0	17	0	1159
07:00	20	154	1	0	9	0	0	0	1	237	15	0	1	0	7	0	445
07:15	21	165	1	0	1	0	3	0	1	322	10	0	4	0	5	0	533
07:30	19	126	1	0	3	0	2	0	3	248	7	0	0	0	4	0	413
07:45	21	151	2	0	9	0	4	0	1	324	6	0	1	0	8	0	527
Total	81	596	5	0	22	0	9	0	6	1131	38	0	6	0	24	0	1918
08:00	13	153	2	0	5	0	0	0	1	229	4	0	1	0	1	0	409
08:15	9	125	2	0	3	0	0	0	0	235	1	0	0	0	3	0	378
08:30	4	159	1	0	3	0	0	0	1	187	2	0	2	0	3	0	362
08:45	5	130	1	0	3	0	3	0	1	208	1	0	0	0	4	0	356
Total	31	567	6	0	14	0	3	0	3	859	8	0	3	0	11	0	1505
09:00	1	116	0	0	5	0	1	0	0	193	3	0	0	0	1	0	320
09:15	3	160	2	0	1	0	1	0	1	137	1	0	1	0	2	0	309
***** BREACK *****																	
Total	4	276	2	0	6	0	2	0	1	330	4	0	1	0	3	0	629
***** BREACK *****																	
10:30	2	121	2	0	0	0	1	0	0	145	0	0	0	0	0	0	271
10:45	0	130	1	0	0	0	0	0	0	133	2	0	1	0	1	0	268
Total	2	251	3	0	0	0	1	0	0	278	2	0	1	0	1	0	539
11:00	0	125	0	0	3	0	1	0	2	133	0	0	0	0	0	0	264
11:15	1	141	3	0	2	0	0	0	1	153	2	0	0	0	0	0	303
11:30	2	129	0	0	1	0	0	0	1	141	0	0	1	0	3	0	278
11:45	0	157	2	0	0	0	0	0	0	131	0	0	0	0	1	0	291
Total	3	552	5	0	6	0	1	0	4	558	2	0	1	0	4	0	1136
12:00	2	141	2	0	1	0	0	0	2	130	0	0	0	0	1	0	279
12:15	0	127	0	0	1	0	0	0	0	141	1	0	0	0	1	0	271
12:30	2	129	2	0	2	0	0	0	0	155	0	0	1	0	1	0	292
12:45	0	139	2	0	3	0	1	0	0	158	1	0	0	0	2	0	306
Total	4	536	6	0	7	0	1	0	2	584	2	0	1	0	5	0	1148
***** BREACK *****																	
15:00	2	191	1	0	1	0	0	0	1	152	1	0	3	0	4	0	356
15:15	1	222	3	0	1	0	2	0	0	182	0	0	1	0	1	0	413
15:30	3	244	3	0	5	0	2	0	2	167	0	0	2	0	4	0	432
15:45	1	263	1	0	1	0	0	0	0	199	1	0	0	0	3	0	469
Total	7	920	8	0	8	0	4	0	3	700	2	0	6	0	12	0	1670
16:00	2	252	4	0	1	0	1	0	1	237	1	0	3	0	3	0	505
16:15	7	264	6	0	1	0	0	0	4	214	1	0	3	0	4	0	504
16:30	2	245	4	0	2	0	0	0	1	221	0	0	28	0	13	0	516
16:45	4	269	7	0	1	0	0	0	0	198	0	0	9	0	7	0	495
Total	15	1030	21	0	5	0	1	0	6	870	2	0	43	0	27	0	2020



MINNESOTA DEPT OF TRANSPORTATION

TRAFFIC DATA COLLECTION - METRO

TH-41 at Canyon Rd CHASKA

Ref.Pt.: 003.634

video SP

TURN MOVEMENT COUNT - AM + NOON

File Name : TH-41 at Canyon Rd 2013

Site Code :

Start Date : 10/23/2013

Page No : 2

Groups Printed- Cars +

Start Time	TH 41 Southbound				Canyon Westbound				TH 41 Northbound				Canyon Eastbound				Int. Total
	Right	Thru	Left	Peds	Right	Thru	Left	Peds	Right	Thru	Left	Peds	Right	Thru	Left	Peds	
17:00	8	269	3	0	3	0	0	0	0	214	2	0	31	0	29	0	559
17:15	2	256	5	0	3	0	0	0	0	197	2	0	15	0	5	0	485
17:30	7	269	4	0	4	0	0	0	0	199	1	0	24	0	19	0	527
17:45	8	255	5	0	4	0	0	0	1	212	0	0	13	0	22	0	520
Total	25	1049	17	0	14	0	0	0	1	822	5	0	83	0	75	0	2091
Grand Total	278	6072	73	0	91	0	25	0	27	6815	104	0	151	0	179	0	13815
Apprch %	4.3	94.5	1.1	0	78.4	0	21.6	0	0.4	98.1	1.5	0	45.8	0	54.2	0	
Total %	2	44	0.5	0	0.7	0	0.2	0	0.2	49.3	0.8	0	1.1	0	1.3	0	



MINNESOTA DEPT OF TRANSPORTATION

TRAFFIC DATA COLLECTION - METRO

TH-41 at Canyon Rd CHASKA
 Ref.Pt.: 003.634
 video SP
 TURN MOVEMENT COUNT - AM + NOON

File Name : TH-41 at Canyon Rd 2013
 Site Code :
 Start Date : 10/23/2013
 Page No : 3

Start Time	TH 41 Southbound					Canyon Westbound					TH 41 Northbound					Canyon Eastbound					Int. Total
	Right	Thru	Left	Peds	App. Total	Right	Thru	Left	Peds	App. Total	Right	Thru	Left	Peds	App. Total	Right	Thru	Left	Peds	App. Total	
Peak Hour Analysis From 06:00 to 09:15 - Peak 1 of 1																					
Peak Hour for Entire Intersection Begins at 07:00																					
07:00	20	154	1	0	175	9	0	0	0	9	1	237	15	0	253	1	0	7	0	8	445
07:15	21	165	1	0	187	1	0	3	0	4	1	322	10	0	333	4	0	5	0	9	533
07:30	19	126	1	0	146	3	0	2	0	5	3	248	7	0	258	0	0	4	0	4	413
07:45	21	151	2	0	174	9	0	4	0	13	1	324	6	0	331	1	0	8	0	9	527
Total Volume	81	596	5	0	682	22	0	9	0	31	6	1131	38	0	1175	6	0	24	0	30	1918
% App. Total	11.9	87.4	0.7	0		71	0	29	0		0.5	96.3	3.2	0		20	0	80	0		
PHF	.964	.903	.625	.000	.912	.611	.000	.563	.000	.596	.500	.873	.633	.000	.882	.375	.000	.750	.000	.833	.900

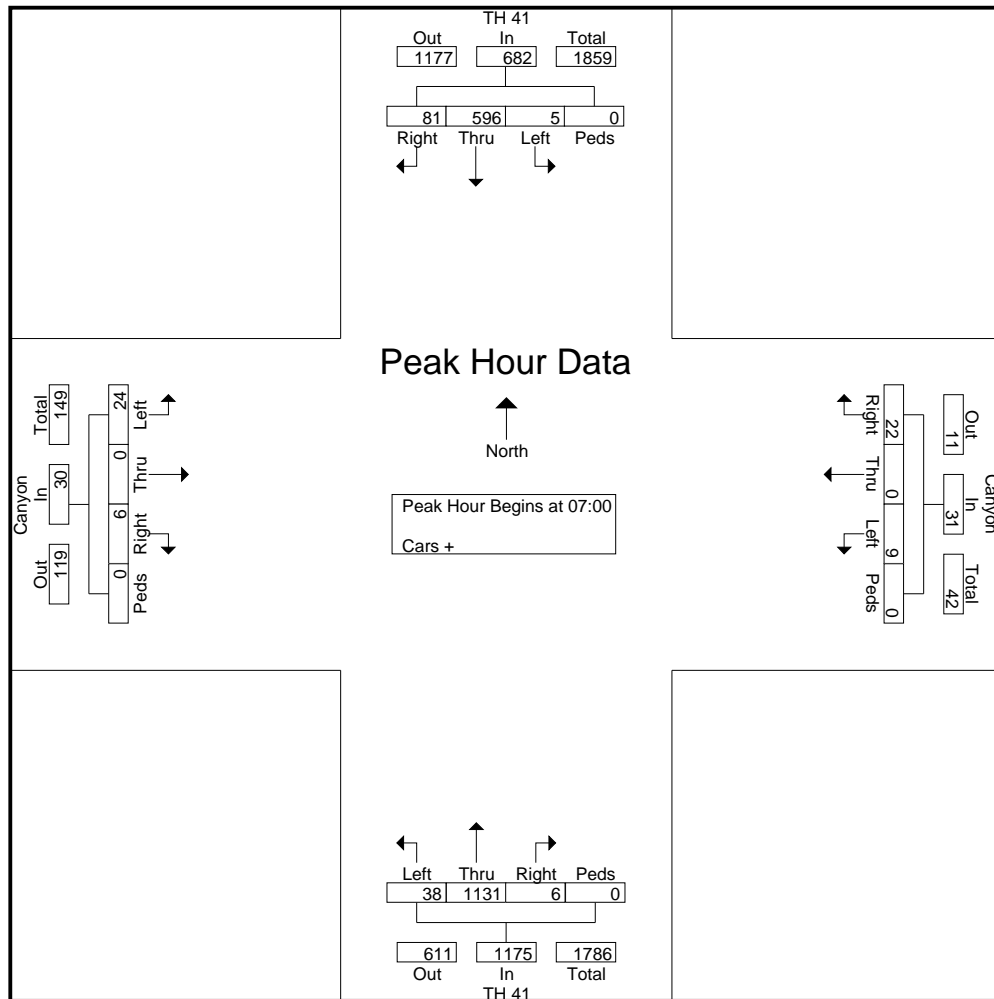



MINNESOTA DEPT OF TRANSPORTATION

TRAFFIC DATA COLLECTION - METRO

TH-41 at Canyon Rd CHASKA

Ref.Pt.: 003.634

video SP

TURN MOVEMENT COUNT - AM + NOON

File Name : TH-41 at Canyon Rd 2013

Site Code :

Start Date : 10/23/2013

Page No : 4

Start Time	TH 41 Southbound					Canyon Westbound					TH 41 Northbound					Canyon Eastbound					Int. Total
	Rig ht	Thr u	Left	Ped s	App. Total	Rig ht	Thr u	Left	Ped s	App. Total	Right	Thr u	Left	Peds	App. Total	Right	Thr u	Left	Peds	App. Total	
Peak Hour Analysis From 15:00 to 17:45 - Peak 1 of 1																					
Peak Hour for Entire Intersection Begins at 17:00																					
17:00	8	269	3	0	280	3	0	0	0	3	0	214	2	0	216	31	0	29	0	60	559
17:15	2	256	5	0	263	3	0	0	0	3	0	197	2	0	199	15	0	5	0	20	485
17:30	7	269	4	0	280	4	0	0	0	4	0	199	1	0	200	24	0	19	0	43	527
17:45	8	255	5	0	268	4	0	0	0	4	1	212	0	0	213	13	0	22	0	35	520
Total Volume	25	1049	17	0	1091	14	0	0	0	14	1	822	5	0	828	83	0	75	0	158	2091
% App. Total	2.3	96.2	1.6	0		100	0	0	0		0.1	99.3	0.6	0		52.5	0	47.5	0		
PHF	.781	.975	.850	.000	.974	.875	.000	.000	.000	.875	.250	.960	.625	.000	.958	.669	.000	.647	.000	.658	.935

