

ALLIANT ENGINEERING, INC.

733 S Marquette Ave #700, Minneapolis, MN 55402

Intersection: TH 47 & 40th Avenue
Date: 3/19/2024
Duration: 0600-1800

Site Code: 602
Ref Pt: N/A
Page No: 1 of 4

All Vehicles (Cars & Trucks) Printed

Start Time	TH 47 Southbound						40th Avenue Westbound						TH 47 Northbound						40th Avenue Eastbound						Int. Veh. Total	Int. Ped/ Bike Total
	U-Turn	Left	Thru	Right	App. Total	Peds/ Bikes	U-Turn	Left	Thru	Right	App. Total	Peds/ Bikes	U-Turn	Left	Thru	Right	App. Total	Peds/ Bikes	U-Turn	Left	Thru	Right	App. Total	Peds/ Bikes		
6:00	--	5	82	--	87	--	--	7	--	10	17	--	--	2	33	3	38	--	--	3	4	2	9	--	151	--
6:15	--	8	110	1	119	--	--	13	1	8	22	--	1	--	34	5	40	--	--	5	3	3	11	--	192	--
6:30	--	12	129	2	143	--	--	15	2	25	42	--	--	1	73	10	84	--	--	7	3	4	14	--	283	--
6:45	--	12	136	1	149	--	--	21	5	20	46	--	--	1	78	13	92	--	--	9	7	10	26	--	313	--
Hour Total	--	37	457	4	498	--	--	56	8	63	127	--	1	4	218	31	254	--	--	24	17	19	60	--	939	--
Grand Total	8	1302	5852	314	7476	10	--	845	323	1284	2452	5	2	133	5501	784	6420	27	1	312	348	227	888	2	17236	44
% of App.	0.1%	17.4%	78.3%	4.2%			0.0%	34.5%	13.2%	52.4%			0.0%	2.1%	85.7%	12.2%			0.1%	35.1%	39.2%	25.6%				
% of Total	0.0%	7.6%	34.0%	1.8%	43.4%	22.7%	0.0%	4.9%	1.9%	7.4%	14.2%	11.4%	0.0%	0.8%	31.9%	4.5%	37.2%	61.4%	0.0%	1.8%	2.0%	1.3%	5.2%	4.5%		
Cars Total	8	1276	5465	306	7055	10	--	793	310	1258	2361	5	2	126	5155	725	6008	24	--	304	329	218	851	2	16275	41
Cars % of Movement	100%	98.0%	93.4%	97.5%	94.4%	24.4%	0.0%	93.8%	96.0%	98.0%	96.3%	12.2%	100%	94.7%	93.7%	92.5%	93.6%	58.5%	0.0%	97.4%	94.5%	96.0%	95.8%	4.9%	94.4%	
Trucks Total	--	26	387	8	421	--	--	52	13	26	91	--	--	7	346	59	412	3	1	8	19	9	37	--	961	3
Trucks % of Movement	0.0%	2.0%	6.6%	2.5%	5.6%	0.0%	0.0%	6.2%	4.0%	2.0%	3.7%	0.0%	0.0%	5.3%	6.3%	7.5%	6.4%	####	100%	2.6%	5.5%	4.0%	4.2%	0.0%	5.6%	

ALLIANT ENGINEERING, INC.

733 S Marquette Ave #700, Minneapolis, MN 55402

Intersection: TH 47 & 40th Avenue
 Date: 3/19/2024
 Duration: 0600-1800

Site Code: 602
 Ref Pt: N/A
 Page No: 2 of 4

All Vehicles (Cars & Trucks) Printed

Start Time	TH 47 Southbound						40th Avenue Westbound						TH 47 Northbound						40th Avenue Eastbound						Int. Veh. Total	Int. Ped/Bike Total
	U-Turn	Left	Thru	Right	App. Total	Peds/Bikes	U-Turn	Left	Thru	Right	App. Total	Peds/Bikes	U-Turn	Left	Thru	Right	App. Total	Peds/Bikes	U-Turn	Left	Thru	Right	App. Total	Peds/Bikes		
7:30	--	27	187	5	219	--	--	38	12	37	87	2	--	1	126	21	148	1	--	8	5	6	19	--	473	3
7:45	--	39	242	3	284	--	--	43	10	38	91	--	--	2	145	11	158	--	--	11	6	10	27	--	560	--
8:00	--	18	177	1	196	--	--	25	5	29	59	--	--	3	105	13	121	--	--	4	5	4	13	--	389	--
8:15	1	24	186	8	219	--	--	23	4	18	45	--	--	1	101	10	112	--	--	9	5	1	15	--	391	--
Hour Total	1	108	792	17	918	--	--	129	31	122	282	2	--	7	477	55	539	1	--	32	21	21	74	--	1813	3
% of App.	0.1%	11.8%	86.3%	1.9%			0.0%	45.7%	11.0%	43.3%			0.0%	1.3%	88.5%	10.2%			0.0%	43.2%	28.4%	28.4%				
% of Total	0.1%	6.0%	43.7%	0.9%	50.6%	0.0%	0.0%	7.1%	1.7%	6.7%	15.6%	66.7%	0.0%	0.4%	26.3%	3.0%	29.7%	33.3%	0.0%	1.8%	1.2%	1.2%	4.1%	0.0%		
Cars Total	1	105	749	13	868	--	--	124	28	121	273	2	--	5	449	50	504	1	--	29	19	21	69	--	1714	3
Cars % of Movement	100%	97.2%	94.6%	76.5%	94.6%	0.0%	0.0%	96.1%	90.3%	99.2%	96.8%	66.7%	0.0%	71.4%	94.1%	90.9%	93.5%	33.3%	0.0%	90.6%	90.5%	100%	93.2%	0.0%	94.5%	
Trucks Total	--	3	43	4	50	--	--	5	3	1	9	--	--	2	28	5	35	--	--	3	2	--	5	--	99	--
Trucks % of Movement	0.0%	2.8%	5.4%	23.5%	5.4%	--	0.0%	3.9%	9.7%	0.8%	3.2%	--	0.0%	28.6%	5.9%	9.1%	6.5%	--	0.0%	9.4%	9.5%	0.0%	6.8%	--	5.5%	

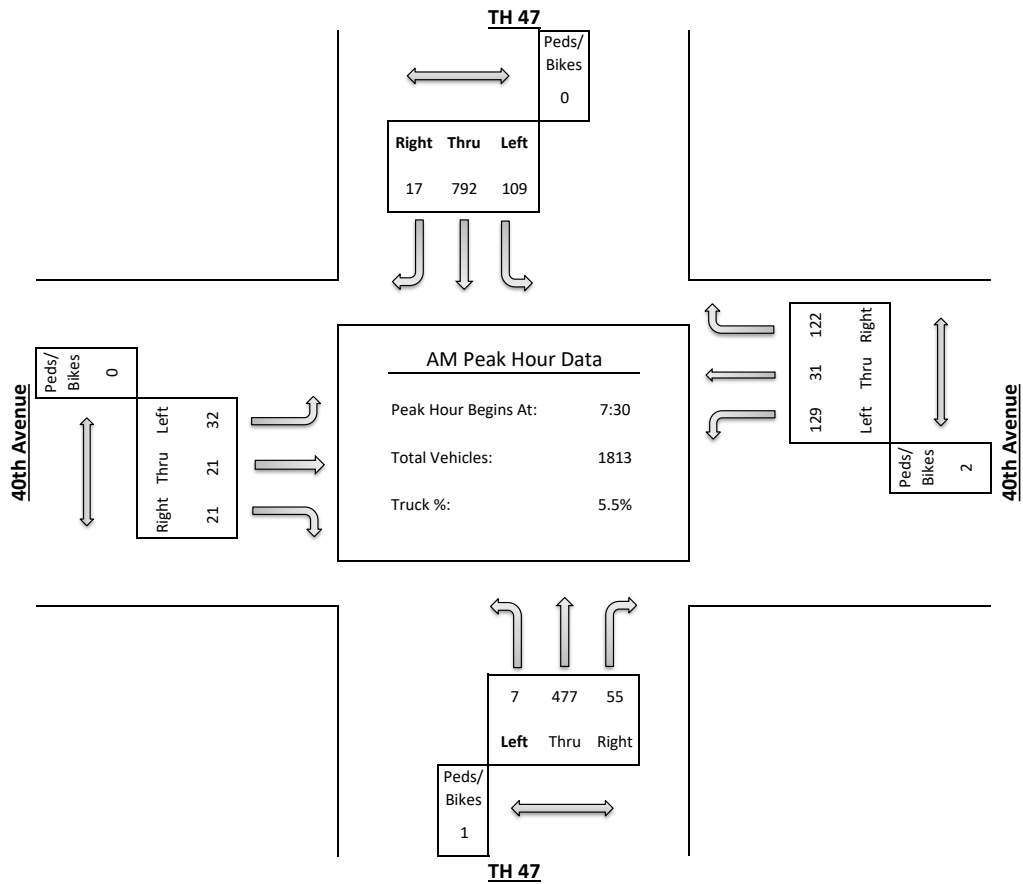

ALLIANT ENGINEERING, INC.

733 S Marquette Ave #700, Minneapolis, MN 55402

Intersection: TH 47 & 40th Avenue
 Date: 3/19/2024
 Duration: 0600-1800

Site Code: 602
 Ref Pt: N/A
 Page No: 3 of 4

All Vehicles (Cars & Trucks) Printed

Start Time	TH 47 Southbound						40th Avenue Westbound						TH 47 Northbound						40th Avenue Eastbound						Int. Veh. Total	Int. Ped/Bike Total
	U-Turn	Left	Thru	Right	App. Total	Peds/Bikes	U-Turn	Left	Thru	Right	App. Total	Peds/Bikes	U-Turn	Left	Thru	Right	App. Total	Peds/Bikes	U-Turn	Left	Thru	Right	App. Total	Peds/Bikes		
11:30	--	21	95	7	123	--	--	12	7	20	39	--	--	2	98	10	110	--	--	5	5	4	14	--	286	--
11:45	--	33	114	4	151	--	--	15	3	29	47	--	--	4	98	23	125	--	--	6	10	3	19	--	342	--
12:00	--	22	83	9	114	--	--	11	2	27	40	--	--	4	81	17	102	3	--	9	12	4	25	--	281	3
12:15	--	38	86	5	129	--	--	11	6	25	42	--	--	2	93	12	107	1	--	5	8	5	18	--	296	1
Hour Total	--	114	378	25	517	--	--	49	18	101	168	--	--	12	370	62	444	4	--	25	35	16	76	--	1205	4
% of App.	0.0%	22.1%	73.1%	4.8%			0.0%	29.2%	10.7%	60.1%			0.0%	2.7%	83.3%	14.0%			0.0%	32.9%	46.1%	21.1%				
% of Total	0.0%	9.5%	31.4%	2.1%	42.9%	0.0%	0.0%	4.1%	1.5%	8.4%	13.9%	0.0%	0.0%	1.0%	30.7%	5.1%	36.8%	#####	0.0%	2.1%	2.9%	1.3%	6.3%	0.0%		
Cars Total	--	113	330	25	468	--	--	47	18	98	163	--	--	12	351	59	422	4	--	25	35	15	75	--	1128	4
Cars % of Movement	0.0%	99.1%	87.3%	100%	90.5%	0.0%	0.0%	95.9%	100%	97.0%	97.0%	0.0%	0.0%	100%	94.9%	95.2%	95.0%	#####	0.0%	100%	100%	93.8%	98.7%	0.0%	93.6%	
Trucks Total	--	1	48	--	49	--	--	2	--	3	5	--	--	--	19	3	22	--	--	--	--	1	1	--	77	--
Trucks % of Movement	0.0%	0.9%	12.7%	0.0%	9.5%	--	0.0%	4.1%	0.0%	3.0%	3.0%	--	0.0%	0.0%	5.1%	4.8%	5.0%	--	0.0%	0.0%	0.0%	6.3%	1.3%	--	6.4%	

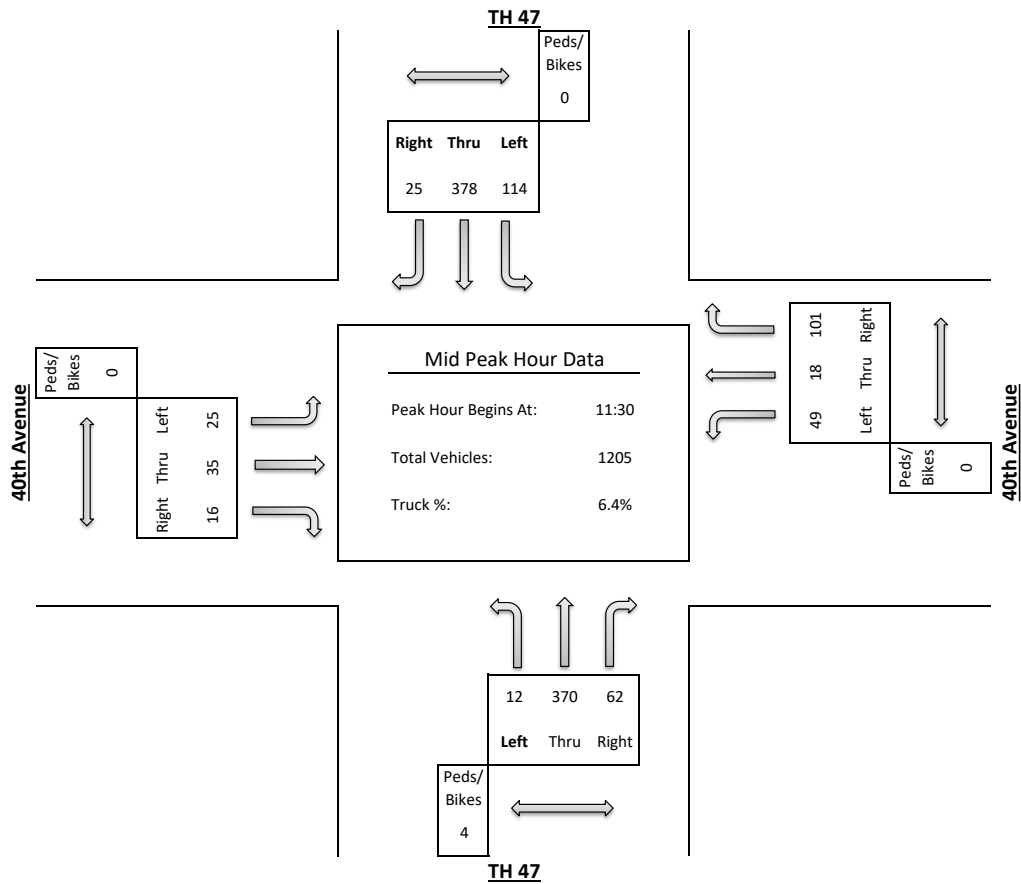

ALLIANT ENGINEERING, INC.

733 S Marquette Ave #700, Minneapolis, MN 55402

Intersection: TH 47 & 40th Avenue
 Date: 3/19/2024
 Duration: 0600-1800

Site Code: 602
 Ref Pt: N/A
 Page No: 4 of 4

All Vehicles (Cars & Trucks) Printed

Start Time	TH 47 Southbound						40th Avenue Westbound						TH 47 Northbound						40th Avenue Eastbound						Int. Veh. Total	Int. Ped/Bike Total
	U-Turn	Left	Thru	Right	App. Total	Peds/Bikes	U-Turn	Left	Thru	Right	App. Total	Peds/Bikes	U-Turn	Left	Thru	Right	App. Total	Peds/Bikes	U-Turn	Left	Thru	Right	App. Total	Peds/Bikes		
15:30	1	30	151	6	188	--	--	22	10	26	58	--	--	4	199	28	231	--	--	8	11	5	24	--	501	--
15:45	--	38	137	9	184	2	--	33	11	28	72	--	--	7	180	33	220	--	--	9	10	7	26	--	502	2
16:00	--	56	118	16	190	--	--	24	13	44	81	--	--	6	208	21	235	1	--	3	11	5	19	--	525	1
16:15	--	43	133	5	181	--	--	17	7	38	62	--	--	7	200	27	234	1	--	7	13	5	25	--	502	1
Hour Total	1	167	539	36	743	2	--	96	41	136	273	--	--	24	787	109	920	2	--	27	45	22	94	--	2030	4
% of App.	0.1%	22.5%	72.5%	4.8%			0.0%	35.2%	15.0%	49.8%			0.0%	2.6%	85.5%	11.8%			0.0%	28.7%	47.9%	23.4%				
% of Total	0.0%	8.2%	26.6%	1.8%	36.6%	50.0%	0.0%	4.7%	2.0%	6.7%	13.4%	0.0%	0.0%	1.2%	38.8%	5.4%	45.3%	50.0%	0.0%	1.3%	2.2%	1.1%	4.6%	0.0%		
Cars Total	1	165	519	36	721	2	--	90	40	134	264	--	--	23	768	103	894	1	--	26	43	21	90	--	1969	3
Cars % of Movement	100%	98.8%	96.3%	100%	97.0%	66.7%	0.0%	93.8%	97.6%	98.5%	96.7%	0.0%	0.0%	95.8%	97.6%	94.5%	97.2%	33.3%	0.0%	96.3%	95.6%	95.5%	95.7%	0.0%	97.0%	
Trucks Total	--	2	20	--	22	--	--	6	1	2	9	--	--	1	19	6	26	1	--	1	2	1	4	--	61	1
Trucks % of Movement	0.0%	1.2%	3.7%	0.0%	3.0%	0.0%	0.0%	6.3%	2.4%	1.5%	3.3%	0.0%	0.0%	4.2%	2.4%	5.5%	2.8%	#####	0.0%	3.7%	4.4%	4.5%	4.3%	0.0%	3.0%	

