



# MINNESOTA DEPT OF TRANSPORTATION

## TRAFFIC DATA COLLECTION - METRO

TH-101 at W 78th St. Chanhassen  
 Ref.Pt.:  
 Data by: Westwood Professional Services  
 TURN MOVEMENT COUNT

File Name : TH-101 at W 78th St 2008  
 Site Code : 13052530  
 Start Date : 9/30/2008  
 Page No : 1

### Groups Printed- Unshifted

Start Time	TH-101 / Chanhassen Rd. Southbound				78th St. W Westbound				TH-101 / Chanhassen Rd. Northbound				78th St. W Eastbound				Int. Total
	Left	Thru	Right	Peds	Left	Thru	Right	Peds	Left	Thru	Right	Peds	Left	Thru	Right	Peds	
06:00	1	18	8	0	0	0	0	0	1	14	7	0	21	4	5	0	79
06:15	1	20	7	0	2	0	0	0	3	26	12	0	19	3	11	0	104
06:30	2	40	28	0	0	3	0	0	3	24	18	0	28	9	9	0	164
06:45	0	44	29	0	6	3	2	0	8	37	9	0	32	12	21	1	204
Total	4	122	72	0	8	6	2	0	15	101	46	0	100	28	46	1	551
07:00	1	58	24	0	5	3	1	0	13	43	10	0	46	6	19	0	229
07:15	1	55	36	0	2	2	0	0	9	76	14	0	52	9	26	0	282
07:30	5	67	29	0	1	1	1	0	15	57	12	0	79	12	26	0	305
07:45	1	71	52	0	1	2	1	0	40	48	11	0	49	12	36	0	324
Total	8	251	141	0	9	8	3	0	77	224	47	0	226	39	107	0	1140
08:00	0	63	49	0	4	3	0	0	17	53	9	0	50	7	38	0	293
08:15	3	57	39	0	2	2	3	0	11	37	10	0	53	13	31	0	261
08:30	0	48	43	0	3	1	0	0	16	38	8	0	38	6	15	0	216
08:45	7	53	47	0	2	6	1	0	12	28	6	0	26	11	15	0	214
Total	10	221	178	0	11	12	4	0	56	156	33	0	167	37	99	0	984
*** BREAK ***																	
11:00	0	22	24	0	4	15	2	0	14	31	1	0	32	8	14	0	167
11:15	1	33	39	0	6	11	2	0	15	31	7	0	41	9	7	0	202
11:30	2	40	44	0	3	14	2	0	17	32	7	0	32	11	10	0	214
11:45	2	36	43	0	9	17	1	0	17	37	6	0	39	12	16	0	235
Total	5	131	150	0	22	57	7	0	63	131	21	0	144	40	47	0	818
12:00	1	34	41	0	6	34	3	0	24	31	6	0	41	5	18	0	244
12:15	1	30	50	0	6	9	1	0	17	34	6	0	40	15	20	0	229
12:30	2	22	37	0	3	14	2	0	27	37	9	0	36	18	12	0	219
12:45	2	47	45	0	9	11	2	0	13	30	11	0	57	15	16	0	258
Total	6	133	173	0	24	68	8	0	81	132	32	0	174	53	66	0	950
*** BREAK ***																	
15:00	1	42	67	0	7	9	3	0	36	56	3	0	58	6	7	0	295
15:15	1	48	65	0	9	8	1	0	19	48	5	0	54	8	39	0	305
15:30	0	55	67	0	7	12	4	0	18	51	4	0	68	4	25	0	315
15:45	2	37	70	0	11	10	2	0	24	47	4	0	52	7	7	0	273
Total	4	182	269	0	34	39	10	0	97	202	16	0	232	25	78	0	1188
16:00	0	35	71	0	12	10	3	0	25	46	3	0	56	13	10	0	284
16:15	0	54	72	0	5	9	5	0	33	42	2	0	71	8	12	0	313
16:30	1	41	62	0	13	8	4	0	25	68	6	0	85	13	15	0	341
16:45	4	40	88	0	8	17	2	0	29	73	2	0	66	11	8	0	348
Total	5	170	293	0	38	44	14	0	112	229	13	0	278	45	45	0	1286
17:00	1	67	84	0	16	20	4	0	31	87	1	0	77	5	19	0	412
17:15	1	68	99	0	2	20	8	0	27	64	2	0	75	9	21	0	396
17:30	2	45	89	0	3	11	7	0	21	66	3	0	73	6	16	0	342
17:45	1	83	67	0	3	6	0	0	21	54	1	0	75	5	8	0	324
Total	5	263	339	0	24	57	19	0	100	271	7	0	300	25	64	0	1474
Grand Total	47	1473	1615	0	170	291	67	0	601	1446	215	0	1621	292	552	1	8391
Apprch %	1.5	47	51.5	0	32.2	55.1	12.7	0	26.6	63.9	9.5	0	65.7	11.8	22.4	0	
Total %	0.6	17.6	19.2	0	2	3.5	0.8	0	7.2	17.2	2.6	0	19.3	3.5	6.6	0	



# MINNESOTA DEPT OF TRANSPORTATION

## TRAFFIC DATA COLLECTION - METRO

TH-101 at W 78th St. Chanhassen  
 Ref.Pt.:  
 Data by: Westwood Professional Services  
 TURN MOVEMENT COUNT

File Name : TH-101 at W 78th St 2008  
 Site Code : 13052530  
 Start Date : 9/30/2008  
 Page No : 2

Start Time	TH-101 / Chanhassen Rd. Southbound					78th St. W Westbound					TH-101 / Chanhassen Rd. Northbound					78th St. W Eastbound					Int. Total
	Left	Thru	Right	Peds	App. Total	Left	Thru	Right	Peds	App. Total	Left	Thru	Right	Peds	App. Total	Left	Thru	Right	Peds	App. Total	
Peak Hour Analysis From 06:00 to 08:45 - Peak 1 of 1																					
Peak Hour for Entire Intersection Begins at 07:15																					
07:15	1	55	36	0	92	2	2	0	0	4	9	76	14	0	99	52	9	26	0	87	282
07:30	5	67	29	0	101	1	1	1	0	3	15	57	12	0	84	79	12	26	0	117	305
07:45	1	71	52	0	124	1	2	1	0	4	40	48	11	0	99	49	12	36	0	97	324
08:00	0	63	49	0	112	4	3	0	0	7	17	53	9	0	79	50	7	38	0	95	293
Total Volume	7	256	166	0	429	8	8	2	0	18	81	234	46	0	361	230	40	126	0	396	1204
% App. Total	1.6	59.7	38.7	0		44.4	44.4	11.1	0		22.4	64.8	12.7	0		58.1	10.1	31.8	0		
PHF	.350	.901	.798	.000	.865	.500	.667	.500	.000	.643	.506	.770	.821	.000	.912	.728	.833	.829	.000	.846	.929

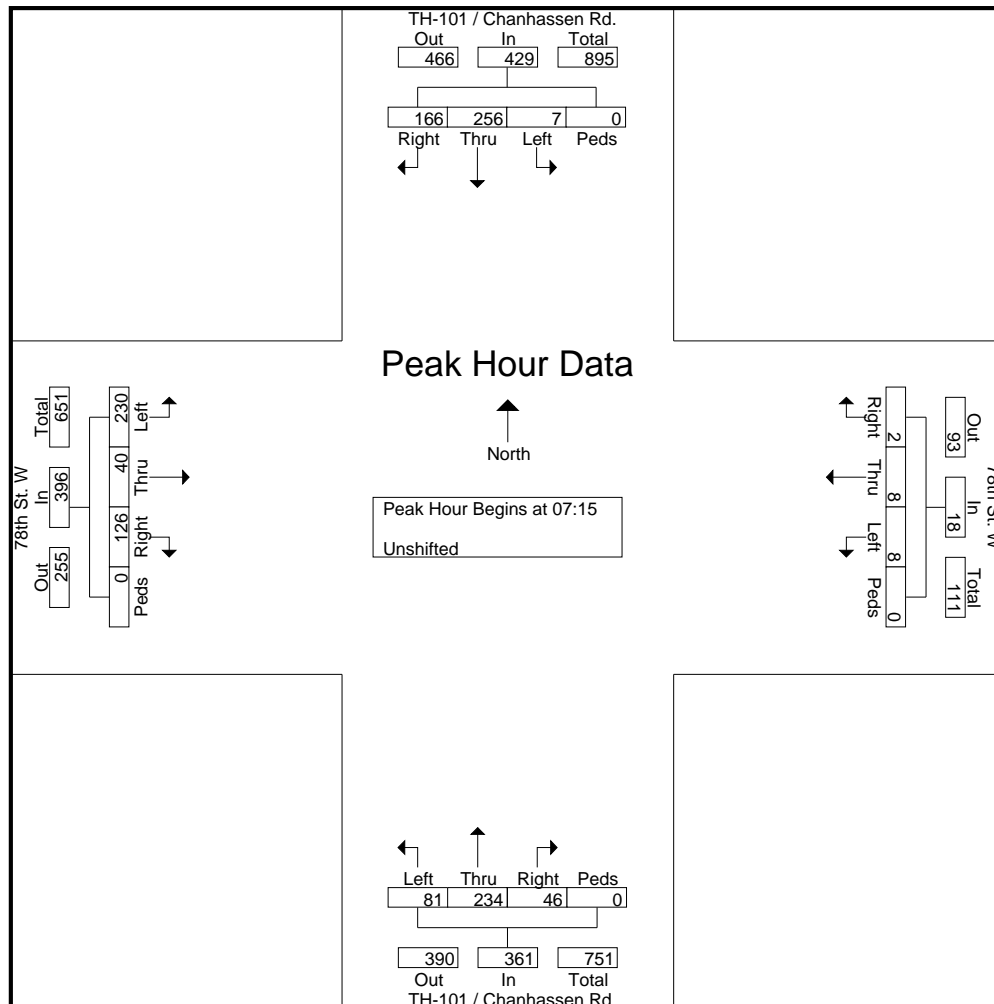



# MINNESOTA DEPT OF TRANSPORTATION

## TRAFFIC DATA COLLECTION - METRO

TH-101 at W 78th St. Chanhassen  
 Ref.Pt.:  
 Data by: Westwood Professional Services  
 TURN MOVEMENT COUNT

File Name : TH-101 at W 78th St 2008  
 Site Code : 13052530  
 Start Date : 9/30/2008  
 Page No : 3

Start Time	TH-101 / Chanhassen Rd. Southbound					78th St. W Westbound					TH-101 / Chanhassen Rd. Northbound					78th St. W Eastbound					Int. Total
	Left	Thru	Right	Peds	App. Total	Left	Thru	Right	Peds	App. Total	Left	Thru	Right	Peds	App. Total	Left	Thru	Right	Peds	App. Total	
Peak Hour Analysis From 15:00 to 17:45 - Peak 1 of 1																					
Peak Hour for Entire Intersection Begins at 16:45																					
16:45	4	40	88	0	132	8	17	2	0	27	29	73	2	0	104	66	11	8	0	85	348
17:00	1	67	84	0	152	16	20	4	0	40	31	87	1	0	119	77	5	19	0	101	412
17:15	1	68	99	0	168	2	20	8	0	30	27	64	2	0	93	75	9	21	0	105	396
17:30	2	45	89	0	136	3	11	7	0	21	21	66	3	0	90	73	6	16	0	95	342
Total Volume	8	220	360	0	588	29	68	21	0	118	108	290	8	0	406	291	31	64	0	386	1498
% App. Total	1.4	37.4	61.2	0		24.6	57.6	17.8	0		26.6	71.4	2	0		75.4	8	16.6	0		
PHF	.500	.809	.909	.000	.875	.453	.850	.656	.000	.738	.871	.833	.667	.000	.853	.945	.705	.762	.000	.919	.909

