

# Albeck Gerken, Inc

Transportation Engineers

Traffic Data Collection

Prairie Center Drive at Plaza Dr / TH-5

Ref.Pt.: 050.060 (TH-5)

Data by: Albeck Gerken Inc - Sue/Nic

TURN MOVEMENT COUNT

File Name : Prairie Center Dr at Plaza Dr TH-5 2005

Site Code : 00000000

Start Date : 1/12/2005

Page No : 1

Groups Printed- Unshifted

Start Time	PRAIRIE CENTER DRIVE Southbound				PLAZA DRIVE Westbound				PRAIRIE CENTER DRIVE Northbound				loop from/ramp to WB TH-5 Eastbound				Int. Total
	Left	Thru	Right	Peds	Left	Thru	Right	Peds	Left	Thru	Right	Peds	Left	Thru	Right	Peds	
06:30	0	59	9	0	13	8	0	0	16	35	23	0	18	7	77	0	265
06:45	2	42	4	0	11	8	3	0	23	39	30	0	23	17	81	0	283
Total	2	101	13	0	24	16	3	0	39	74	53	0	41	24	158	0	548
07:00	1	54	3	0	21	7	0	0	25	35	30	0	23	13	98	0	310
07:15	2	67	8	0	21	10	5	0	41	83	32	0	23	11	114	0	417
07:30	3	77	4	0	15	16	5	0	64	76	27	0	28	14	98	0	427
07:45	2	99	14	0	27	11	5	0	35	70	39	2	25	16	110	0	455
Total	8	297	29	0	84	44	15	0	165	264	128	2	99	54	420	0	1609
08:00	3	69	4	0	25	6	4	0	39	84	33	0	28	18	110	0	423
08:15	5	79	8	0	22	12	4	0	0	0	0	0	0	0	0	0	130
*** BREAK ***																	
Total	8	148	12	0	47	18	8	0	39	84	33	0	28	18	110	0	553
*** BREAK ***																	
16:00	5	106	34	0	34	36	10	0	106	128	37	0	31	24	88	0	639
16:15	2	124	34	0	35	32	10	0	113	122	37	0	33	28	93	0	663
16:30	2	134	41	0	25	27	14	0	139	110	30	0	31	15	100	0	668
16:45	7	115	28	0	35	37	5	0	110	132	34	0	29	15	92	0	639
Total	16	479	137	0	129	132	39	0	468	492	138	0	124	82	373	0	2609
17:00	10	128	35	0	33	29	8	0	104	136	40	0	30	24	92	0	669
17:15	8	128	34	0	42	26	13	0	137	140	46	0	22	25	127	0	748
17:30	11	128	20	0	47	22	10	0	144	138	44	0	35	26	106	0	731
17:45	8	76	29	0	38	32	16	0	100	149	31	0	27	28	135	0	669
Total	37	460	118	0	160	109	47	0	485	563	161	0	114	103	460	0	2817
Grand Total	71	1485	309	0	444	319	112	0	1196	1477	513	2	406	281	1521	0	8136
Apprch %	3.8	79.6	16.6	0	50.7	36.5	12.8	0	37.5	46.3	16.1	0.1	18.4	12.7	68.9	0	
Total %	0.9	18.3	3.8	0	5.5	3.9	1.4	0	14.7	18.2	6.3	0	5	3.5	18.7	0	

# Albeck Gerken, Inc

Transportation Engineers

Traffic Data Collection

Prairie Center Drive at Plaza Dr / TH-5  
 Ref.Pt.: 050.060 (TH-5)  
 Data by: Albeck Gerken Inc - Sue/Nic  
 TURN MOVEMENT COUNT

File Name : Prairie Center Dr at Plaza Dr TH-5 2005  
 Site Code : 00000000  
 Start Date : 1/12/2005  
 Page No : 2

Start Time	PRAIRIE CENTER DRIVE Southbound					PLAZA DRIVE Westbound					PRAIRIE CENTER DRIVE Northbound					loop from/ramp to WB TH-5 Eastbound					Int. Total
	Left	Thru	Right	Peds	App. Total	Left	Thru	Right	Peds	App. Total	Left	Thru	Right	Peds	App. Total	Left	Thru	Right	Peds	App. Total	
Peak Hour Analysis From 06:30 to 08:15 - Peak 1 of 1																					
Peak Hour for Entire Intersection Begins at 07:15																					
07:15	2	67	8	0	77	21	10	5	0	36	41	83	32	0	156	23	11	114	0	148	417
07:30	3	77	4	0	84	15	16	5	0	36	64	76	27	0	167	28	14	98	0	140	427
07:45	2	99	14	0	115	27	11	5	0	43	35	70	39	2	146	25	16	110	0	151	455
08:00	3	69	4	0	76	25	6	4	0	35	39	84	33	0	156	28	18	110	0	156	423
Total Volume	10	312	30	0	352	88	43	19	0	150	179	313	131	2	625	104	59	432	0	595	1722
% App. Total	2.8	88.6	8.5	0		58.7	28.7	12.7	0		28.6	50.1	21	0.3		17.5	9.9	72.6	0		
PHF	.833	.788	.536	.000	.765	.815	.672	.950	.000	.872	.699	.932	.840	.250	.936	.929	.819	.947	.000	.954	.946

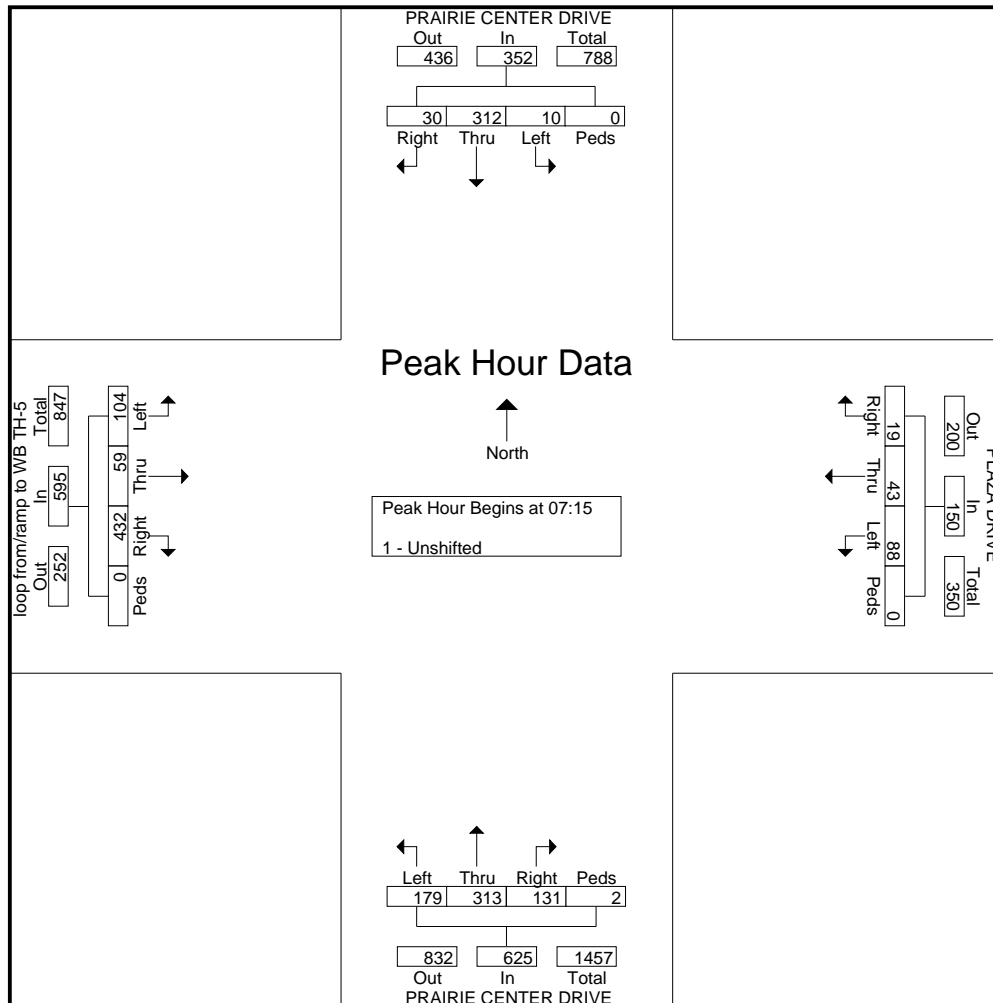

# Albeck Gerken, Inc

Transportation Engineers

Traffic Data Collection

Prairie Center Drive at Plaza Dr / TH-5  
 Ref.Pt.: 050.060 (TH-5)  
 Data by: Albeck Gerken Inc - Sue/Nic  
 TURN MOVEMENT COUNT

File Name : Prairie Center Dr at Plaza Dr TH-5 2005  
 Site Code : 00000000  
 Start Date : 1/12/2005  
 Page No : 3

Start Time	PRAIRIE CENTER DRIVE Southbound					PLAZA DRIVE Westbound					PRAIRIE CENTER DRIVE Northbound					loop from/ramp to WB TH-5 Eastbound					Int. Total
	Left	Thru	Right	Peds	App. Total	Left	Thru	Right	Peds	App. Total	Left	Thru	Right	Peds	App. Total	Left	Thru	Right	Peds	App. Total	
Peak Hour Analysis From 16:00 to 17:45 - Peak 1 of 1																					
Peak Hour for Entire Intersection Begins at 17:00																					
17:00	10	128	35	0	173	33	29	8	0	70	104	136	40	0	280	30	24	92	0	146	669
17:15	8	128	34	0	170	42	26	13	0	81	137	140	46	0	323	22	25	127	0	174	748
17:30	11	128	20	0	159	47	22	10	0	79	144	138	44	0	326	35	26	106	0	167	731
17:45	8	76	29	0	113	38	32	16	0	86	100	149	31	0	280	27	28	135	0	190	669
Total Volume	37	460	118	0	615	160	109	47	0	316	485	563	161	0	1209	114	103	460	0	677	2817
% App. Total	6	74.8	19.2	0		50.6	34.5	14.9	0		40.1	46.6	13.3	0		16.8	15.2	67.9	0		
PHF	.841	.898	.843	.000	.889	.851	.852	.734	.000	.919	.842	.945	.875	.000	.927	.814	.920	.852	.000	.891	.942

