

# MN Dept of Transportation

TRAFFIC DATA COLLECTION - Metro

TH-52 at Butler Avenue, west ramps  
 Ref.Pt.: 127.926  
 video RE  
 TURN MOVEMENT COUNT

File Name : TH-52 at Butler Ave west ramps 2014  
 Site Code :  
 Start Date : 12/14/2014  
 Page No : 1

Groups Printed- Cars +

Start Time	ramp from SB TH-52 Southbound				Butler Ave Westbound				ramp to SB TH-52 Northbound				Butler Ave Eastbound				Int. Total
	Left	Thru	Right	Peds	Left	Thru	Right	Peds	Left	Thru	Right	Peds	Left	Thru	Right	Peds	
06:00	1	0	3	0	7	14	0	0	0	0	0	0	0	27	33	0	85
06:15	2	0	15	0	8	19	0	0	0	0	0	0	0	40	25	0	109
06:30	3	0	8	0	13	17	0	0	0	0	0	0	0	64	32	0	137
06:45	4	0	16	0	10	37	0	0	0	0	0	0	0	50	40	0	157
Total	10	0	42	0	38	87	0	0	0	0	0	0	0	181	130	0	488
07:00	4	0	18	0	12	33	0	0	0	0	0	0	0	42	51	0	160
07:15	5	0	33	0	9	50	0	0	0	0	0	0	0	62	54	0	213
07:30	3	0	42	0	12	55	0	0	0	0	0	0	0	78	88	0	278
07:45	5	0	34	0	10	54	0	0	0	0	0	0	0	62	68	0	233
Total	17	0	127	0	43	192	0	0	0	0	0	0	0	244	261	0	884
08:00	5	0	27	0	17	42	0	0	0	0	0	0	0	51	41	0	183
08:15	5	0	27	0	12	62	0	0	0	0	0	0	0	41	51	0	198
08:30	2	0	26	0	4	37	0	0	0	0	0	0	0	61	46	0	176
08:45	3	0	31	0	6	35	0	0	0	0	0	0	0	44	25	0	144
Total	15	0	111	0	39	176	0	0	0	0	0	0	0	197	163	0	701
*****BREAK*****																	
15:00	7	0	48	0	3	59	0	0	0	0	0	0	0	69	50	0	236
15:15	6	0	50	0	14	72	0	0	0	0	0	0	0	68	51	0	261
15:30	15	0	58	0	6	76	0	0	0	0	0	0	0	64	47	0	266
15:45	8	0	63	0	8	55	0	0	0	0	0	0	0	70	63	0	267
Total	36	0	219	0	31	262	0	0	0	0	0	0	0	271	211	0	1030
16:00	13	1	43	0	8	61	0	0	0	0	0	0	0	60	53	0	239
16:15	16	0	55	0	6	72	0	0	0	0	0	0	0	56	51	0	256
16:30	8	0	68	0	7	69	0	0	0	0	0	0	0	54	50	0	256
16:45	8	0	56	0	3	76	0	0	0	0	0	0	0	38	44	0	225
Total	45	1	222	0	24	278	0	0	0	0	0	0	0	208	198	0	976
17:00	8	0	55	0	8	86	0	0	0	0	0	0	0	58	59	0	274
17:15	12	0	58	0	7	83	0	0	0	0	0	0	0	66	49	0	275
17:30	12	0	56	0	11	67	0	0	0	0	0	0	0	53	52	0	251
17:45	8	0	54	0	9	57	0	0	0	0	0	0	0	55	51	0	234
Total	40	0	223	0	35	293	0	0	0	0	0	0	0	232	211	0	1034
Grand Total	163	1	944	0	210	1288	0	0	0	0	0	0	0	1333	1174	0	5113
Apprch %	14.7	0.1	85.2	0	14	86	0	0	0	0	0	0	0	53.2	46.8	0	
Total %	3.2	0	18.5	0	4.1	25.2	0	0	0	0	0	0	0	26.1	23	0	

# MN Dept of Transportation

TRAFFIC DATA COLLECTION - Metro

TH-52 at Butler Avenue, west ramps  
 Ref.Pt.: 127.926  
 video RE  
 TURN MOVEMENT COUNT

File Name : TH-52 at Butler Ave west ramps 2014  
 Site Code :  
 Start Date : 12/14/2014  
 Page No : 2

Start Time	ramp from SB TH-52 Southbound					Butler Ave Westbound					ramp to SB TH-52 Northbound					Butler Ave Eastbound					Int. Total
	Left	Thru	Right	Peds	App. Total	Left	Thru	Right	Peds	App. Total	Left	Thru	Right	Peds	App. Total	Left	Thru	Right	Peds	App. Total	
Peak Hour Analysis From 06:00 to 08:45 - Peak 1 of 1																					
Peak Hour for Entire Intersection Begins at 07:15																					
07:15	5	0	33	0	38	9	50	0	0	59	0	0	0	0	0	0	62	54	0	116	213
07:30	3	0	42	0	45	12	55	0	0	67	0	0	0	0	0	0	78	88	0	166	278
07:45	5	0	34	0	39	10	54	0	0	64	0	0	0	0	0	0	62	68	0	130	233
08:00	5	0	27	0	32	17	42	0	0	59	0	0	0	0	0	0	51	41	0	92	183
Total Volume	18	0	136	0	154	48	201	0	0	249	0	0	0	0	0	0	253	251	0	504	907
% App. Total	11.7	0	88.3	0		19.3	80.7	0	0		0	0	0	0	0	0	50.2	49.8	0		
PHF	.900	.000	.810	.000	.856	.706	.914	.000	.000	.929	.000	.000	.000	.000	.000	.000	.811	.713	.000	.759	.816

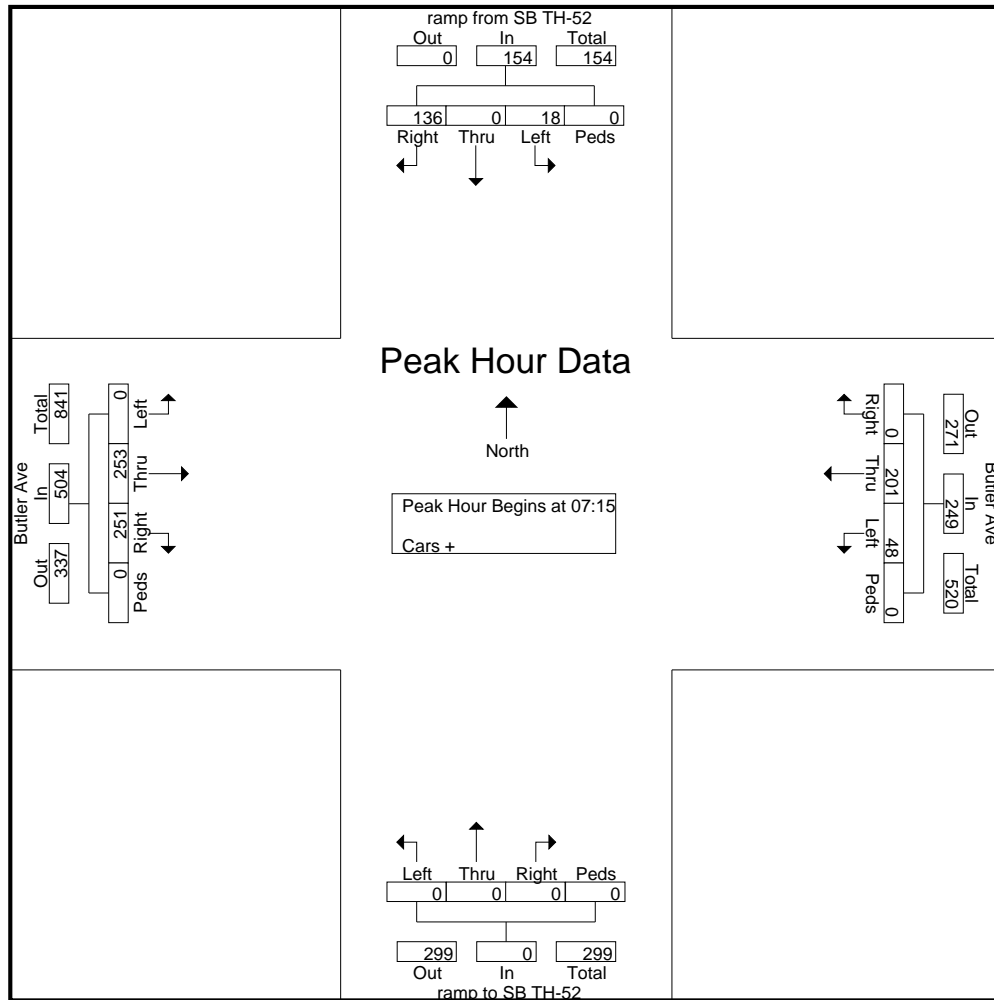

# MN Dept of Transportation

TRAFFIC DATA COLLECTION - Metro

TH-52 at Butler Avenue, west ramps  
 Ref.Pt.: 127.926  
 video RE  
 TURN MOVEMENT COUNT

File Name : TH-52 at Butler Ave west ramps 2014  
 Site Code :  
 Start Date : 12/14/2014  
 Page No : 3

Start Time	ramp from SB TH-52 Southbound					Butler Ave Westbound					ramp to SB TH-52 Northbound					Butler Ave Eastbound					Int. Total
	Left	Thru	Right	Peds	App. Total	Left	Thru	Right	Peds	App. Total	Left	Thru	Right	Peds	App. Total	Left	Thru	Right	Peds	App. Total	
Peak Hour Analysis From 15:00 to 17:45 - Peak 1 of 1																					
Peak Hour for Entire Intersection Begins at 17:00																					
17:00	8	0	55	0	63	8	86	0	0	94	0	0	0	0	0	0	58	59	0	117	274
17:15	12	0	58	0	70	7	83	0	0	90	0	0	0	0	0	0	66	49	0	115	275
17:30	12	0	56	0	68	11	67	0	0	78	0	0	0	0	0	0	53	52	0	105	251
17:45	8	0	54	0	62	9	57	0	0	66	0	0	0	0	0	0	55	51	0	106	234
Total Volume	40	0	223	0	263	35	293	0	0	328	0	0	0	0	0	0	232	211	0	443	1034
% App. Total	15.2	0	84.8	0		10.7	89.3	0	0		0	0	0	0	0	0	52.4	47.6	0		
PHF	.833	.000	.961	.000	.939	.795	.852	.000	.000	.872	.000	.000	.000	.000	.000	.000	.879	.894	.000	.947	.940

