

Alliant Engineering Inc Minneapolis, MN 55415

Vicksburg Lane at 36th Ave N
Ref.Pt.
Alliant Engineering Inc
TURN MOVEMENT COUNT

File Name : 42_Vicksburg Ln at 36th Ave_012511
Site Code : 42
Start Date : 1/25/2011
Page No : 1

Groups Printed- Unshifted - Bank 1

Start Time	Vicksburg Lane Southbound				36th Ave N Westbound				Vicksburg Lane Northbound				36th Ave N Eastbound				Int. Total
	Left	Thru	Right	Peds	Left	Thru	Right	Peds	Left	Thru	Right	Peds	Left	Thru	Right	Peds	
06:00	5	81	0	0	16	8	2	0	3	13	5	0	1	2	2	0	138
06:15	4	82	2	0	9	7	7	0	1	32	10	0	0	9	4	0	167
06:30	1	113	1	0	9	4	3	0	1	46	8	0	1	7	8	0	202
06:45	11	140	7	0	7	2	4	0	5	35	8	0	0	7	3	0	229
Total	21	416	10	0	41	21	16	0	10	126	31	0	2	25	17	0	736
07:00	12	168	2	0	20	2	4	1	7	38	17	0	0	9	6	0	286
07:15	10	181	7	1	10	5	6	0	8	42	18	0	0	41	5	1	335
07:30	15	180	3	0	12	10	8	0	5	44	16	0	1	22	10	0	326
07:45	12	99	4	0	7	3	10	0	10	45	9	0	1	15	1	0	216
Total	49	628	16	1	49	20	28	1	30	169	60	0	2	87	22	1	1163
08:00	11	126	2	0	9	7	4	0	5	33	19	0	0	10	4	0	230
08:15	6	102	4	0	6	5	5	0	4	35	20	0	1	16	6	0	210
08:30	21	116	4	0	10	14	4	0	7	40	20	0	3	25	6	0	270
08:45	9	64	1	0	11	13	6	0	0	58	33	0	0	8	3	0	206
Total	47	408	11	0	36	39	19	0	16	166	92	0	4	59	19	0	916
09:00	3	30	1	0	7	10	6	0	3	25	26	0	0	11	3	0	125
09:15	12	55	1	0	13	8	10	0	2	47	24	0	0	13	3	0	188
*** BREAK ***																	
Total	15	85	2	0	20	18	16	0	5	72	50	0	0	24	6	0	313
*** BREAK ***																	
10:30	13	43	1	1	25	9	12	0	1	36	21	0	0	6	5	0	173
10:45	16	49	0	0	29	15	12	0	0	35	20	0	2	10	4	0	192
Total	29	92	1	1	54	24	24	0	1	71	41	0	2	16	9	0	365
11:00	11	64	2	0	32	15	17	0	2	45	21	0	1	11	4	0	225
11:15	12	51	3	0	37	14	15	0	2	47	21	0	1	10	15	0	228
11:30	12	63	1	0	24	18	12	0	4	61	25	0	4	14	8	0	246
11:45	17	53	1	0	24	16	20	0	2	60	18	0	2	20	6	0	239
Total	52	231	7	0	117	63	64	0	10	213	85	0	8	55	33	0	938
12:00	9	58	4	0	32	14	27	0	3	66	32	1	1	8	8	0	263
12:15	7	57	4	3	28	22	11	0	5	54	18	2	3	7	6	1	228
12:30	7	57	4	0	29	11	18	0	3	50	26	0	3	11	6	0	225
12:45	13	64	3	0	24	16	10	0	10	60	33	0	2	10	7	0	252
Total	36	236	15	3	113	63	66	0	21	230	109	3	9	36	27	1	968
13:00	13	52	7	0	32	9	14	0	4	34	19	0	4	11	6	1	206
13:15	12	54	3	0	19	8	16	0	5	61	27	0	3	21	3	0	232
*** BREAK ***																	
Total	25	106	10	0	51	17	30	0	9	95	46	0	7	32	9	1	438
*** BREAK ***																	
14:30	9	62	2	1	27	10	14	0	1	51	20	1	2	8	7	0	215
14:45	16	47	3	0	20	14	18	0	3	75	18	0	2	15	2	0	233
Total	25	109	5	1	47	24	32	0	4	126	38	1	4	23	9	0	448
15:00	18	68	1	0	26	7	20	0	3	73	21	0	3	11	6	0	257
15:15	18	63	3	0	29	6	27	0	6	86	31	1	2	9	6	1	288
15:30	13	85	3	0	25	23	28	0	6	111	22	0	1	18	6	0	341
15:45	18	79	1	0	32	14	27	0	2	92	34	0	1	16	4	0	320
Total	67	295	8	0	112	50	102	0	17	362	108	1	7	54	22	1	1206

Alliant Engineering Inc Minneapolis, MN 55415

Vicksburg Lane at 36th Ave N
Ref.Pt.
Alliant Engineering Inc
TURN MOVEMENT COUNT

File Name : 42_Vicksburg Ln at 36th Ave_012511
Site Code : 42
Start Date : 1/25/2011
Page No : 2

Groups Printed- Unshifted - Bank 1

Start Time	Vicksburg Lane Southbound				36th Ave N Westbound				Vicksburg Lane Northbound				36th Ave N Eastbound				Int. Total
	Left	Thru	Right	Peds	Left	Thru	Right	Peds	Left	Thru	Right	Peds	Left	Thru	Right	Peds	
16:00	15	76	1	0	21	19	27	0	2	127	36	0	4	18	3	0	349
16:15	19	73	2	0	34	19	31	0	4	114	29	1	2	16	10	0	354
16:30	14	69	3	1	35	20	33	0	5	108	39	0	7	20	6	1	361
16:45	13	81	1	0	32	27	30	0	4	169	40	0	3	16	7	0	423
Total	61	299	7	1	122	85	121	0	15	518	144	1	16	70	26	1	1487
17:00	17	75	1	0	45	31	32	0	6	158	47	0	3	18	15	0	448
17:15	26	88	3	0	28	22	41	0	5	184	40	0	0	20	7	0	464
17:30	15	64	0	0	33	34	35	0	7	138	46	0	4	16	12	0	404
17:45	12	104	2	0	38	27	35	0	5	136	37	0	1	19	5	0	421
Total	70	331	6	0	144	114	143	0	23	616	170	0	8	73	39	0	1737
Grand Total	497	3236	98	7	906	538	661	1	161	2764	974	6	69	554	238	5	10715
Apprch %	12.9	84.3	2.6	0.2	43	25.5	31.4	0	4.1	70.8	24.9	0.2	8	64	27.5	0.6	
Total %	4.6	30.2	0.9	0.1	8.5	5	6.2	0	1.5	25.8	9.1	0.1	0.6	5.2	2.2	0	
Unshifted	492	3120	95	7	888	534	652	1	149	2690	958	6	64	545	229	5	10435
% Unshifted	99	96.4	96.9	100	98	99.3	98.6	100	92.5	97.3	98.4	100	92.8	98.4	96.2	100	97.4
Bank 1	5	116	3	0	18	4	9	0	12	74	16	0	5	9	9	0	280
% Bank 1	1	3.6	3.1	0	2	0.7	1.4	0	7.5	2.7	1.6	0	7.2	1.6	3.8	0	2.6

Alliant Engineering Inc Minneapolis, MN 55415

Vicksburg Lane at 36th Ave N
Ref.Pt.
Alliant Engineering Inc
TURN MOVEMENT COUNT

File Name : 42_Vicksburg Ln at 36th Ave_012511
Site Code : 42
Start Date : 1/25/2011
Page No : 3

Start Time	Vicksburg Lane Southbound					36th Ave N Westbound					Vicksburg Lane Northbound					36th Ave N Eastbound					Int. Total
	Left	Thru	Right	Peds	App. Total	Left	Thru	Right	Peds	App. Total	Left	Thru	Right	Peds	App. Total	Left	Thru	Right	Peds	App. Total	
Peak Hour Analysis From 06:00 to 09:15 - Peak 1 of 1																					
Peak Hour for Entire Intersection Begins at 06:45																					
06:45	11	140	7	0	158	7	2	4	0	13	5	35	8	0	48	0	7	3	0	10	229
07:00	12	168	2	0	182	20	2	4	1	27	7	38	17	0	62	0	9	6	0	15	286
07:15	10	181	7	1	199	10	5	6	0	21	8	42	18	0	68	0	41	5	1	47	335
07:30	15	180	3	0	198	12	10	8	0	30	5	44	16	0	65	1	22	10	0	33	326
Total Volume	48	669	19	1	737	49	19	22	1	91	25	159	59	0	243	1	79	24	1	105	1176
% App. Total	6.5	90.8	2.6	0.1		53.8	20.9	24.2	1.1		10.3	65.4	24.3	0		1	75.2	22.9	1		
PHF	.800	.924	.679	.250	.926	.613	.475	.688	.250	.758	.781	.903	.819	.000	.893	.250	.482	.600	.250	.559	.878

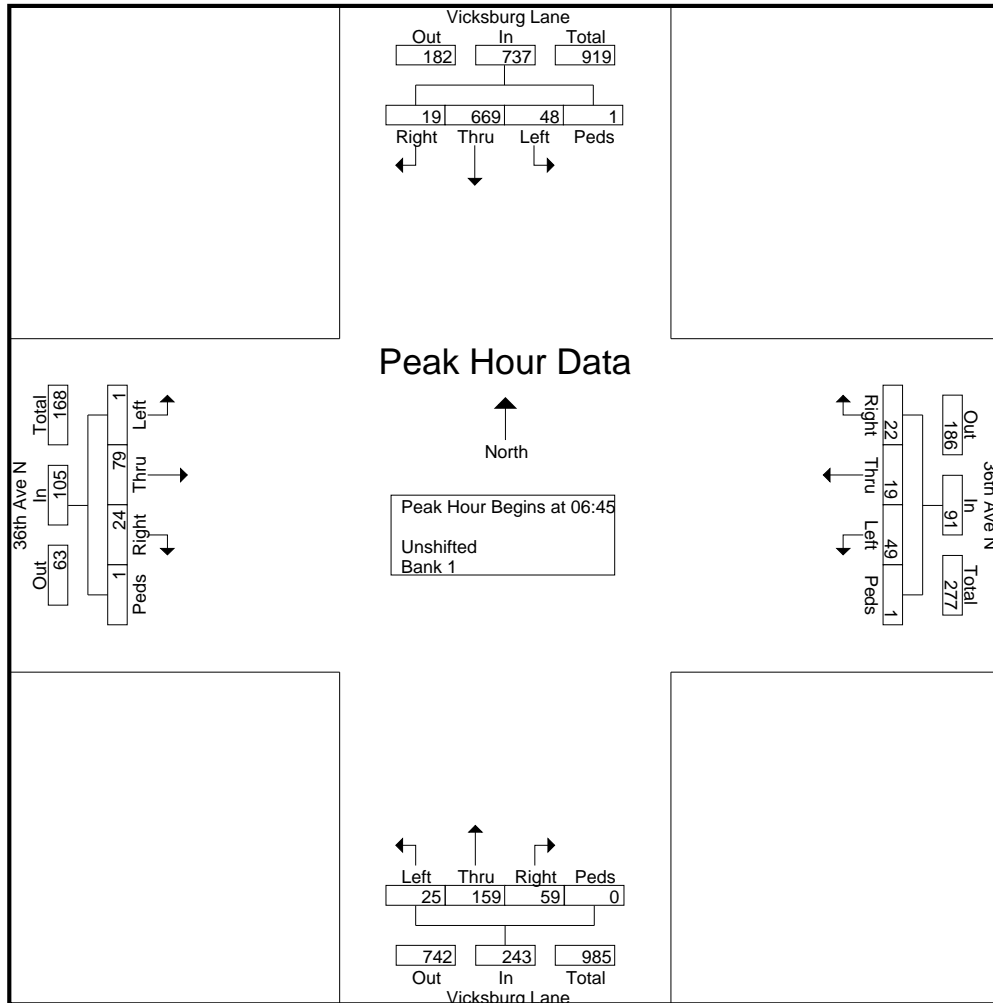

Alliant Engineering Inc Minneapolis, MN 55415

Vicksburg Lane at 36th Ave N
Ref.Pt.
Alliant Engineering Inc
TURN MOVEMENT COUNT

File Name : 42_Vicksburg Ln at 36th Ave_012511
Site Code : 42
Start Date : 1/25/2011
Page No : 4

Start Time	Vicksburg Lane Southbound					36th Ave N Westbound					Vicksburg Lane Northbound					36th Ave N Eastbound					Int. Total
	Left	Thru	Right	Peds	App. Total	Left	Thru	Right	Peds	App. Total	Left	Thru	Right	Peds	App. Total	Left	Thru	Right	Peds	App. Total	
Peak Hour Analysis From 14:30 to 17:45 - Peak 1 of 1																					
Peak Hour for Entire Intersection Begins at 16:45																					
16:45	13	81	1	0	95	32	27	30	0	89	4	169	40	0	213	3	16	7	0	26	423
17:00	17	75	1	0	93	45	31	32	0	108	6	158	47	0	211	3	18	15	0	36	448
17:15	26	88	3	0	117	28	22	41	0	91	5	184	40	0	229	0	20	7	0	27	464
17:30	15	64	0	0	79	33	34	35	0	102	7	138	46	0	191	4	16	12	0	32	404
Total Volume	71	308	5	0	384	138	114	138	0	390	22	649	173	0	844	10	70	41	0	121	1739
% App. Total	18.5	80.2	1.3	0		35.4	29.2	35.4	0		2.6	76.9	20.5	0		8.3	57.9	33.9	0		
PHF	.683	.875	.417	.000	.821	.767	.838	.841	.000	.903	.786	.882	.920	.000	.921	.625	.875	.683	.000	.840	.937

