

Alliant Engineering Inc Minneapolis, MN 55415

TH-55 at Fernbrook Lane
Ref.Pt.: 180.286
Alliant Engineering Inc
TURN MOVEMENT COUNT

File Name : 44_TH 55 at Fernbrook Ln_012511
Site Code : 00000044
Start Date : 1/25/2011
Page No : 1

Groups Printed- Unshifted - Bank 1

Start Time	TH-55 Southbound				Fernbrook Lane Westbound				TH-55 Northbound				Fernbrook Lane Eastbound				Int. Total
	Left	Thru	Right	Peds	Left	Thru	Right	Peds	Left	Thru	Right	Peds	Left	Thru	Right	Peds	
06:00	23	13	5	0	25	90	16	0	0	4	24	0	14	210	5	2	431
06:15	37	19	8	0	39	136	27	0	1	5	7	0	10	334	5	0	628
06:30	44	34	16	0	46	176	28	1	0	11	5	0	12	470	8	0	851
06:45	66	44	14	0	59	250	52	0	0	7	6	0	18	500	8	0	1024
Total	170	110	43	0	169	652	123	1	1	27	42	0	54	1514	26	2	2934
07:00	82	37	11	0	48	229	49	0	5	11	11	0	15	580	16	0	1094
07:15	76	57	10	0	41	181	58	0	0	17	7	0	13	584	9	0	1053
07:30	126	86	19	0	50	191	65	0	5	23	14	0	14	483	23	0	1099
07:45	143	110	14	0	42	256	80	0	3	13	17	0	19	636	19	0	1352
Total	427	290	54	0	181	857	252	0	13	64	49	0	61	2283	67	0	4598
08:00	110	72	12	1	52	189	61	0	5	18	22	0	25	618	23	0	1208
08:15	99	49	8	0	58	187	71	0	11	18	16	0	28	498	16	0	1059
08:30	109	47	10	0	49	216	79	0	7	15	17	0	24	426	11	0	1010
08:45	94	36	9	0	36	199	106	0	8	15	23	0	21	364	11	0	922
Total	412	204	39	1	195	791	317	0	31	66	78	0	98	1906	61	0	4199
09:00	76	20	10	0	48	196	97	0	1	14	18	0	14	317	14	0	825
09:15	77	19	11	0	35	174	66	0	8	17	23	0	18	253	9	0	710
*** BREAK ***																	
Total	153	39	21	0	83	370	163	0	9	31	41	0	32	570	23	0	1535
*** BREAK ***																	
10:30	44	15	9	0	46	179	67	0	8	11	39	0	8	200	9	1	636
10:45	63	20	14	0	28	214	49	0	4	16	25	0	19	246	15	0	713
Total	107	35	23	0	74	393	116	0	12	27	64	0	27	446	24	1	1349
11:00	58	20	13	0	36	210	56	0	9	21	45	0	13	231	22	0	734
11:15	71	25	12	0	44	213	66	0	16	34	52	0	25	277	16	0	851
11:30	68	24	19	0	40	268	82	0	14	37	61	0	30	247	26	0	916
11:45	60	38	31	0	48	260	82	0	19	42	49	0	33	259	31	1	953
Total	257	107	75	0	168	951	286	0	58	134	207	0	101	1014	95	1	3454
12:00	85	38	35	0	69	250	91	0	26	37	70	0	25	212	28	0	966
12:15	69	47	24	0	66	246	63	0	19	46	58	0	19	264	38	0	959
12:30	73	48	25	0	65	244	71	0	14	25	70	0	28	238	22	0	923
12:45	78	54	18	0	73	244	55	0	20	25	51	0	21	272	30	0	941
Total	305	187	102	0	273	984	280	0	79	133	249	0	93	986	118	0	3789
13:00	74	40	10	0	50	213	75	5	8	26	66	0	15	226	26	0	834
13:15	88	34	15	0	56	239	59	0	18	29	69	0	27	287	27	0	948
*** BREAK ***																	
Total	162	74	25	0	106	452	134	5	26	55	135	0	42	513	53	0	1782
*** BREAK ***																	
14:30	54	35	31	0	16	320	53	0	13	32	73	0	27	309	11	0	974
14:45	79	29	29	0	33	331	72	0	12	18	51	0	24	276	21	0	975
Total	133	64	60	0	49	651	125	0	25	50	124	0	51	585	32	0	1949
15:00	71	26	20	0	27	338	53	0	12	44	84	0	15	289	11	0	990
15:15	61	23	35	0	31	398	77	0	9	20	47	0	18	263	16	0	998
15:30	78	27	23	0	23	376	71	0	18	73	94	0	28	354	14	0	1179
15:45	64	24	20	0	30	445	93	0	14	43	53	0	19	254	10	0	1069
Total	274	100	98	0	111	1557	294	0	53	180	278	0	80	1160	51	0	4236

Alliant Engineering Inc Minneapolis, MN 55415

TH-55 at Fernbrook Lane
Ref.Pt.: 180.286
Alliant Engineering Inc
TURN MOVEMENT COUNT

File Name : 44_TH 55 at Fernbrook Ln_012511
Site Code : 00000044
Start Date : 1/25/2011
Page No : 2

Groups Printed- Unshifted - Bank 1

Start Time	TH-55 Southbound				Fernbrook Lane Westbound				TH-55 Northbound				Fernbrook Lane Eastbound				Int. Total
	Left	Thru	Right	Peds	Left	Thru	Right	Peds	Left	Thru	Right	Peds	Left	Thru	Right	Peds	
16:00	97	22	32	0	20	459	95	0	15	58	107	0	22	324	10	0	1261
16:15	69	29	28	0	24	494	107	0	35	71	86	0	18	317	23	1	1302
16:30	80	15	27	0	20	415	106	0	24	94	112	0	20	370	9	1	1293
16:45	78	20	25	0	9	504	126	0	26	77	66	0	23	314	9	0	1277
Total	324	86	112	0	73	1872	434	0	100	300	371	0	83	1325	51	2	5133
17:00	122	22	24	0	23	491	115	0	29	94	119	0	25	346	13	0	1423
17:15	100	31	33	0	18	514	138	0	30	68	64	0	26	298	9	0	1329
17:30	78	21	23	0	13	493	125	0	35	70	63	0	21	292	16	0	1250
17:45	58	22	29	0	23	530	133	0	10	46	41	0	21	246	13	0	1172
Total	358	96	109	0	77	2028	511	0	104	278	287	0	93	1182	51	0	5174
Grand Total	3082	1392	761	1	1559	11558	3035	6	511	1345	1925	0	815	13484	652	6	40132
Apprch %	58.9	26.6	14.5	0	9.6	71.5	18.8	0	13.5	35.6	50.9	0	5.4	90.2	4.4	0	
Total %	7.7	3.5	1.9	0	3.9	28.8	7.6	0	1.3	3.4	4.8	0	2	33.6	1.6	0	
Unshifted	3008	1355	742	1	1494	11186	2966	6	494	1290	1831	0	784	13087	624	5	38873
% Unshifted	97.6	97.3	97.5	100	95.8	96.8	97.7	100	96.7	95.9	95.1	0	96.2	97.1	95.7	83.3	96.9
Bank 1	74	37	19	0	65	372	69	0	17	55	94	0	31	397	28	1	1259
% Bank 1	2.4	2.7	2.5	0	4.2	3.2	2.3	0	3.3	4.1	4.9	0	3.8	2.9	4.3	16.7	3.1

Alliant Engineering Inc Minneapolis, MN 55415

TH-55 at Fernbrook Lane
Ref.Pt.: 180.286
Alliant Engineering Inc
TURN MOVEMENT COUNT

File Name : 44_TH 55 at Fernbrook Ln_012511
Site Code : 00000044
Start Date : 1/25/2011
Page No : 3

Start Time	TH-55 Southbound					Fernbrook Lane Westbound					TH-55 Northbound					Fernbrook Lane Eastbound					Int. Total
	Left	Thru	Right	Peds	App. Total	Left	Thru	Right	Peds	App. Total	Left	Thru	Right	Peds	App. Total	Left	Thru	Right	Peds	App. Total	
Peak Hour Analysis From 06:00 to 09:15 - Peak 1 of 1																					
Peak Hour for Entire Intersection Begins at 07:30																					
07:30	126	86	19	0	231	50	191	65	0	306	5	23	14	0	42	14	483	23	0	520	1099
07:45	143	110	14	0	267	42	256	80	0	378	3	13	17	0	33	19	636	19	0	674	1352
08:00	110	72	12	1	195	52	189	61	0	302	5	18	22	0	45	25	618	23	0	666	1208
08:15	99	49	8	0	156	58	187	71	0	316	11	18	16	0	45	28	498	16	0	542	1059
Total Volume	478	317	53	1	849	202	823	277	0	1302	24	72	69	0	165	86	2235	81	0	2402	4718
% App. Total	56.3	37.3	6.2	0.1		15.5	63.2	21.3	0		14.5	43.6	41.8	0		3.6	93	3.4	0		
PHF	.836	.720	.697	.250	.795	.871	.804	.866	.000	.861	.545	.783	.784	.000	.917	.768	.879	.880	.000	.891	.872

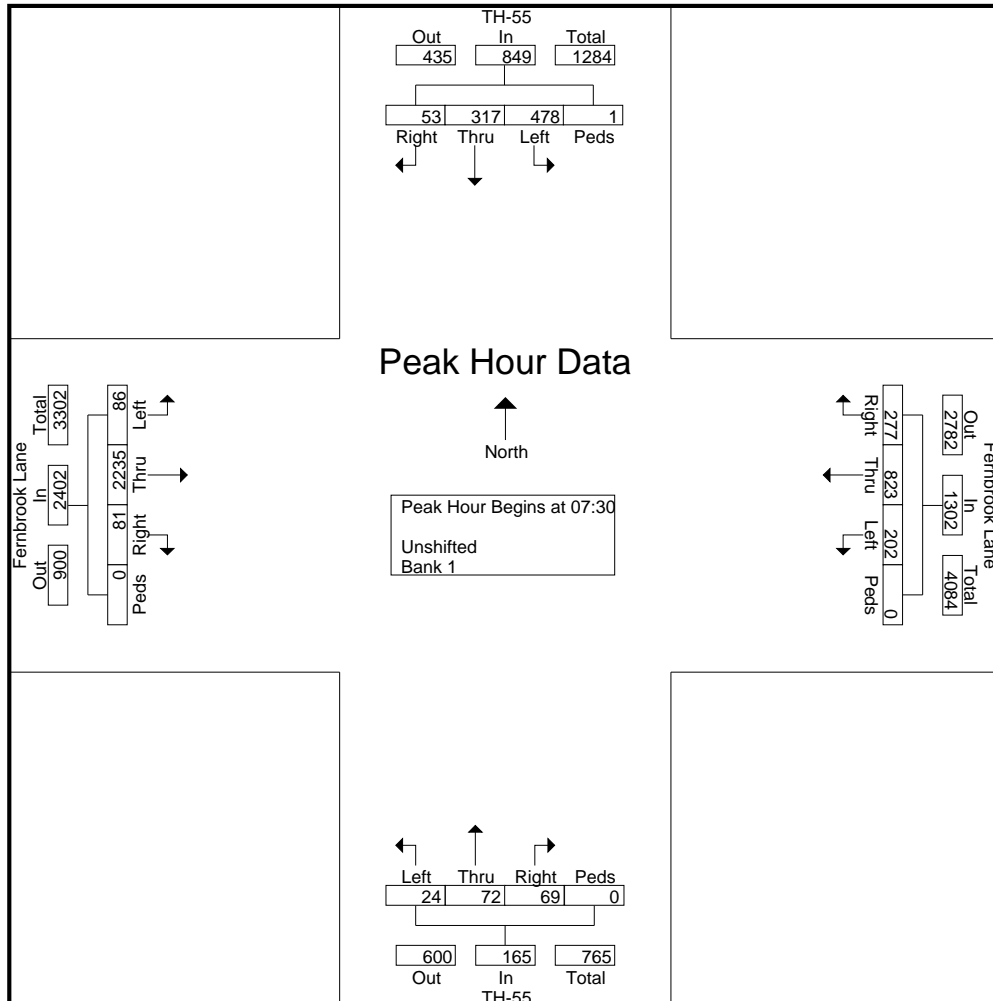

Alliant Engineering Inc Minneapolis, MN 55415

TH-55 at Fernbrook Lane
Ref.Pt.: 180.286
Alliant Engineering Inc
TURN MOVEMENT COUNT

File Name : 44_TH 55 at Fernbrook Ln_012511
Site Code : 00000044
Start Date : 1/25/2011
Page No : 4

Start Time	TH-55 Southbound					Fernbrook Lane Westbound					TH-55 Northbound					Fernbrook Lane Eastbound					Int. Total
	Left	Thru	Right	Peds	App. Total	Left	Thru	Right	Peds	App. Total	Left	Thru	Right	Peds	App. Total	Left	Thru	Right	Peds	App. Total	
Peak Hour Analysis From 14:30 to 17:45 - Peak 1 of 1																					
Peak Hour for Entire Intersection Begins at 16:30																					
16:30	80	15	27	0	122	20	415	106	0	541	24	94	112	0	230	20	370	9	1	400	1293
16:45	78	20	25	0	123	9	504	126	0	639	26	77	66	0	169	23	314	9	0	346	1277
17:00	122	22	24	0	168	23	491	115	0	629	29	94	119	0	242	25	346	13	0	384	1423
17:15	100	31	33	0	164	18	514	138	0	670	30	68	64	0	162	26	298	9	0	333	1329
Total Volume	380	88	109	0	577	70	1924	485	0	2479	109	333	361	0	803	94	1328	40	1	1463	5322
% App. Total	65.9	15.3	18.9	0		2.8	77.6	19.6	0		13.6	41.5	45	0		6.4	90.8	2.7	0.1		
PHF	.779	.710	.826	.000	.859	.761	.936	.879	.000	.925	.908	.886	.758	.000	.830	.904	.897	.769	.250	.914	.935

