

Alliant Engineering Inc Minneapolis, MN 55415

TH-7 at 12th Ave N.
Ref.Pt.: 190.796
Alliant Engineering Inc
TURN MOVEMNET COUNT

File Name : 15_TH 7 at 12th Ave_011111
Site Code : 00000015
Start Date : 1/11/2011
Page No : 1

Groups Printed- Unshifted - Bank 1

Start Time	N Service Drive connection Southbound				TH-7 Westbound				12th Ave N. Northbound				TH-7 Eastbound				Int. Total
	Left	Thru	Right	Peds	Left	Thru	Right	Peds	Left	Thru	Right	Peds	Left	Thru	Right	Peds	
06:00	4	2	0	0	1	44	4	0	1	1	8	0	0	71	0	0	136
06:15	10	2	1	0	3	47	3	0	0	0	10	0	1	116	6	0	199
06:30	16	0	1	0	2	58	7	0	2	2	8	0	3	156	3	0	258
06:45	15	0	4	0	10	95	2	0	6	1	10	0	3	192	3	0	341
Total	45	4	6	0	16	244	16	0	9	4	36	0	7	535	12	0	934
07:00	11	2	2	0	4	85	7	0	6	0	19	0	2	217	3	0	358
07:15	14	5	4	0	3	128	7	0	10	5	14	0	6	284	5	0	485
07:30	21	1	4	0	2	197	7	0	10	6	20	0	4	312	5	0	589
07:45	19	3	5	0	9	248	10	0	7	3	16	0	7	368	10	0	705
Total	65	11	15	0	18	658	31	0	33	14	69	0	19	1181	23	0	2137
08:00	25	2	5	0	20	179	8	0	3	6	9	0	7	346	9	0	619
08:15	27	11	4	0	9	174	6	0	8	3	14	0	5	358	5	0	624
08:30	27	10	2	0	6	184	13	0	8	10	8	0	19	327	10	0	624
08:45	48	15	7	0	7	190	9	0	8	16	12	0	27	269	12	0	620
Total	127	38	18	0	42	727	36	0	27	35	43	0	58	1300	36	0	2487
09:00	38	15	5	0	7	150	8	0	11	4	8	0	18	260	8	0	532
09:15	34	13	9	0	6	180	8	0	6	8	7	0	5	218	16	0	510
*** BREAK ***																	
Total	72	28	14	0	13	330	16	0	17	12	15	0	23	478	24	0	1042
*** BREAK ***																	
10:30	15	5	5	0	4	104	5	0	5	3	7	0	6	132	8	0	299
10:45	11	2	2	0	8	138	6	0	5	4	8	0	1	165	5	0	355
Total	26	7	7	0	12	242	11	0	10	7	15	0	7	297	13	0	654
11:00	19	5	2	0	5	143	8	0	9	3	4	0	2	129	7	0	336
11:15	11	9	3	0	9	119	15	0	8	2	7	0	1	147	7	0	338
11:30	12	9	1	0	9	131	3	0	6	5	6	0	2	132	10	0	326
11:45	5	5	1	0	13	140	3	0	12	4	7	0	1	153	8	0	352
Total	47	28	7	0	36	533	29	0	35	14	24	0	6	561	32	0	1352
12:00	27	11	7	0	10	145	5	0	5	5	4	0	2	157	7	0	385
12:15	11	7	6	0	12	131	8	0	5	8	8	0	4	176	12	0	388
12:30	15	7	6	0	10	154	8	0	9	7	13	0	3	124	3	0	359
12:45	11	3	5	0	6	169	10	0	9	5	10	0	4	154	14	0	400
Total	64	28	24	0	38	599	31	0	28	25	35	0	13	611	36	0	1532
13:00	11	5	2	0	3	162	3	0	12	1	4	0	0	142	2	0	347
13:15	16	4	2	0	3	151	10	0	8	6	9	0	1	155	6	0	371
*** BREAK ***																	
Total	27	9	4	0	6	313	13	0	20	7	13	0	1	297	8	0	718
*** BREAK ***																	
14:30	5	3	3	0	10	180	15	0	7	3	13	0	3	128	9	0	379
14:45	13	2	9	0	9	201	24	0	10	8	6	0	1	165	15	0	463
Total	18	5	12	0	19	381	39	0	17	11	19	0	4	293	24	0	842
15:00	19	5	8	0	18	192	15	0	13	5	9	0	7	158	16	1	466
15:15	24	4	8	0	18	232	20	0	13	10	16	0	6	156	7	0	514
15:30	47	13	12	0	9	257	12	0	8	8	15	0	10	153	12	0	556
15:45	25	10	4	0	14	279	13	0	12	9	10	0	4	189	10	1	580
Total	115	32	32	0	59	960	60	0	46	32	50	0	27	656	45	2	2116

Alliant Engineering Inc Minneapolis, MN 55415

TH-7 at 12th Ave N.
Ref.Pt.: 190.796
Alliant Engineering Inc
TURN MOVEMNET COUNT

File Name : 15_TH 7 at 12th Ave_011111
Site Code : 00000015
Start Date : 1/11/2011
Page No : 2

Groups Printed- Unshifted - Bank 1

Start Time	N Service Drive connection Southbound				TH-7 Westbound				12th Ave N. Northbound				TH-7 Eastbound				Int. Total
	Left	Thru	Right	Peds	Left	Thru	Right	Peds	Left	Thru	Right	Peds	Left	Thru	Right	Peds	
16:00	20	8	9	0	20	283	11	1	15	6	14	0	4	169	17	0	577
16:15	10	8	5	0	22	312	3	0	18	7	18	0	0	207	11	0	621
16:30	23	5	8	0	14	275	9	0	15	9	14	0	1	196	8	0	577
16:45	24	4	14	0	24	349	11	1	15	5	17	1	3	250	16	0	734
Total	77	25	36	0	80	1219	34	2	63	27	63	1	8	822	52	0	2509
17:00	23	9	9	0	13	344	10	0	17	5	10	0	3	234	15	0	692
17:15	22	5	5	0	17	381	20	1	26	11	11	0	9	287	13	0	808
17:30	18	7	7	0	18	314	26	0	13	11	11	0	3	257	19	0	704
17:45	28	5	9	0	13	331	18	3	20	5	12	0	6	236	24	1	711
Total	91	26	30	0	61	1370	74	4	76	32	44	0	21	1014	71	1	2915
Grand Total	774	241	205	0	400	7576	390	6	381	220	426	1	194	8045	376	3	19238
Apprch %	63.4	19.8	16.8	0	4.8	90.5	4.7	0.1	37.1	21.4	41.4	0.1	2.3	93.4	4.4	0	
Total %	4	1.3	1.1	0	2.1	39.4	2	0	2	1.1	2.2	0	1	41.8	2	0	
Unshifted	735	221	198	0	393	7423	380	6	373	200	419	1	181	7913	367	3	18813
% Unshifted	95	91.7	96.6	0	98.2	98	97.4	100	97.9	90.9	98.4	100	93.3	98.4	97.6	100	97.8
Bank 1	39	20	7	0	7	153	10	0	8	20	7	0	13	132	9	0	425
% Bank 1	5	8.3	3.4	0	1.8	2	2.6	0	2.1	9.1	1.6	0	6.7	1.6	2.4	0	2.2

Alliant Engineering Inc Minneapolis, MN 55415

TH-7 at 12th Ave N.
Ref.Pt.: 190.796
Alliant Engineering Inc
TURN MOVEMNET COUNT

File Name : 15_TH 7 at 12th Ave_011111
Site Code : 00000015
Start Date : 1/11/2011
Page No : 3

Start Time	N Service Drive connection Southbound					TH-7 Westbound					12th Ave N. Northbound					TH-7 Eastbound					Int. Total
	Left	Thru	Right	Peds	App. Total	Left	Thru	Right	Peds	App. Total	Left	Thru	Right	Peds	App. Total	Left	Thru	Right	Peds	App. Total	
Peak Hour Analysis From 06:00 to 09:15 - Peak 1 of 1																					
Peak Hour for Entire Intersection Begins at 07:45																					
07:45	19	3	5	0	27	9	248	10	0	267	7	3	16	0	26	7	368	10	0	385	705
08:00	25	2	5	0	32	20	179	8	0	207	3	6	9	0	18	7	346	9	0	362	619
08:15	27	11	4	0	42	9	174	6	0	189	8	3	14	0	25	5	358	5	0	368	624
08:30	27	10	2	0	39	6	184	13	0	203	8	10	8	0	26	19	327	10	0	356	624
Total Volume	98	26	16	0	140	44	785	37	0	866	26	22	47	0	95	38	1399	34	0	1471	2572
% App. Total	70	18.6	11.4	0		5.1	90.6	4.3	0		27.4	23.2	49.5	0		2.6	95.1	2.3	0		
PHF	.907	.591	.800	.000	.833	.550	.791	.712	.000	.811	.813	.550	.734	.000	.913	.500	.950	.850	.000	.955	.912

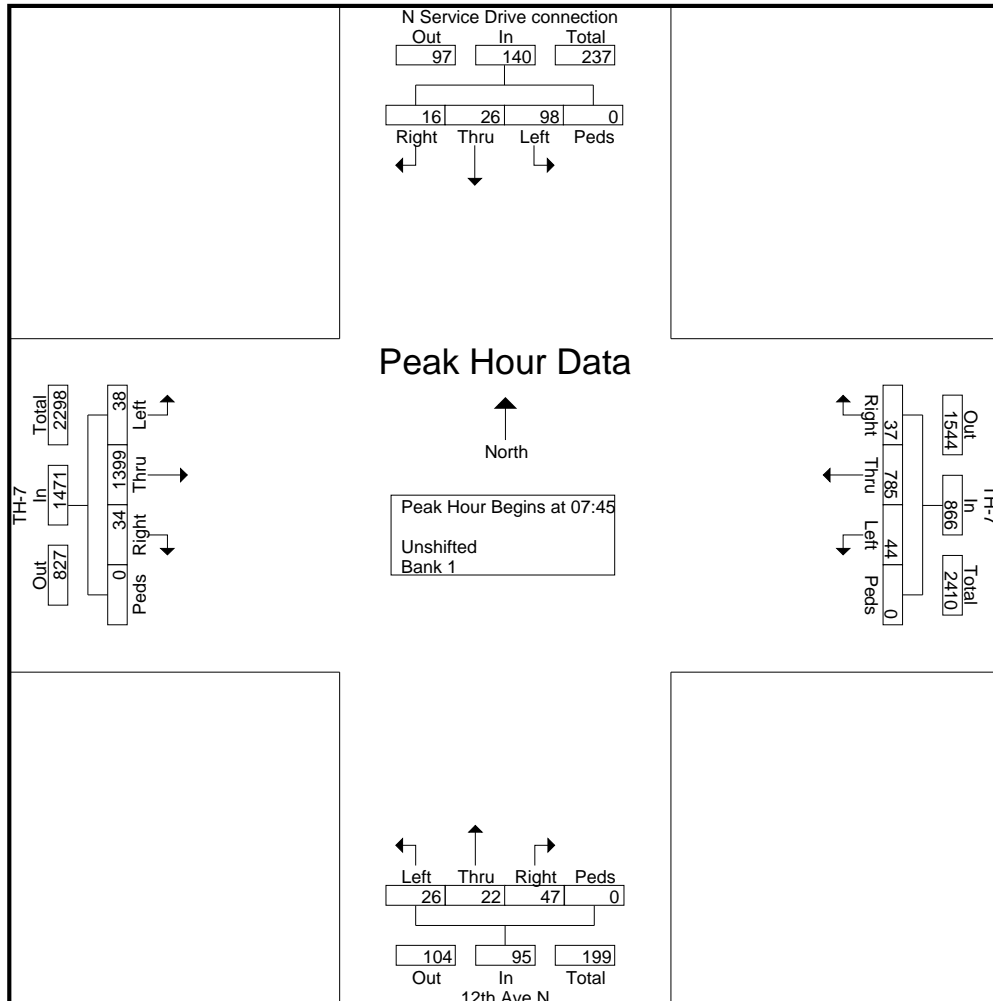

Alliant Engineering Inc Minneapolis, MN 55415

TH-7 at 12th Ave N.
Ref.Pt.: 190.796
Alliant Engineering Inc
TURN MOVEMNET COUNT

File Name : 15_TH 7 at 12th Ave_011111
Site Code : 00000015
Start Date : 1/11/2011
Page No : 4

Start Time	N Service Drive connection Southbound					TH-7 Westbound					12th Ave N. Northbound					TH-7 Eastbound					Int. Total
	Left	Thru	Right	Peds	App. Total	Left	Thru	Right	Peds	App. Total	Left	Thru	Right	Peds	App. Total	Left	Thru	Right	Peds	App. Total	
Peak Hour Analysis From 14:30 to 17:45 - Peak 1 of 1																					
Peak Hour for Entire Intersection Begins at 16:45																					
16:45	24	4	14	0	42	24	349	11	1	385	15	5	17	1	38	3	250	16	0	269	734
17:00	23	9	9	0	41	13	344	10	0	367	17	5	10	0	32	3	234	15	0	252	692
17:15	22	5	5	0	32	17	381	20	1	419	26	11	11	0	48	9	287	13	0	309	808
17:30	18	7	7	0	32	18	314	26	0	358	13	11	11	0	35	3	257	19	0	279	704
Total Volume	87	25	35	0	147	72	1388	67	2	1529	71	32	49	1	153	18	1028	63	0	1109	2938
% App. Total	59.2	17	23.8	0		4.7	90.8	4.4	0.1		46.4	20.9	32	0.7		1.6	92.7	5.7	0		
PHF	.906	.694	.625	.000	.875	.750	.911	.644	.500	.912	.683	.727	.721	.250	.797	.500	.895	.829	.000	.897	.909

