

TRAFFIC DATA INC.

3268 Xenwood Ave S
St Louis Park, MN 55416

TH-8 at CSAH-20 / N Lakes Trl / Oak St
Ref.Pt.: 011.752
TDI Inc
TURN MOVEMENT COUNT

File Name : 26811114 Hwy 8 & CR 20
Site Code : 26811114
Start Date : 2/23/2011
Page No : 1

Groups Printed- Class 1

Start Time	CSAH-20 / N Lakes Trail Southbound				TH-8 Westbound				Oak St. Northbound				TH-8 Eastbound				Int. Total
	Left	Thru	Right	Peds	Left	Thru	Right	Peds	Left	Thru	Right	Peds	Left	Thru	Right	Peds	
06:00	9	0	13	0	1	133	2	0	9	1	0	0	3	38	1	0	210
06:15	8	2	9	0	0	119	1	0	12	0	1	0	2	50	0	0	204
06:30	14	0	14	0	0	121	2	0	17	2	1	0	1	73	2	0	247
06:45	22	2	14	0	0	142	3	0	21	6	2	0	0	88	1	0	301
Total	53	4	50	0	1	515	8	0	59	9	4	0	6	249	4	0	962
07:00	25	1	14	0	1	135	5	1	33	8	5	1	2	133	5	0	369
07:15	36	1	18	0	1	139	6	0	42	7	1	0	0	140	2	0	393
07:30	22	2	14	0	0	130	4	0	42	9	3	0	3	131	2	0	362
07:45	25	1	13	0	0	104	5	0	27	8	1	0	2	137	1	0	324
Total	108	5	59	0	2	508	20	1	144	32	10	1	7	541	10	0	1448
08:00	17	0	13	0	0	97	5	0	22	6	1	0	4	90	2	0	257
08:15	19	1	16	0	1	99	10	0	21	4	0	0	4	98	1	0	274
08:30	12	4	13	0	0	96	7	1	24	4	2	1	2	78	2	0	246
08:45	18	4	10	0	2	97	11	0	24	6	3	0	3	107	2	0	287
Total	66	9	52	0	3	389	33	1	91	20	6	1	13	373	7	0	1064
09:00	10	4	5	1	1	98	13	0	20	5	1	0	4	95	3	0	260
09:15	13	2	4	0	1	100	7	0	16	6	0	0	3	69	2	0	223
09:30	10	3	6	0	0	107	5	0	21	3	1	1	3	74	1	0	235
09:45	9	3	6	0	1	94	12	1	14	4	2	1	3	74	4	0	228
Total	42	12	21	1	3	399	37	1	71	18	4	2	13	312	10	0	946
10:00	16	2	6	0	2	82	7	0	14	7	2	0	5	95	1	0	239
10:15	19	1	6	0	2	82	6	1	19	9	2	0	5	81	2	0	235
10:30	16	0	7	0	4	97	8	0	18	4	2	0	7	98	5	0	266
10:45	17	2	7	0	1	94	8	0	13	1	2	0	6	95	0	0	246
Total	68	5	26	0	9	355	29	1	64	21	8	0	23	369	8	0	986
11:00	12	2	10	0	2	87	8	0	26	13	5	0	8	97	2	0	272
11:15	15	3	8	1	1	96	6	0	17	5	1	0	4	102	3	0	262
11:30	14	1	13	0	0	109	7	0	30	13	5	0	6	105	6	0	309
11:45	8	0	7	0	0	96	3	0	20	5	0	0	3	101	2	0	245
Total	49	6	38	1	3	388	24	0	93	36	11	0	21	405	13	0	1088
12:00	15	4	8	0	1	87	5	0	28	8	2	0	5	100	5	0	268
12:15	16	1	11	0	3	99	9	0	28	8	4	0	3	92	4	0	278
12:30	16	3	7	0	2	81	9	0	23	4	1	1	3	104	6	1	261
12:45	18	1	14	0	1	71	14	0	26	8	3	0	4	110	3	0	273
Total	65	9	40	0	7	338	37	0	105	28	10	1	15	406	18	1	1080
13:00	15	5	5	0	2	76	7	0	16	8	2	0	5	110	3	0	254
13:15	15	4	6	0	1	97	9	0	17	10	3	0	8	126	3	0	299
13:30	23	2	8	1	2	90	9	0	16	12	3	0	11	96	5	0	278
13:45	25	0	9	1	2	107	9	0	22	11	2	0	5	111	0	0	304
Total	78	11	28	2	7	370	34	0	71	41	10	0	29	443	11	0	1135
14:00	13	4	3	0	2	81	4	0	27	9	6	0	7	140	10	0	306
14:15	19	0	3	0	1	84	7	0	43	14	3	0	7	123	2	0	306
14:30	12	2	5	0	3	109	7	0	69	28	5	0	6	123	6	0	375
14:45	12	3	8	0	2	97	8	0	30	18	2	0	9	124	1	0	314
Total	56	9	19	0	8	371	26	0	169	69	16	0	29	510	19	0	1301
15:00	18	0	14	0	4	112	12	0	47	15	1	0	8	147	5	0	383
15:15	19	2	5	0	3	107	9	0	25	8	2	0	11	138	4	0	333
15:30	30	3	9	0	5	102	11	0	38	9	5	0	15	165	4	0	396

TRAFFIC DATA INC.

3268 Xenwood Ave S
St Louis Park, MN 55416

TH-8 at CSAH-20 / N Lakes Trl / Oak St
Ref.Pt.: 011.752
TDI Inc
TURN MOVEMENT COUNT

File Name : 26811114 Hwy 8 & CR 20
Site Code : 26811114
Start Date : 2/23/2011
Page No : 2

Groups Printed- Class 1

Start Time	CSAH-20 / N Lakes Trail Southbound				TH-8 Westbound				Oak St. Northbound				TH-8 Eastbound				Int. Total
	Left	Thru	Rght	Peds	Left	Thru	Rght	Peds	Left	Thru	Rght	Peds	Left	Thru	Rght	Peds	
15:45	27	7	2	0	4	111	12	0	35	11	3	0	11	180	3	0	406
Total	94	12	30	0	16	432	44	0	145	43	11	0	45	630	16	0	1518
16:00	17	11	10	0	2	120	11	0	37	14	4	0	10	184	5	0	425
16:15	29	9	4	0	4	100	7	0	32	15	3	0	11	177	5	0	396
16:30	25	5	5	0	4	143	7	0	48	20	5	0	14	205	5	0	486
16:45	23	4	10	0	6	139	11	0	37	16	4	0	15	212	2	0	479
Total	94	29	29	0	16	502	36	0	154	65	16	0	50	778	17	0	1786
17:00	30	6	11	0	5	96	11	0	35	19	5	4	15	186	2	0	425
17:15	27	14	9	0	8	114	9	0	40	18	6	2	11	208	4	0	470
17:30	16	3	13	0	4	110	3	0	60	14	4	1	12	184	3	0	427
17:45	13	3	15	0	2	96	2	0	28	9	6	0	10	164	4	0	352
Total	86	26	48	0	19	416	25	0	163	60	21	7	48	742	13	0	1674
18:00	29	4	3	0	4	82	8	0	31	15	4	0	9	173	7	0	369
18:15	26	5	5	0	2	80	2	0	20	12	3	0	8	172	6	0	341
18:30	17	1	5	2	4	61	2	0	31	10	6	1	7	163	7	0	317
18:45	27	8	3	1	6	81	5	0	26	10	6	0	8	151	6	0	338
Total	99	18	16	3	16	304	17	0	108	47	19	1	32	659	26	0	1365
Grand Total	958	155	456	7	110	5287	370	4	1437	489	146	13	331	6417	172	1	16353
Apprch %	60.8	9.8	28.9	0.4	1.9	91.6	6.4	0.1	68.9	23.5	7	0.6	4.8	92.7	2.5	0	
Total %	5.9	0.9	2.8	0	0.7	32.3	2.3	0	8.8	3	0.9	0.1	2	39.2	1.1	0	

TRAFFIC DATA INC.

3268 Xenwood Ave S
St Louis Park, MN 55416

TH-8 at CSAH-20 / N Lakes Trl / Oak St
Ref.Pt.: 011.752
TDI Inc
TURN MOVEMENT COUNT

File Name : 26811114 Hwy 8 & CR 20
Site Code : 26811114
Start Date : 2/23/2011
Page No : 3

Start Time	CSAH-20 / N Lakes Trail Southbound					TH-8 Westbound					Oak St. Northbound					TH-8 Eastbound					Int. Total
	Left	Thru	Right	Peds	App. Total	Left	Thru	Right	Peds	App. Total	Left	Thru	Right	Peds	App. Total	Left	Thru	Right	Peds	App. Total	
Peak Hour Analysis From 06:00 to 09:30 - Peak 1 of 1																					
Peak Hour for Entire Intersection Begins at 07:00																					
07:00	25	1	14	0	40	1	135	5	1	142	33	8	5	1	47	2	133	5	0	140	369
07:15	36	1	18	0	55	1	139	6	0	146	42	7	1	0	50	0	140	2	0	142	393
07:30	22	2	14	0	38	0	130	4	0	134	42	9	3	0	54	3	131	2	0	136	362
07:45	25	1	13	0	39	0	104	5	0	109	27	8	1	0	36	2	137	1	0	140	324
Total Volume	108	5	59	0	172	2	508	20	1	531	144	32	10	1	187	7	541	10	0	558	1448
% App. Total	62.8	2.9	34.3	0		0.4	95.7	3.8	0.2		77	17.1	5.3	0.5		1.3	97	1.8	0		
PHF	.750	.625	.819	.000	.782	.500	.914	.833	.250	.909	.857	.889	.500	.250	.866	.583	.966	.500	.000	.982	.921

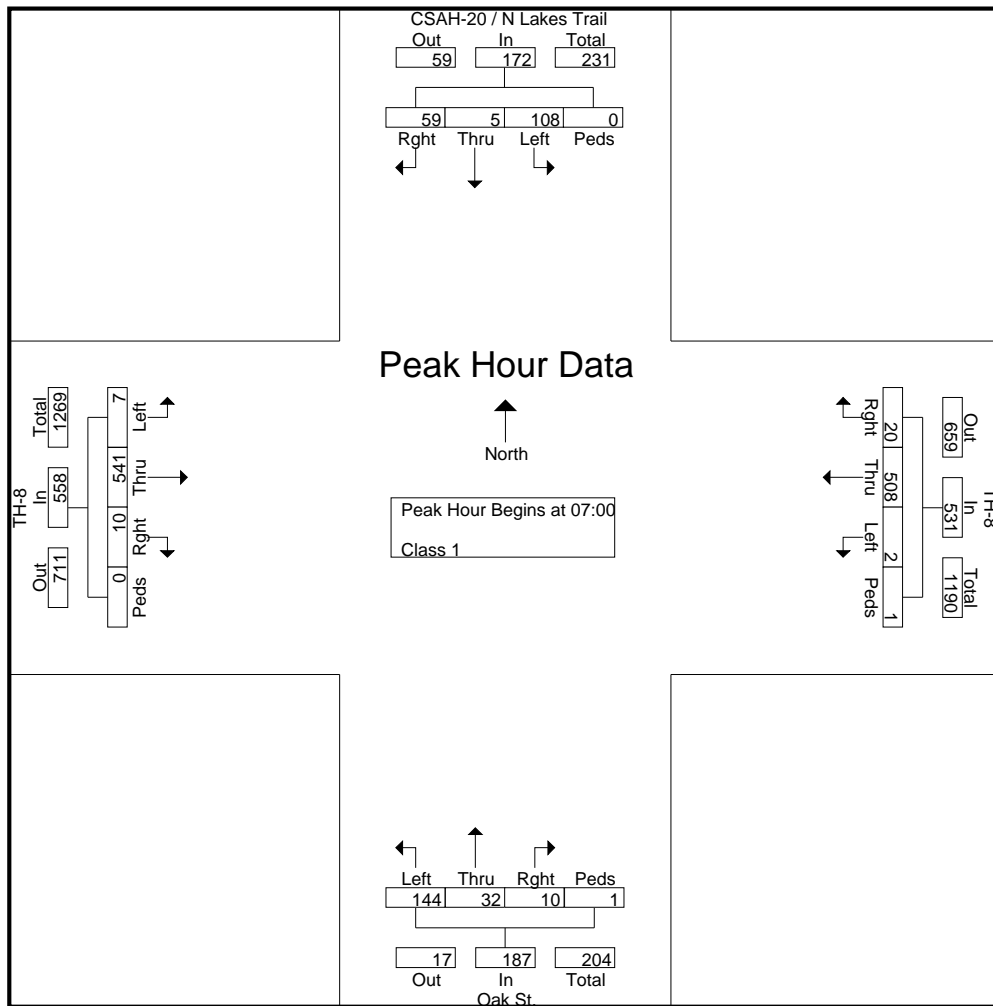

TRAFFIC DATA INC.

3268 Xenwood Ave S
St Louis Park, MN 55416

TH-8 at CSAH-20 / N Lakes Trl / Oak St
Ref.Pt.: 011.752
TDI Inc
TURN MOVEMENT COUNT

File Name : 26811114 Hwy 8 & CR 20
Site Code : 26811114
Start Date : 2/23/2011
Page No : 4

Start Time	CSAH-20 / N Lakes Trail Southbound					TH-8 Westbound					Oak St. Northbound					TH-8 Eastbound					Int. Total
	Left	Thru	Rght	Peds	App. Total	Left	Thru	Rght	Peds	App. Total	Left	Thru	Rght	Peds	App. Total	Left	Thru	Rght	Peds	App. Total	
Peak Hour Analysis From 14:30 to 18:45 - Peak 1 of 1																					
Peak Hour for Entire Intersection Begins at 16:30																					
16:30	25	5	5	0	35	4	143	7	0	154	48	20	5	0	73	14	205	5	0	224	486
16:45	23	4	10	0	37	6	139	11	0	156	37	16	4	0	57	15	212	2	0	229	479
17:00	30	6	11	0	47	5	96	11	0	112	35	19	5	4	63	15	186	2	0	203	425
17:15	27	14	9	0	50	8	114	9	0	131	40	18	6	2	66	11	208	4	0	223	470
Total Volume	105	29	35	0	169	23	492	38	0	553	160	73	20	6	259	55	811	13	0	879	1860
% App. Total	62.1	17.2	20.7	0		4.2	89	6.9	0		61.8	28.2	7.7	2.3		6.3	92.3	1.5	0		
PHF	.875	.518	.795	.000	.845	.719	.860	.864	.000	.886	.833	.913	.833	.375	.887	.917	.956	.650	.000	.960	.957

