

Alliant Engineering, Inc

233 Park Ave Suite 300

Minneapolis, MN 55415

--TRAFFIC DATA --

TH-95 at Chestnut Street

Ref.Pt.: 22.544

data by : Alliant Inc.

TURN MOVEMENT COUNT

File Name : 322_TH 95 & Chestnut St

Site Code : 322

Start Date : 11/14/2017

Page No : 1

Groups Printed- Vehicles - Trucks

Start Time	TH 95 From North				Chestnut St From East				TH 95 From South				Chestnut St From West				Int. Total
	Other	Left	Thru	Rght	Other	Left	Thru	Rght	Other	Left	Thru	Rght	Other	Left	Thru	Rght	
05:00 AM	0	0	10	0	0	0	0	0	0	0	2	0	0	0	0	2	14
05:15 AM	0	0	22	0	0	0	0	1	0	0	10	2	0	0	0	5	40
05:30 AM	0	0	35	0	0	0	0	0	0	0	13	0	0	0	0	10	58
05:45 AM	0	0	42	0	0	0	0	0	0	0	13	1	0	4	0	5	65
Total	0	0	109	0	0	0	0	1	0	0	38	3	0	4	0	22	177
06:00 AM	0	0	30	1	0	2	0	0	0	0	14	1	0	1	0	6	55
06:15 AM	0	2	35	1	0	0	0	0	0	1	31	0	0	1	2	4	77
06:30 AM	0	0	50	3	0	0	0	1	0	0	44	0	0	0	0	4	102
06:45 AM	0	1	51	5	0	0	0	1	0	0	37	0	0	1	1	3	100
Total	0	3	166	10	0	2	0	2	0	1	126	1	0	3	3	17	334
07:00 AM	0	1	52	8	0	0	0	0	0	0	53	0	0	2	0	8	124
07:15 AM	0	1	47	10	0	1	0	0	0	0	46	0	0	2	1	6	114
07:30 AM	0	4	82	9	0	3	1	0	0	1	83	1	0	5	2	7	198
07:45 AM	0	2	44	7	0	0	0	0	0	0	65	3	0	1	0	8	130
Total	0	8	225	34	0	4	1	0	0	1	247	4	0	10	3	29	566
08:00 AM	0	3	56	9	0	0	0	0	0	0	63	1	0	1	1	10	144
08:15 AM	0	2	57	6	0	2	1	0	0	0	52	3	0	2	1	10	136
08:30 AM	0	2	50	4	0	0	0	0	0	0	59	2	0	2	3	6	128
08:45 AM	0	2	54	12	0	1	0	2	0	0	64	11	0	4	1	6	157
Total	0	9	217	31	0	3	1	2	0	0	238	17	0	9	6	32	565
09:00 AM	0	3	61	10	0	3	1	1	0	2	40	3	0	3	1	12	140
09:15 AM	0	2	64	7	0	0	0	4	0	0	66	1	0	1	2	4	151
09:30 AM	1	4	40	4	0	2	0	3	0	0	57	4	0	6	3	7	131
09:45 AM	0	3	44	6	0	1	1	0	0	1	39	0	0	1	2	3	101
Total	1	12	209	27	0	6	2	8	0	3	202	8	0	11	8	26	523
10:00 AM	0	2	48	1	0	4	0	2	0	1	39	1	0	3	2	6	109
10:15 AM	0	2	44	4	0	1	0	3	0	0	47	2	0	2	1	5	111
10:30 AM	0	2	48	5	0	2	0	1	0	1	52	2	0	1	0	5	119
10:45 AM	0	1	43	7	0	4	1	2	0	0	46	3	0	5	5	4	121
Total	0	7	183	17	0	11	1	8	0	2	184	8	0	11	8	20	460
11:00 AM	0	4	66	2	0	4	1	0	0	1	57	3	0	4	0	11	153
11:15 AM	0	3	54	5	0	3	1	3	0	1	48	2	0	5	2	7	134
11:30 AM	1	4	56	4	0	2	1	2	0	0	43	7	0	2	4	10	136
11:45 AM	0	0	53	3	0	1	1	0	0	0	59	2	0	0	2	14	135
Total	1	11	229	14	0	10	4	5	0	2	207	14	0	11	8	42	558
12:00 PM	0	1	56	3	0	1	0	2	0	1	52	8	0	2	3	5	134
12:15 PM	0	1	56	4	0	6	2	0	0	0	43	4	0	4	3	15	138
12:30 PM	0	0	52	6	0	3	2	3	0	2	53	3	0	6	1	7	138
12:45 PM	0	1	54	9	0	4	3	0	0	1	68	3	0	6	2	10	161
Total	0	3	218	22	0	14	7	5	0	4	216	18	0	18	9	37	571
01:00 PM	0	3	53	5	0	2	5	1	0	0	53	4	0	5	3	7	141
01:15 PM	0	2	47	3	0	4	1	2	0	1	55	0	0	3	0	5	123
01:30 PM	0	1	46	7	0	3	2	2	0	0	43	1	0	2	1	11	119
01:45 PM	0	4	48	3	0	4	1	0	0	0	56	5	0	7	2	7	137
Total	0	10	194	18	0	13	9	5	0	1	207	10	0	17	6	30	520
02:00 PM	0	2	54	3	0	3	1	1	0	1	51	4	0	4	2	9	135
02:15 PM	0	1	61	3	0	2	3	0	0	0	65	2	0	6	2	9	154
02:30 PM	0	4	47	2	0	2	2	3	0	1	59	2	0	6	2	7	137
02:45 PM	0	0	39	4	0	8	1	0	0	0	89	3	0	1	3	8	156
Total	0	7	201	12	0	15	7	4	0	2	264	11	0	17	9	33	582

Alliant Engineering, Inc

233 Park Ave Suite 300

Minneapolis, MN 55415

--TRAFFIC DATA --

TH-95 at Chestnut Street
 Ref.Pt.: 22.544
 data by : Alliant Inc.
 TURN MOVEMENT COUNT

File Name : 322_TH 95 & Chestnut St
 Site Code : 322
 Start Date : 11/14/2017
 Page No : 2

Groups Printed- Vehicles - Trucks

Start Time	TH 95 From North				Chestnut St From East				TH 95 From South				Chestnut St From West				Int. Total
	Other	Left	Thru	Rght	Other	Left	Thru	Rght	Other	Left	Thru	Rght	Other	Left	Thru	Rght	
03:00 PM	0	0	53	2	0	1	0	3	0	0	53	3	0	3	2	6	126
03:15 PM	0	2	56	5	0	1	2	0	0	0	78	5	0	1	2	4	156
03:30 PM	0	0	56	4	0	6	2	1	0	0	84	8	0	5	2	8	176
03:45 PM	0	0	61	9	0	7	4	2	0	1	78	5	0	5	0	17	189
Total	0	2	226	20	0	15	8	6	0	1	293	21	0	14	6	35	647
04:00 PM	0	1	47	6	0	4	1	3	0	0	77	5	0	5	3	8	160
04:15 PM	0	3	88	4	0	6	0	4	0	2	60	11	0	4	4	13	199
04:30 PM	0	5	59	5	0	10	2	2	0	3	69	2	0	2	1	15	175
04:45 PM	0	1	76	4	0	4	5	2	0	0	66	1	0	7	2	22	190
Total	0	10	270	19	0	24	8	11	0	5	272	19	0	18	10	58	724
05:00 PM	0	3	95	6	0	3	4	4	0	0	84	1	0	6	0	18	224
05:15 PM	0	3	71	8	0	5	1	1	0	0	72	10	0	2	4	15	192
05:30 PM	0	2	63	7	0	4	4	4	0	2	63	8	0	2	2	7	168
05:45 PM	0	3	60	9	0	8	2	6	0	1	68	9	0	3	6	6	181
Total	0	11	289	30	0	20	11	15	0	3	287	28	0	13	12	46	765
06:00 PM	0	3	45	5	0	10	4	4	0	1	45	5	0	2	0	9	133
06:15 PM	0	1	36	5	0	5	4	0	0	0	36	5	0	0	2	3	97
06:30 PM	0	1	42	2	0	2	4	1	0	1	43	7	0	6	6	7	122
06:45 PM	0	1	46	2	0	6	4	2	0	1	76	3	0	4	2	1	148
Total	0	6	169	14	0	23	16	7	0	3	200	20	0	12	10	20	500
07:00 PM	0	1	30	4	0	2	2	3	0	1	48	2	0	2	0	4	99
07:15 PM	0	1	26	2	0	2	3	4	0	0	46	3	0	4	3	6	100
07:30 PM	0	0	25	3	0	6	0	1	0	1	30	1	0	2	4	2	75
07:45 PM	0	0	14	6	0	5	2	3	0	1	30	3	0	1	2	7	74
Total	0	2	95	15	0	15	7	11	0	3	154	9	0	9	9	19	348
08:00 PM	0	1	33	1	0	3	3	0	0	0	37	4	0	3	2	4	91
08:15 PM	0	0	16	2	0	8	1	3	0	0	29	1	0	3	0	6	69
08:30 PM	0	0	25	2	0	3	1	4	0	0	23	1	0	1	0	7	67
08:45 PM	0	0	26	2	0	4	0	2	0	1	18	1	0	1	1	5	61
Total	0	1	100	7	0	18	5	9	0	1	107	7	0	8	3	22	288
09:00 PM	0	0	21	2	0	0	1	3	0	0	21	0	0	3	0	4	55
09:15 PM	0	1	13	1	0	1	1	2	0	0	28	0	0	1	0	2	50
09:30 PM	0	0	16	1	0	1	1	1	0	0	18	4	0	1	0	3	46
09:45 PM	0	0	14	2	0	2	0	1	0	0	8	0	0	0	0	3	30
Total	0	1	64	6	0	4	3	7	0	0	75	4	0	5	0	12	181
Grand Total	2	103	3164	296	0	197	90	106	0	32	3317	202	0	190	110	500	8309
Apprch %	0.1	2.9	88.8	8.3	0	50.1	22.9	27	0	0.9	93.4	5.7	0	23.8	13.8	62.5	
Total %	0	1.2	38.1	3.6	0	2.4	1.1	1.3	0	0.4	39.9	2.4	0	2.3	1.3	6	
Vehicles	2	103	2935	295	0	192	85	103	0	31	3083	198	0	179	102	477	7785
% Vehicles	100	100	92.8	99.7	0	97.5	94.4	97.2	0	96.9	92.9	98	0	94.2	92.7	95.4	93.7
Trucks	0	0	229	1	0	5	5	3	0	1	234	4	0	11	8	23	524
% Trucks	0	0	7.2	0.3	0	2.5	5.6	2.8	0	3.1	7.1	2	0	5.8	7.3	4.6	6.3

Alliant Engineering, Inc

233 Park Ave Suite 300
 Minneapolis, MN 55415
 --TRAFFIC DATA --

TH-95 at Chestnut Street
 Ref.Pt.: 22.544
 data by : Alliant Inc.
 TURN MOVEMENT COUNT

File Name : 322_TH 95 & Chestnut St
 Site Code : 322
 Start Date : 11/14/2017
 Page No : 3

Start Time	TH 95 From North					Chestnut St From East					TH 95 From South					Chestnut St From West					Int. Total
	Other	Left	Thru	Rght	App. Total	Other	Left	Thru	Rght	App. Total	Other	Left	Thru	Rght	App. Total	Other	Left	Thru	Rght	App. Total	
Peak Hour Analysis From 05:00 AM to 11:45 AM - Peak 1 of 1																					
Peak Hour for Entire Intersection Begins at 07:30 AM																					
07:30 AM	0	4	82	9	95	0	3	1	0	4	0	1	83	1	85	0	5	2	7	14	198
07:45 AM	0	2	44	7	53	0	0	0	0	0	0	0	65	3	68	0	1	0	8	9	130
08:00 AM	0	3	56	9	68	0	0	0	0	0	0	0	63	1	64	0	1	1	10	12	144
08:15 AM	0	2	57	6	65	0	2	1	0	3	0	0	52	3	55	0	2	1	10	13	136
Total Volume	0	11	239	31	281	0	5	2	0	7	0	1	263	8	272	0	9	4	35	48	608
% App. Total	0	3.9	85.1	11		0	71.4	28.6	0		0	0.4	96.7	2.9		0	18.8	8.3	72.9		
PHF	.000	.688	.729	.861	.739	.000	.417	.500	.000	.438	.000	.250	.792	.667	.800	.000	.450	.500	.875	.857	.768

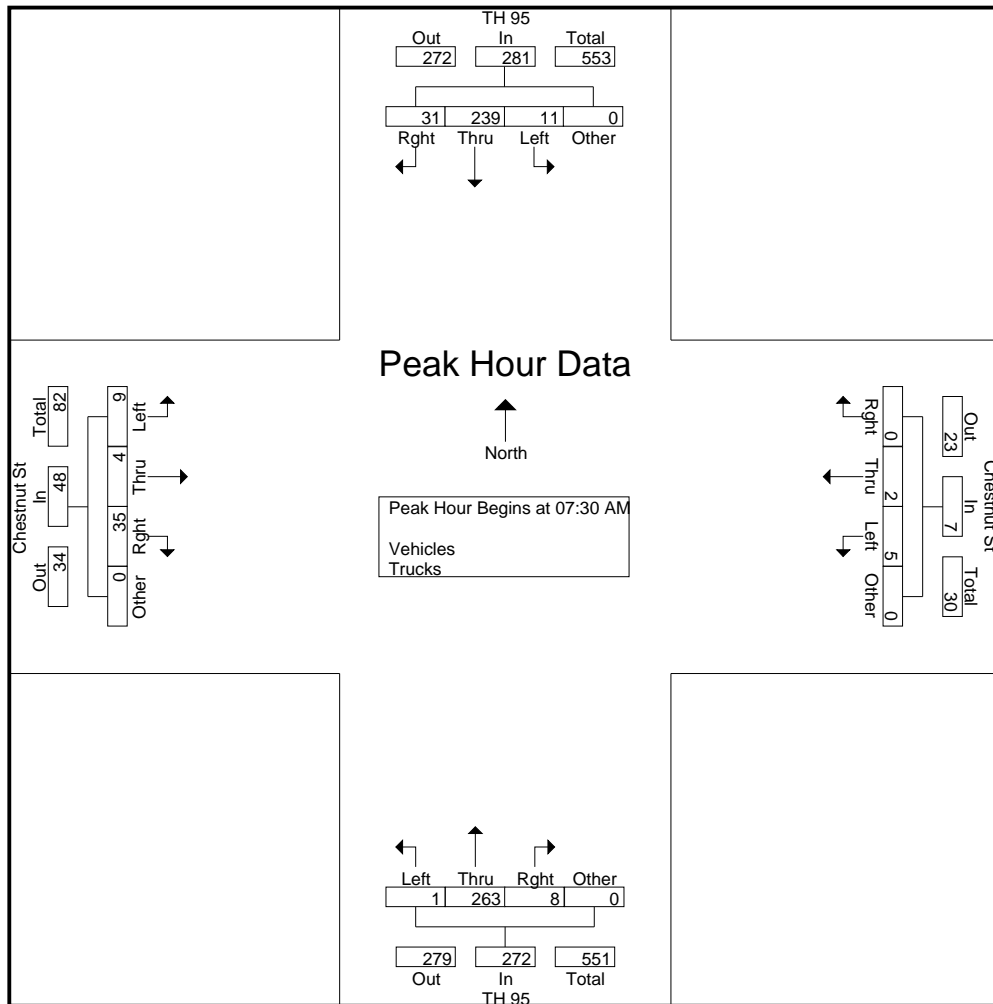

Alliant Engineering, Inc

233 Park Ave Suite 300
 Minneapolis, MN 55415
 --TRAFFIC DATA --

TH-95 at Chestnut Street
 Ref.Pt.: 22.544
 data by : Alliant Inc.
 TURN MOVEMENT COUNT

File Name : 322_TH 95 & Chestnut St
 Site Code : 322
 Start Date : 11/14/2017
 Page No : 4

Start Time	TH 95 From North					Chestnut St From East					TH 95 From South					Chestnut St From West					Int. Total
	Other	Left	Thru	Rght	App. Total	Other	Left	Thru	Rght	App. Total	Other	Left	Thru	Rght	App. Total	Other	Left	Thru	Rght	App. Total	
Peak Hour Analysis From 12:00 PM to 09:45 PM - Peak 1 of 1																					
Peak Hour for Entire Intersection Begins at 04:15 PM																					
04:15 PM	0	3	88	4	95	0	6	0	4	10	0	2	60	11	73	0	4	4	13	21	199
04:30 PM	0	5	59	5	69	0	10	2	2	14	0	3	69	2	74	0	2	1	15	18	175
04:45 PM	0	1	76	4	81	0	4	5	2	11	0	0	66	1	67	0	7	2	22	31	190
05:00 PM	0	3	95	6	104	0	3	4	4	11	0	0	84	1	85	0	6	0	18	24	224
Total Volume	0	12	318	19	349	0	23	11	12	46	0	5	279	15	299	0	19	7	68	94	788
% App. Total	0	3.4	91.1	5.4		0	50	23.9	26.1		0	1.7	93.3	5		0	20.2	7.4	72.3		
PHF	.000	.600	.837	.792	.839	.000	.575	.550	.750	.821	.000	.417	.830	.341	.879	.000	.679	.438	.773	.758	.879

